



**SPC BENCHMARK 1™
FULL DISCLOSURE REPORT**

**HUAWEI TECHNOLOGIES CO., LTD.
HUAWEI OCEANSTOR™ 5500 V3**

SPC-1 V1.14

**Submitted for Review: April 26, 2016
Submission Identifier: A00174**

First Edition – April 2016

THE INFORMATION CONTAINED IN THIS DOCUMENT IS DISTRIBUTED ON AN AS IS BASIS WITHOUT ANY WARRANTY EITHER EXPRESS OR IMPLIED. The use of this information or the implementation of any of these techniques is the customer's responsibility and depends on the customer's ability to evaluate and integrate them into the customer's operational environment. While each item has been reviewed by Huawei Technologies Co., Ltd. for accuracy in a specific situation, there is no guarantee that the same or similar results will be obtained elsewhere. Customers attempting to adapt these techniques to their own environment do so at their own risk.

This publication was produced in the United States. Huawei Technologies Co., Ltd. may not offer the products, services, or features discussed in this document in other countries, and the information is subject to change with notice. Consult your local Huawei Technologies Co., Ltd. representative for information on products and services available in your area.

© Copyright Huawei Technologies Co., Ltd. 2016. All rights reserved.

Permission is hereby granted to reproduce this document in whole or in part, provided the copyright notice as printed above is set forth in full text on the title page of each item reproduced.

Trademarks

SPC Benchmark-1, SPC-1, SPC-1 IOPS, SPC-1 LRT and SPC-1 Price-Performance are trademarks of the Storage Performance Council. Huawei, the Huawei logo and OceanStor are trademarks or registered trademarks of Huawei Technologies Co., Ltd. in the United States and other countries. All other brands, trademarks, and product names are the property of their respective owners.

Table of Contents

Audit Certification	vii
Audit Certification (cont.)	viii
Letter of Good Faith	ix
Executive Summary	10
Test Sponsor and Contact Information	10
Revision Information and Key Dates	10
Tested Storage Product (TSP) Description	11
Summary of Results	12
Storage Capacities, Relationships, and Utilization	13
Response Time – Throughput Curve	16
Response Time – Throughput Data	16
Priced Storage Configuration Pricing	17
Differences between the Tested Storage Configuration (TSC) and Priced Storage Configuration	18
Priced Storage Configuration Diagram	19
Priced Storage Configuration Components	20
Configuration Information	21
Benchmark Configuration (BC)/Tested Storage Configuration (TSC) Diagram	21
Storage Network Configuration	21
Host System(s) and Tested Storage Configuration (TSC) Table of Components	21
Benchmark Configuration/Tested Storage Configuration Diagram	22
Host System and Tested Storage Configuration Components	23
Benchmark Configuration/Tested Storage Configuration Connections	24
Host System, FC HBA, Engine, Controller, FC Host Port Module/Ports	24
Host System to Controller Host Port FC Connections	24
Engine, Controller, Eth/FCoE Module/Active Port Relationships	25
Controller-to-Controller Eth/FCoE Connections	26
Controller to Controller Eth/FCoE Connections (<i>continued</i>).....	27
Customer Tunable Parameters and Options	28
Tested Storage Configuration (TSC) Description	28
SPC-1 Workload Generator Storage Configuration	28
ASU Pre-Fill	29
SPC-1 Data Repository	30
Storage Capacities and Relationships	30
SPC-1 Storage Capacities	30
SPC-1 Storage Hierarchy Ratios	31

SPC-1 Storage Capacity Charts	31
Storage Capacity Utilization	33
Logical Volume Capacity and ASU Mapping.....	34
SPC-1 Benchmark Execution Results.....	35
SPC-1 Tests, Test Phases, and Test Runs.....	35
“Ramp-Up” Test Runs.....	36
Primary Metrics Test – Sustainability Test Phase	36
SPC-1 Workload Generator Input Parameters	37
Sustainability Test Results File	37
Sustainability – Data Rate Distribution Data (MB/second)	37
Sustainability – Data Rate Distribution Graph	37
Sustainability – I/O Request Throughput Distribution Data	38
Sustainability – I/O Request Throughput Distribution Graph	38
Sustainability – Average Response Time (ms) Distribution Data	39
Sustainability – Average Response Time (ms) Distribution Graph	39
Sustainability – Response Time Frequency Distribution Data	40
Sustainability – Response Time Frequency Distribution Graph	40
Sustainability – Measured Intensity Multiplier and Coefficient of Variation.....	41
Primary Metrics Test – IOPS Test Phase.....	42
SPC-1 Workload Generator Input Parameters	42
IOPS Test Results File.....	42
IOPS Test Run – I/O Request Throughput Distribution Data	43
IOPS Test Run – I/O Request Throughput Distribution Graph.....	43
IOPS Test Run – Average Response Time (ms) Distribution Data	44
IOPS Test Run – Average Response Time (ms) Distribution Graph	44
IOPS Test Run –Response Time Frequency Distribution Data	45
IOPS Test Run –Response Time Frequency Distribution Graph.....	45
IOPS Test Run – I/O Request Information.....	46
IOPS Test Run – Measured Intensity Multiplier and Coefficient of Variation	46
Primary Metrics Test – Response Time Ramp Test Phase	47
SPC-1 Workload Generator Input Parameters	47
Response Time Ramp Test Results File.....	47
Response Time Ramp Distribution (IOPS) Data.....	48
Response Time Ramp Distribution (IOPS) Data (<i>continued</i>)	49
Response Time Ramp Distribution (IOPS) Graph	49
SPC-1 LRT™ Average Response Time (ms) Distribution Data.....	50
SPC-1 LRT™ Average Response Time (ms) Distribution Graph	50
SPC-1 LRT™ (10%) – Measured Intensity Multiplier and Coefficient of Variation	51
Repeatability Test.....	52

SPC-1 Workload Generator Input Parameters	52
Repeatability Test Results File	53
Repeatability 1 LRT – I/O Request Throughput Distribution Data.....	54
Repeatability 1 LRT – I/O Request Throughput Distribution Graph	54
Repeatability 1 LRT –Average Response Time (ms) Distribution Data	55
Repeatability 1 LRT –Average Response Time (ms) Distribution Graph.....	55
Repeatability 1 IOPS – I/O Request Throughput Distribution Data	56
Repeatability 1 IOPS – I/O Request Throughput Distribution Graph.....	56
Repeatability 1 IOPS –Average Response Time (ms) Distribution Data	57
Repeatability 1 IOPS –Average Response Time (ms) Distribution Graph	57
Repeatability 2 LRT – I/O Request Throughput Distribution Data.....	58
Repeatability 2 LRT – I/O Request Throughput Distribution Graph	58
Repeatability 2 LRT –Average Response Time (ms) Distribution Data	59
Repeatability 2 LRT –Average Response Time (ms) Distribution Graph.....	59
Repeatability 2 IOPS – I/O Request Throughput Distribution Data	60
Repeatability 2 IOPS – I/O Request Throughput Distribution Graph.....	60
Repeatability 2 IOPS –Average Response Time (ms) Distribution Data.....	61
Repeatability 2 IOPS –Average Response Time (ms) Distribution Graph	61
Repeatability 1 (LRT) Measured Intensity Multiplier and Coefficient of Variation	62
Repeatability 1 (IOPS) Measured Intensity Multiplier and Coefficient of Variation	62
Repeatability 2 (LRT) Measured Intensity Multiplier and Coefficient of Variation	62
Repeatability 2 (IOPS) Measured Intensity Multiplier and Coefficient of Variation	63
Data Persistence Test.....	64
SPC-1 Workload Generator Input Parameters	64
Data Persistence Test Results File	64
Data Persistence Test Results.....	65
Priced Storage Configuration Availability Date.....	66
Pricing Information.....	66
Tested Storage Configuration (TSC) and Priced Storage Configuration Differences.....	66
Anomalies or Irregularities	66
Appendix A: SPC-1 Glossary	67
“Decimal” (<i>powers of ten</i>) Measurement Units.....	67
“Binary” (<i>powers of two</i>) Measurement Units.....	67
SPC-1 Data Repository Definitions	67
SPC-1 Data Protection Levels	68
SPC-1 Test Execution Definitions	68
I/O Completion Types	70

SPC-1 Test Run Components	70
Appendix B: Customer Tunable Parameters and Options.....	71
Red Hat Enterprise Linux 7.0 (64-bit)	71
Appendix C: Tested Storage Configuration (TSC) Creation	72
Step 1: Create Mapping View, LUN Group, Host Group and Host.....	72
Step 2: Create Disk Domains, Storage Pools, LUNs	73
Step 3: Create Volumes on the Master Host System	73
Step 4: Change the Scheduler on each Host System.....	73
Referenced Scripts.....	74
mklun.sh	74
mkvolume.sh	75
scheduler.sh.....	76
Appendix D: SPC-1 Workload Generator Storage Commands and	
Parameters	77
ASU Pre-Fill.....	77
Primary Metrics and Repeatability Tests	78
SPC-1 Persistence Test.....	79
Appendix E: SPC-1 Workload Generator Input Parameters	80
run.sh	80
Appendix F: Third-Party Quotation.....	83
Priced Storage Configuration	83

AUDIT CERTIFICATION



Xu Zhong
Huawei Technologies Co., Ltd.
Huawei Chengdu Base
No. 1899, Xiyuan Avenue
Chengdu, 611731 P.R. China

April 25, 2016

The SPC Benchmark 1™ Reported Data listed below for the Huawei OceanStor™ 5500 V3 was produced in compliance with the SPC Benchmark 1™ v1.14 Remote Audit requirements.

SPC Benchmark 1™ v1.14 Reported Data	
Tested Storage Product (TSP) Name: Huawei OceanStor™ 5500 V3	
Metric	Reported Result
SPC-1 IOPS™	320,984.01
SPC-1 Price-Performance	\$0.26/SPC-1 IOPS™
Total ASU Capacity	6,764.573 GB
Data Protection Level	Protected 2 (<i>Mirroring</i>)
Total Price (including three-year maintenance)	\$81,900.78
Currency Used	U.S. Dollars
Target Country for availability, sales and support	USA

The following SPC Benchmark 1™ Remote Audit requirements were reviewed and found compliant with 1.14 of the SPC Benchmark 1™ specification:

- A Letter of Good Faith, signed by a senior executive.
- The following Data Repository storage items were verified by information supplied by Huawei Technologies Co., Ltd.:
 - ✓ Physical Storage Capacity and requirements.
 - ✓ Configured Storage Capacity and requirements.
 - ✓ Addressable Storage Capacity and requirements.
 - ✓ Capacity of each Logical Volume and requirements.
 - ✓ Capacity of each Application Storage Unit (ASU) and requirements.
- The total Application Storage Unit (ASU) Capacity was filled with random data, using an auditor approved tool, prior to execution of the SPC-1 Tests.

Gradient Systems, Inc.
643 Bair Island Road, Suite 103
Redwood City, CA 94062
AuditService@storageperformance.org
650.556.9384

AUDIT CERTIFICATION (CONT.)

Huawei OceanStor™ 5500 V3
SPC-1 Audit Certification

Page 2

- An appropriate diagram of the Benchmark Configuration (BC)/Tested Storage Configuration (TSC).
- Listings and commands to configure the Benchmark Configuration/Tested Storage Configuration, including customer tunable parameters that were changed from default values.
- SPC-1 Workload Generator commands and parameters used for the audited SPC Test Runs.
- The following Host System requirements were verified by information supplied by Huawei Technologies Co., Ltd.:
 - ✓ The type of Host Systems including the number of processors and main memory.
 - ✓ The presence and version number of the SPC-1 Workload Generator on each Host System.
 - ✓ The TSC boundary within each Host System.
- The execution of each Test, Test Phase, and Test Run was found compliant with all of the requirements and constraints of Clauses 4, 5, and 11 of the SPC-1 Benchmark Specification.
- The Test Results Files and resultant Summary Results Files received from Huawei Technologies Co., Ltd. for each of following were authentic, accurate, and compliant with all of the requirements and constraints of Clauses 4 and 5 of the SPC-1 Benchmark Specification:
 - ✓ Data Persistence Test
 - ✓ Sustainability Test Phase
 - ✓ IOPS Test Phase
 - ✓ Response Time Ramp Test Phase
 - ✓ Repeatability Test
- There were no differences between the Tested Storage Configuration (TSC) and Priced Storage Configuration.
- The submitted pricing information met all of the requirements and constraints of Clause 8 of the SPC-1 Benchmark Specification.
- The Full Disclosure Report (FDR) met all of the requirements in Clause 9 of the SPC-1 Benchmark Specification.
- This successfully audited SPC measurement is not subject to an SPC Confidential Review.

Audit Notes:

There were no audit notes or exceptions.

Respectfully,

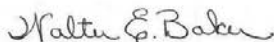

Walter E. Baker
SPC Auditor

Storage Performance Council
643 Bair Island Road, Suite 103
Redwood City, CA 94062
AuditService@storageperformance.org
650.556.9384

LETTER OF GOOD FAITH



©Huawei Technologies Co., Ltd.
Huawei Industrial Base, Bantian, Longgang
Shenzhen city
Guangdong province
China
Tel: 0086-755-28780808
<http://www.huawei.com/en/>

Date: April 7, 2016

From: Huawei Technologies Co., Ltd.

To: Walter E. Baker, SPC Auditor
Gradient Systems, Inc.
643 Bair Island Road, Suite 103
Redwood City, CA 94063

Subject: SPC-1 Letter of Good Faith for the Huawei OceanStor 5500 V3

Huawei Technologies Co., Ltd. is the SPC-1 Test Sponsor for the above listed product. To the best of our knowledge and belief, the required SPC-1 benchmark results and materials we have submitted for that product are complete, accurate, and in full compliance with V1.14 of the SPC-1 benchmark specification.

In addition, we have reported any items in the Benchmark Configuration and execution of the benchmark that affected the reported results even if the items are not explicitly required to be disclosed by the SPC-1 benchmark specification.

Signed:



Fan Ruiqi
President of Storage Product Line

Date:

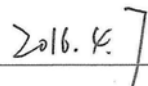

2016.4.7

EXECUTIVE SUMMARY

Test Sponsor and Contact Information

Test Sponsor and Contact Information	
Test Sponsor Primary Contact	Huawei Technologies Co., Ltd. – http://www.huawei.com/en/ Xu Zhong – xuzhong@huawei.com Huawei Chengdu Base No. 1899, Xiyuan Avenue Chengdu, 611731 P.R. China Phone: 86 28 65281927 FAX: 86 28 62282516
Test Sponsor Alternate Contact	Huawei Technologies Co., Ltd. – http://www.huawei.com/en/ Li Huan – tomas.l@huawei.com Huawei Chengdu Base No. 1899, Xiyuan Avenue Chengdu, 611731 P.R. China Phone: 86 28 65281927 FAX: 86 28 62282516
Auditor	Storage Performance Council – http://www.storageperformance.org Walter E. Baker – AuditService@StoragePerformance.org 643 Bair Island Road, Suite 103 Redwood City, CA 94063 Phone: (650) 556-9384 FAX: (650) 556-9385

Revision Information and Key Dates

Revision Information and Key Dates	
SPC-1 Specification revision number	V1.14
SPC-1 Workload Generator revision number	V2.3.0
Date Results were first used publicly	April 26, 2016
Date the FDR was submitted to the SPC	April 26, 2016
Date the Priced Storage Configuration is available for shipment to customers	currently available
Date the TSC completed audit certification	April 25, 2016

Tested Storage Product (TSP) Description

The Huawei OceanStor™ 5500 V3 offers a cloud architecture-oriented operating system, high-performance hardware platform, and a complete suite of smart management software. The product is scalable to eight controllers, 512 GB cache, a maximum of 750 storage devices, with a variety of interfaces, including 16 Gbit/s FC, 56 Gbit/s InfiniBand, PCIe 3.0, 12 Gbit/s SAS, and smart I/O cards.

The Huawei OceanStor™ 5500 V3 is a perfect storage system for large OLTP/OLAP databases, file sharing, and cloud computing in the government, finance, telecom, energy, and media industries.

OceanStor OS, the Huawei OceanStor storage operating system, enables Huawei storage products evolve to the future cloud architecture and deliver the core business platform. It supports all OceanStor Storage arrays, specifically, for managing the underlying infrastructure, the physical space and logical space. OceanStor OS delivers intelligent and convergent services and multiple SLAs to the application scenarios, including SAN and NAS convergence, all-level storage convergence, performance and capacity convergence, primary and backup storage convergence, and heterogeneous storage convergence. OceanStor OS helps customers evolve their traditional storage to cloud services in the future.

Summary of Results

SPC-1 Reported Data	
Tested Storage Product (TSP) Name: Huawei OceanStor™ 5500 V3	
Metric	Reported Result
SPC-1 IOPS™	320,984.01
SPC-1 Price-Performance™	\$0.26/SPC-1 IOPS™
Total ASU Capacity	6,764.573 GB
Data Protection Level	Protected 2 (<i>Mirroring</i>)
Total Price	\$81,900.78
Currency Used	U.S. Dollars
Target Country for availability, sales and support	USA

SPC-1 IOPS™ represents the maximum I/O Request Throughput at the 100% load point.

SPC-1 Price-Performance™ is the ratio of **Total Price** to SPC-1 IOPS™.

Total ASU (Application Storage Unit) **Capacity** represents the total storage capacity available to be read and written in the course of executing the SPC-1 benchmark.

A **Data Protection Level** of **Protected 2** using *Mirroring* configures two or more identical copies of user data.

***Protected 2:** The single point of failure of any **component** in the configuration will not result in permanent loss of access to or integrity of the SPC-1 Data Repository.*

Total Price includes the cost of the Priced Storage Configuration plus three years of hardware maintenance and software support as detailed on page 17.

Currency Used is formal name for the currency used in calculating the **Total Price** and **SPC-1 Price-Performance™**. That currency may be the local currency of the **Target Country** or the currency of a difference country (*non-local currency*).

The **Target Country** is the country in which the Priced Storage Configuration is available for sale and in which the required hardware maintenance and software support is provided either directly from the Test Sponsor or indirectly via a third-party supplier.

Storage Capacities, Relationships, and Utilization

The following four charts and table document the various storage capacities, used in this benchmark, and their relationships, as well as the storage utilization values required to be reported.

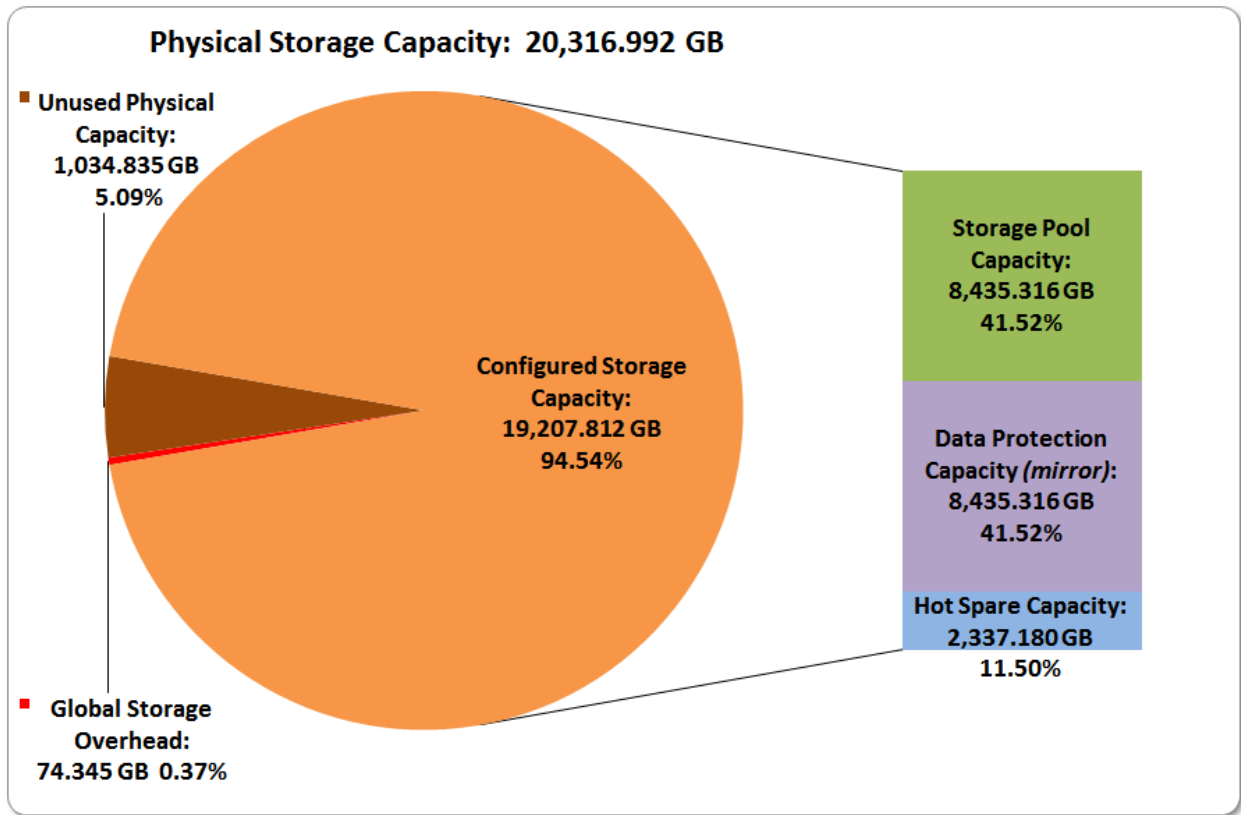

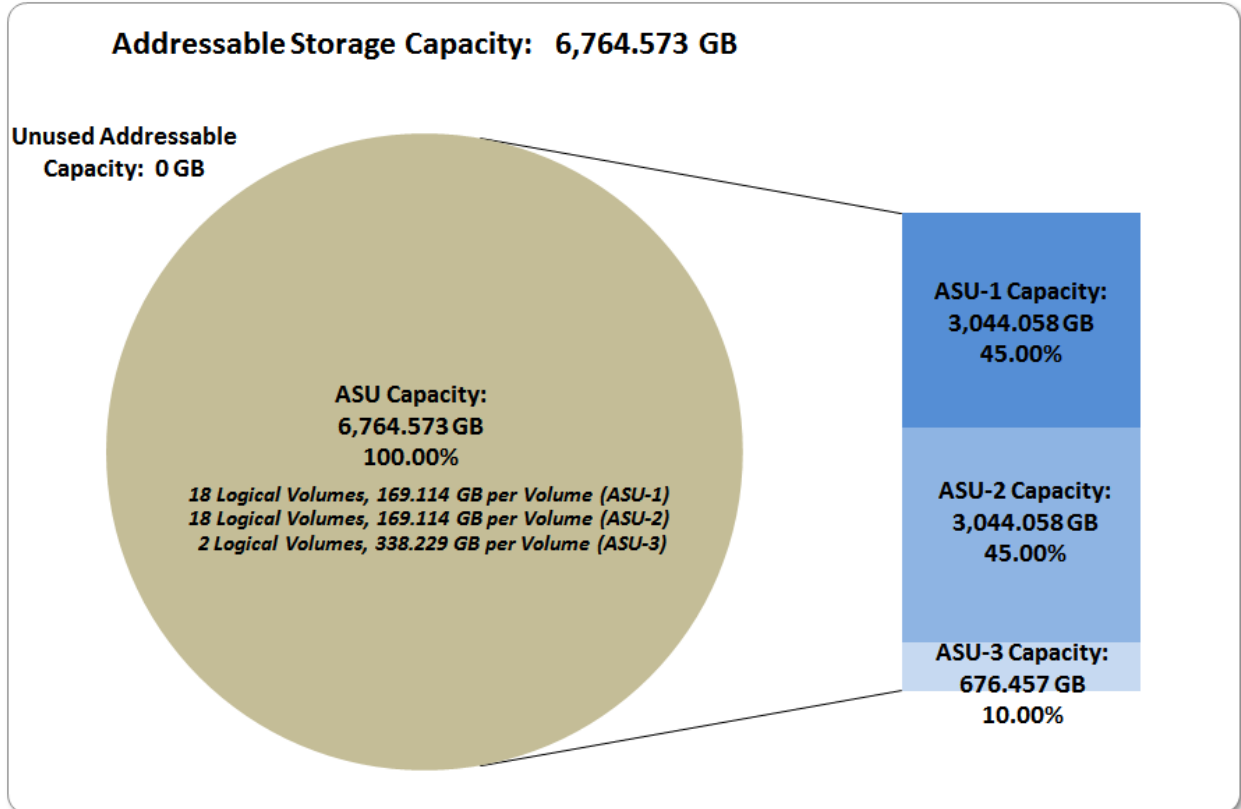
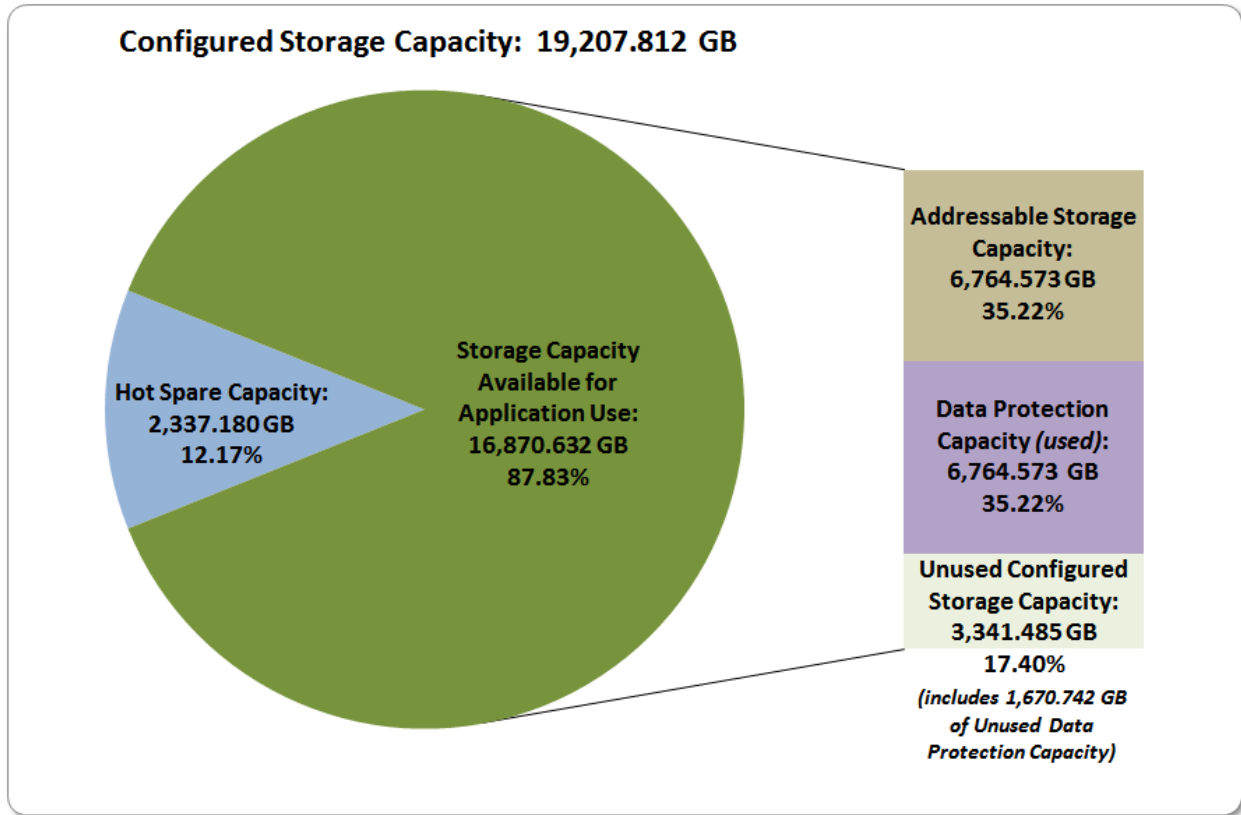

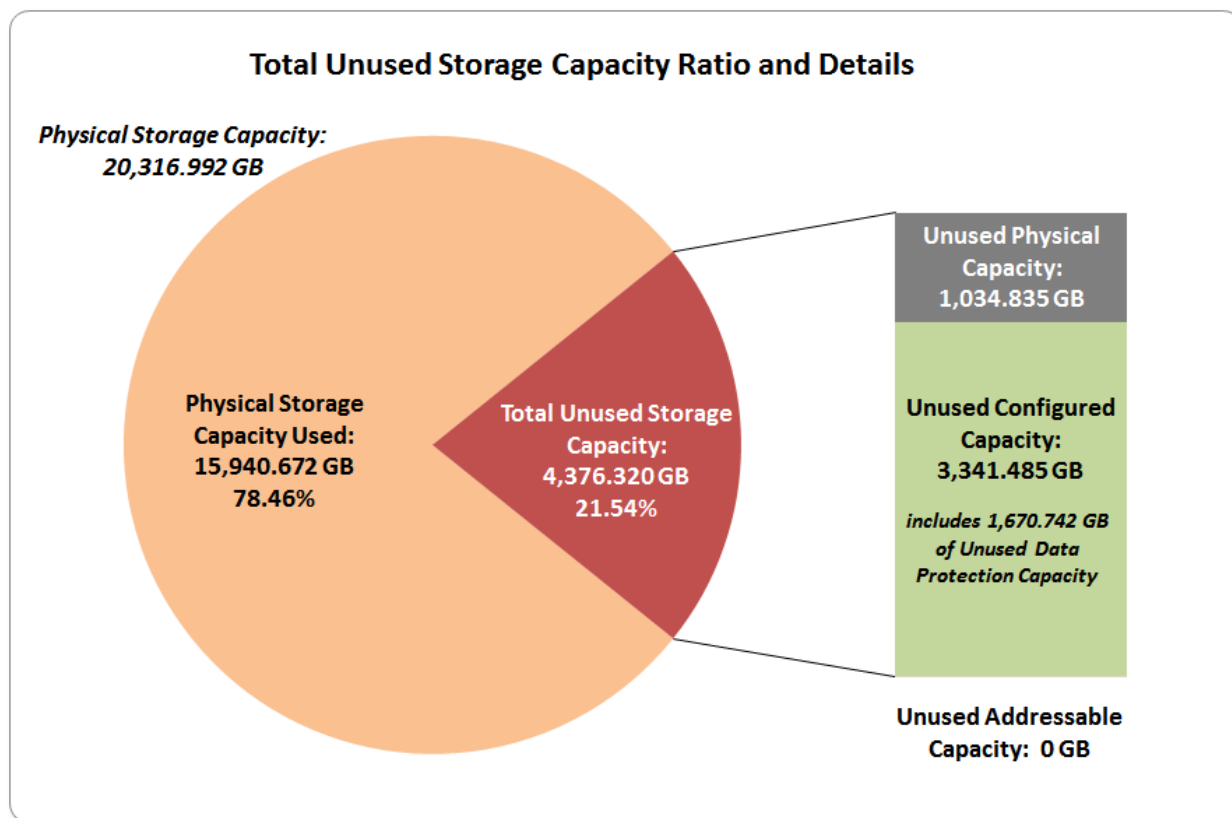

SPC-1 Storage Capacity Utilization	
Application Utilization	33.30%
Protected Application Utilization	66.59%
Unused Storage Ratio	21.54%

Application Utilization: Total ASU Capacity (6,764.573 GB) divided by Physical Storage Capacity (20,316.992 GB).

Protected Application Utilization: (Total ASU Capacity (6,764.573 GB) plus total Data Protection Capacity (8,435.316 GB) minus unused Data Protection Capacity (1,670.742 GB)) divided by Physical Storage Capacity (20,316.992 GB).

Unused Storage Ratio: Total Unused Capacity (4,376.320 GB) divided by Physical Storage Capacity (20,316.992 GB) and may not exceed 45%.

Detailed information for the various storage capacities and utilizations is available on pages 30-31.

Response Time – Throughput Curve

The Response Time-Throughput Curve illustrates the Average Response Time (milliseconds) and I/O Request Throughput at 100%, 95%, 90%, 80%, 50%, and 10% of the workload level used to generate the SPC-1 IOPS™ metric.

The Average Response Time measured at any of the above load points cannot exceed 30 milliseconds or the benchmark measurement is invalid.

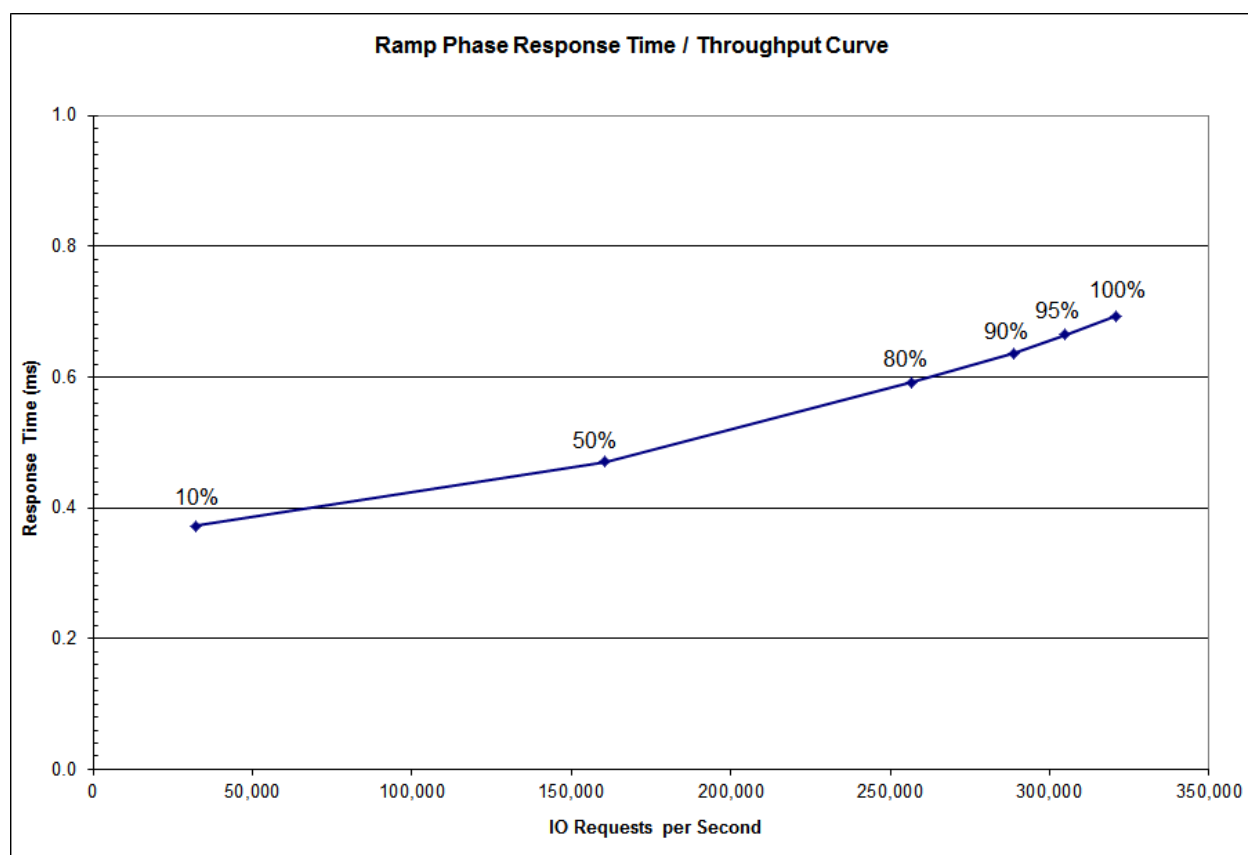

Response Time – Throughput Data

	10% Load	50% Load	80% Load	90% Load	95% Load	100% Load
I/O Request Throughput	32,105.94	160,494.97	256,786.94	288,907.69	304,962.40	320,984.01
Average Response Time (ms):						
All ASUs	0.37	0.47	0.59	0.64	0.67	0.69
ASU-1	0.36	0.47	0.61	0.66	0.69	0.72
ASU-2	0.40	0.52	0.66	0.71	0.74	0.77
ASU-3	0.39	0.44	0.52	0.56	0.58	0.61
Reads	0.37	0.53	0.72	0.79	0.82	0.85
Writes	0.38	0.43	0.51	0.54	0.57	0.59

Priced Storage Configuration Pricing

No.	Model	Description	Qty.	Unit Price (USD)	Total Price (USD)
1	Phase				
1	Location				
1.1	OceanStor 5500 V3 Storage System				
1.1.1	Engine				
	55V3-128G-AC2-8	5500 V3(2U,Dual Ctrl,AC,128GB,SmartIO,8*8Gb FC,25*2.5",SPE33C0225)	2	12,217.20	24,434.40
1.1.2	Expand Interface Module				
	SMARTIO10ETH	4 port SmartIO I/O module(SFP+,10Gb Eth/FCoE(VN2VF)/Scale-out)	4	1,310.16	5,240.64
1.1.3	Disk Components				
	SSDM-400G2S-A1	SSD Midrange 400GB 2.5" SAS 6G Disk Unit	50	710.40	35,520.00
1.1.4	Installation Material				
	SN2F01FCPC	Patch Cord,DLC/PC,DLC/PC,Multi-mode,3m,A1a.2,2mm,OM3 bending insensitive	24	11.00	264.00
1.1.5	HBA				
	N8GHBA000	QLOGIC QLE2562 HBA Card,PCIE,8Gbps DualPort ,Fiber Channel Multimode LC Optic Interface,English Manual, No Drive CD	8	1,000.00	8,000.00
1.1.6	Storage Software				
	LIC-5500V3-BS	Basic Software License for Block(Include Device Management,SmartThin,SmartMulti-tenant,SmartMigration,SmartErase,SmartMotion,Ultrath, Cloud Service)	1	788.16	788.16
	LIC-5500V3-PATH	OceanStor HW UltraPath Software License	1	945.60	945.60
Total of Product					75,192.80
1.1.7	Maintenance Support Service				
	02350HYS-88134ULJ-3	5500 V3(2U,Dual Ctrl,AC,128GB,SmartIO,8*8Gb FC,25*2.5",SPE33C0225)-Warranty Upgrade To Hi-Care Onsite Premier 24x7x4H Engineer Onsite Service-3 Year(s)	2	3,059.99	6,119.98
	88032QRN-88134UHK-3	OceanStor HW UltraPath Software License-Hi-Care Application Software Upgrade Support Service-3 Year(s)	1	294.00	294.00
	88032QRA-88134UHK-3	Basic Software License for Block (Includes Device Management,SmartThin,SmartMulti-tenant, SmartMigration,SmartErase,SmartMotion,Cloud Service) Hi-Care Application Software Upgrade Support Service-3 Year(s)	1	294.00	294.00
Total of Service (3 years)					6,707.98
Total Price					81,900.78
Notes:Hi-Care Premier On-Site Service include: 7*24 Technical Assistance Center Access. Access to all new software updates and Online Support. 24*7*4 Hours Onsite Hardware Replacement.					

Huawei Technologies Co., Ltd. only sells its products to third-party resellers, who in turn, sell those products to U.S. customers. The above pricing, which also includes the required three-year maintenance and support, was obtained from one of those third-party resellers. See page [83](#) ([Appendix F: Third-Party Quotation](#)) for a copy of the third-party reseller quotation.

The above pricing includes hardware maintenance and software support for three years, 7 days per week, 24 hours per day. The hardware maintenance and software support provides the following:

- Acknowledgement of new and existing problems within four (4) hours.
- Onsite presence of a qualified maintenance engineer or provision of a customer replaceable part within four (4) hours of the above acknowledgement for any hardware failure that results in an inoperative Price Storage Configuration that can be remedied by the repair or replacement of a Priced Storage Configuration component.

Differences between the Tested Storage Configuration (TSC) and Priced Storage Configuration

There were no differences between the Tested Storage Configuration and the Priced Storage Configuration.

Priced Storage Configuration Diagram

8 – QLogic dual-ported QLE2562 FC HBAs



16 – 8 Gb FC connections
(2 connections/HBA)
(4 connection/Controller)



2 – 2U System Enclosures

2 – Engines

(1 Engine per System Enclosure)

4 – Active-Active Controllers

(2 controllers per Engine)

4 – 4-port 8Gb Smart I/O modules
(built-in FC, 1 module per Controller)

256 GB cache *(64 GB per Controller)*

4 – 4-port 10Gb Smart I/O modules
(Eth/FCoE) (1 module per Controller)

50 – 400GB SSD drives
(25 SSDs per System Enclosure)

Huawei OceanStor™ 5500 V3

Priced Storage Configuration Components

Priced Storage Configuration
OceanStor UltraPath
8 – QLogic QLE2562 dual-port, 8 Gbps, FC HBAs
Huawei OceanStor™ 5500 V3 2 – 2U System Enclosures 2 – Engines (<i>CTE0 and CTE1</i>) (<i>1 Engine per System Enclosure</i>) 4 – Active-Active Controllers (<i>0A, 0B, 1A and 1B</i>) (<i>2 Controllers per Engine</i>) each controller includes: 64 GB cache (<i>256 GB total</i>) 1 – 4-port 10Gb Smart I/O modules (<i>Eth/FCoE</i>) (<i>used for inter-controller connectivity</i>) (<i>4 modules total, 4 ports per controller</i>) (<i>16 ports total and used</i>) 1 – 4-port 8Gb Smart I/O module (<i>built-in FC</i>) (<i>4 modules total, 4 ports per controller</i>) (<i>16 ports total and used</i>)
50 – 400 GB, 2.5" SSD drives (<i>25 SSDs per System Enclosure</i>)

Engine, Controller, Eth/FCoE module/active port relationships and Controller-to-Controller Eth/FCoE connection details, used in the Benchmark Configuration, are listed on pages [25-27](#).

In each of the following sections of this document, the appropriate Full Disclosure Report requirement, from the SPC-1 benchmark specification, is stated in italics followed by the information to fulfill the stated requirement.

CONFIGURATION INFORMATION

Benchmark Configuration (BC)/Tested Storage Configuration (TSC) Diagram

Clause 9.4.3.4.1

A one page Benchmark Configuration (BC)/Tested Storage Configuration (TSC) diagram shall be included in the FDR...

The Benchmark Configuration (BC)/Tested Storage Configuration (TSC) is illustrated on page [22 \(Benchmark Configuration/Tested Storage Configuration Diagram\)](#).

Storage Network Configuration

Clause 9.4.3.4.1

...

- 5. If the TSC contains network storage, the diagram will include the network configuration. If a single diagram is not sufficient to illustrate both the Benchmark Configuration and network configuration in sufficient detail, the Benchmark Configuration diagram will include a high-level network illustration as shown in Figure 9-8. In that case, a separate, detailed network configuration diagram will also be included as described in Clause 9.4.3.4.2.*

Clause 9.4.3.4.2

If a storage network was configured as a part of the Tested Storage Configuration and the Benchmark Configuration diagram described in Clause 9.4.3.4.1 contains a high-level illustration of the network configuration, the Executive Summary will contain a one page topology diagram of the storage network as illustrated in Figure 9-9.

The Tested Storage Configuration (TSC) was configured with direct-attached storage.

Host System(s) and Tested Storage Configuration (TSC) Table of Components

Clause 9.4.3.4.3

The FDR will contain a table that lists the major components of each Host System and the Tested Storage Configuration (TSC).

The Host System(s) and TSC table of components may be found on page [23 \(Host System and Tested Storage Configuration Components\)](#).

Benchmark Configuration/Tested Storage Configuration Diagram

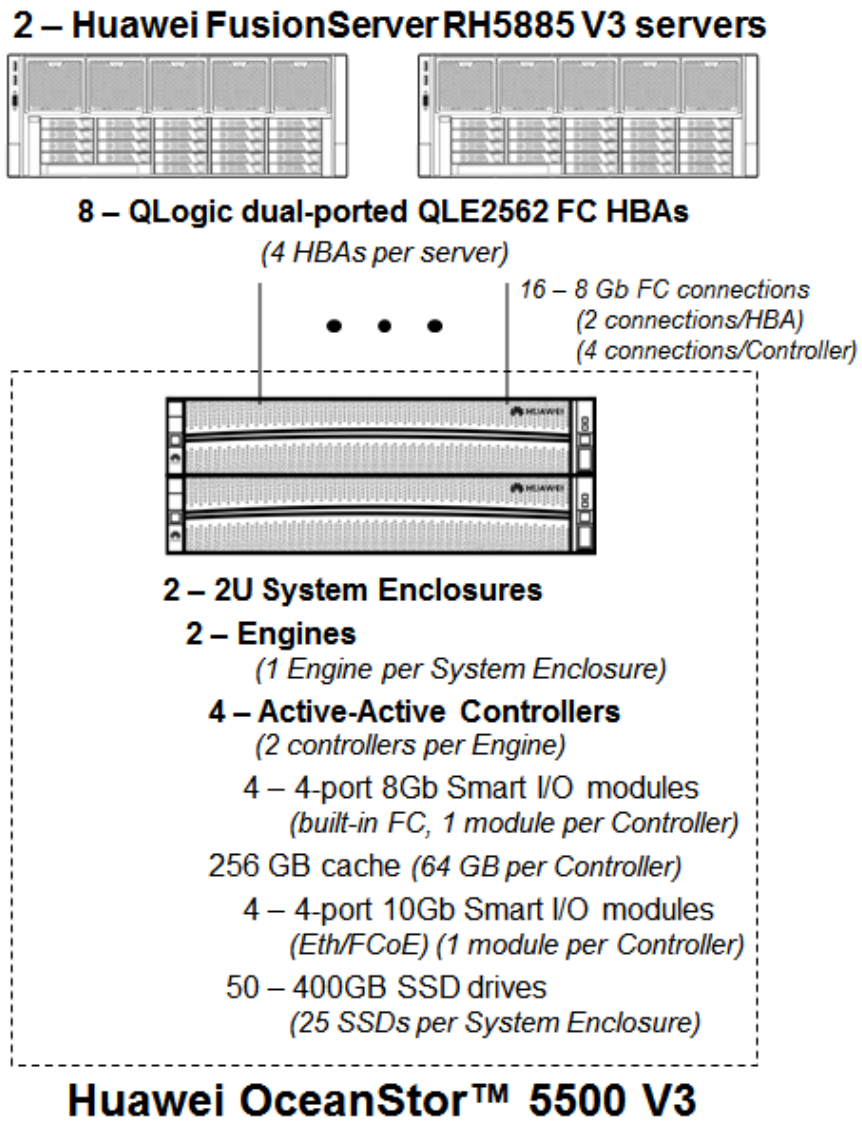

Host System and Tested Storage Configuration Components

Host System
<p>2 – Huawei FusionServer RH5885 V3 servers, each with:</p> <ul style="list-style-type: none"> 4 – Intel® Xeon® 2.00 GHz processor E7-4820 V2 each with 8 cores, 16 MB cache 512 GB main memory Red Hat Enterprise Linux Server release 7.0 x86_64 PCIe
Tested Storage Configuration
OceanStor UltraPath
8 – QLogic QLE2562 dual-port, 8 Gbps, FC HBAs
<p>Huawei OceanStor™ 5500 V3</p> <ul style="list-style-type: none"> 2 – 2U System Enclosures <ul style="list-style-type: none"> 2 – Engines (<i>CTE0 and CTE1</i>) (1 Engine per System Enclosure) 4 – Active-Active Controllers (<i>0A, 0B, 1A and 1B</i>) (2 Controllers per Engine) each controller includes: <ul style="list-style-type: none"> 64 GB cache (<i>256 GB total</i>) 1 – 4-port 10Gb Smart I/O modules (<i>Eth/FCoE</i>) (used for inter-controller connectivity) (4 modules total, 4 ports per controller) (16 ports total and used) 1 – 4-port 8Gb Smart I/O module (<i>built-in FC</i>) (4 modules total, 4 ports per controller) (16 ports total and used)
50 – 400 GB, 2.5" SSD drives (<i>25 SSDs per System Enclosure</i>)

Host System, HBA, Engine, Controller, FC Host Port Module details and Host System HBA/Host Port FC connections are listed on page [24](#).

Engine, Controller, Eth/FCoE module/active port relationships and Controller-to-Controller Eth/FCoE connection details are listed on pages [25-27](#).

Benchmark Configuration/Tested Storage Configuration Connections

Host System, FC HBA, Engine, Controller, FC Host Port Module/Ports

The Benchmark Configuration/Tested Storage Configuration includes:

- 2 Host Systems: **Host System 1** and **Host System 2**
- 8 FC HBAs (*2 ports per HBA, 16 ports total*)
4 FC HBAs per Host System: **HBA0 – HBA3** (*arbitrary names for identification*)
8 ports per Host System

Huawei OceanStor™ 5500 V3

- 2 Engines: **CTE0** and **CTE1**
- 4 Controllers: **0A, 0B, 1A** and **1B**
2 Controllers per Engine: **CTE0.0A** and **CTE0.0B**; **CTE1.1A** and **CTE1.1B**
- 4 FC Host Port Modules:
CTE0.A, CTE0.B, CTE1.A and **CTE1.B**
4 ports per Module (**H0 – H3**), 1 Module per Controller:
CTE0.A: CTE0.A.H0 – H3
CTE0.B: CTE0.B.H0 – H3
CTE1.A: CTE1.A.H0 – H3
CTE1.B: CTE1.B.H0 – H3

Host System to Controller Host Port FC Connections

Each Host System has 2 FC HBA connections to each controller, as described below, which utilizes all 16 HBA and controller FC port.

- **Host System 1**
 - **HBA0:** 2 HBA ports connected to any 2 ports in controller **0A**, FC module **CTE0.A**
 - **HBA1:** 2 HBA ports connected to any 2 ports in controller **0B**, FC module **CTE0.B**
 - **HBA2:** 2 HBA ports connected to any 2 ports in controller **1A**, FC module **CTE1.A**
 - **HBA4:** 2 HBA ports connected to any 2 ports in controller **1B**, FC module **CTE1.B**
- **Host System 2**
 - **HBA0:** 2 HBA ports connected to any 2 ports in controller **0A**, FC module **CTE0.A**
 - **HBA1:** 2 HBA ports connected to any 2 ports in controller **0B**, FC module **CTE0.B**
 - **HBA2:** 2 HBA ports connected to any 2 ports in controller **1A**, FC module **CTE1.A**
 - **HBA4:** 2 HBA ports connected to any 2 ports in controller **1B**, FC module **CTE1.B**

Engine, Controller, Eth/FCoE Module/Active Port Relationships

The relationships between the Engines, Controllers, Eth/FCoE Modules/Active Ports are listed below and illustrated in the following table.

- 2 Engines: **CTE0** and **CTE1**
- 4 Controllers: **0A, 0B, 1A** and **1B**
 2 Controllers per Engine: **CTE0.0A** and **CTE0.0B**; **CTE1.1A** and **CTE1.1B**
- 4 Eth/FCoE Modules:
CTE0.A.IOM1, CTE0.B.IOM1, CTE1.A.IOM1 and **CTE1.B.IOM1**
 1 Module per Controller, 4 ports per Module (**P0 – P3**):
CTE0.A.IOM1: CTE0.A.IOM1.P0 – P3
CTE0.B.IOM1: CTE0.B.IOM1.P0 – P3
CTE1.A.IOM1: CTE1.A.IOM1.P0 – P3
CTE1.B.IOM1: CTE1.B.IOM1.P0 – P3

Engine	Controller	Eth/FCoE Module	Active Port
CTE0	0A	CTE0.A.IOM1	CTE0.A.IOM1.P0
			CTE0.A.IOM1.P1
			CTE0.A.IOM1.P2
			CTE0.A.IOM1.P3
	0B	CTE0.B.IOM1	CTE0.B.IOM1.P0
			CTE0.B.IOM1.P1
			CTE0.B.IOM1.P2
			CTE0.B.IOM1.P3
CTE1	1A	CTE1.A.IOM1	CTE1.A.IOM1.P0
			CTE1.A.IOM1.P1
			CTE1.A.IOM1.P2
			CTE1.A.IOM1.P3
	1B	CTE1.B.IOM1	CTE1.B.IOM1.P0
			CTE1.B.IOM1.P1
			CTE1.B.IOM1.P2
			CTE1.B.IOM1.P3

Controller-to-Controller Eth/FCoE Connections

The following table and diagram documents and illustrates the Eth/FCoE connections between each Controller to scale-out from two to four Controllers.

Controller-to-Controller Eth/FCoE Connections

Engine CTE1	Engine CTE0			
	Controller 0A			
	CTE0.A.IOM1.P0	CTE0.A.IOM1.P1	CTE0.A.IOM1.P2	CTE0.A.IOM1.P3
Controller 1A				
CTE1.A.IOM1.P0	connection			
CTE1.A.IOM1.P1		connection		
CTE1.A.IOM1.P2				
CTE1.A.IOM1.P3				
Controller 1B				
CTE1.B.IOM1.P0				
CTE1.B.IOM1.P1				
CTE1.B.IOM1.P2			connection	
CTE1.B.IOM1.P3				connection

Engine CTE1	Engine CTE0			
	Controller 0B			
	CTE0.B.IOM1.P0	CTE0.B.IOM1.P1	CTE0.B.IOM1.P2	CTE0.B.IOM1.P3
Controller 1A				
CTE1.A.IOM1.P0				
CTE1.A.IOM1.P1				
CTE1.A.IOM1.P2			connection	
CTE1.A.IOM1.P3				connection
Controller 1B				
CTE1.B.IOM1.P0	connection			
CTE1.B.IOM1.P1		connection		
CTE1.B.IOM1.P2				
CTE1.B.IOM1.P3				

Engine CTE0: Controller 0A, Eth/FCoE Module CTE0.A.IOM1 Ports P0-P3
 Controller 0B, Eth/FCoE Module CTE0.B.IOM1 Ports P0-P3
Engine CTE1: Controller 1A, Eth/FCoE Module CTE1.A.IOM1 Ports P0-P3
 Controller 1B, Eth/FCoE Module CTE1.B.IOM1 Ports P0-P3

Controller to Controller Eth/FCoE Connections (*continued*)

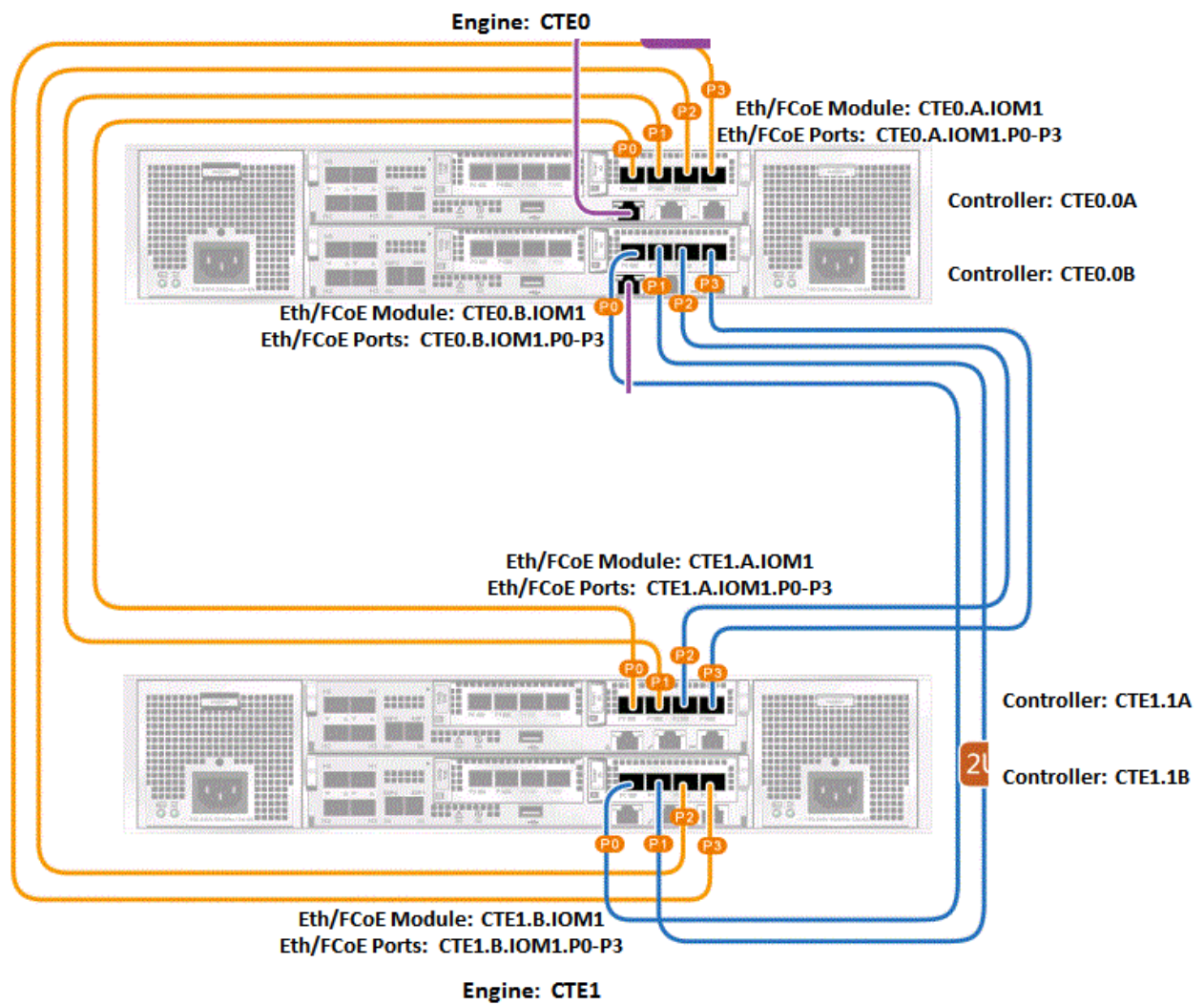

Customer Tunable Parameters and Options

Clause 9.4.3.5.1

All Benchmark Configuration (BC) components with customer tunable parameter and options that have been altered from their default values must be listed in the FDR. The FDR entry for each of those components must include both the name of the component and the altered value of the parameter or option. If the parameter name is not self-explanatory to a knowledgeable practitioner, a brief description of the parameter's use must also be included in the FDR entry.

[Appendix B: Customer Tunable Parameters and Options](#) on page 71 contains the customer tunable parameters and options that have been altered from their default values for this benchmark.

Tested Storage Configuration (TSC) Description

Clause 9.4.3.5.2

The FDR must include sufficient information to recreate the logical representation of the TSC. In addition to customer tunable parameters and options (Clause 4.2.4.5.3), that information must include, at a minimum:

- A diagram and/or description of the following:
 - All physical components that comprise the TSC. Those components are also illustrated in the BC Configuration Diagram in Clause 9.2.4.4.1 and/or the Storage Network Configuration Diagram in Clause 9.2.4.4.2.
 - The logical representation of the TSC, configured from the above components that will be presented to the Workload Generator.
- Listings of scripts used to create the logical representation of the TSC.
- If scripts were not used, a description of the process used with sufficient detail to recreate the logical representation of the TSC.

[Appendix C: Tested Storage Configuration \(TSC\) Creation](#) on page 72 contains the detailed information that describes how to create and configure the logical TSC.

SPC-1 Workload Generator Storage Configuration

Clause 9.4.3.5.3

The FDR must include all SPC-1 Workload Generator storage configuration commands and parameters.

The SPC-1 Workload Generator storage configuration commands and parameters for this measurement appear in [Appendix D: SPC-1 Workload Generator Storage Commands and Parameters](#) on page 77.

ASU Pre-Fill

Clause 5.3.3

Each of the three SPC-1 ASUs (ASU-1, ASU-2 and ASU-3) is required to be completely filled with specified content prior to the execution of audited SPC-1 Tests. The content is required to consist of random data pattern such as that produced by an SPC recommended tool.

The configuration file used to complete the required ASU pre-fill appears in [Appendix D: SPC-1 Workload Generator Storage Commands and Parameters](#) on page 77.

SPC-1 DATA REPOSITORY

This portion of the Full Disclosure Report presents the detailed information that fully documents the various SPC-1 storage capacities and mappings used in the Tested Storage Configuration. [SPC-1 Data Repository Definitions](#) on page [67](#) contains definitions of terms specific to the SPC-1 Data Repository.

Storage Capacities and Relationships

Clause 9.4.3.6.1

Two tables and four charts documenting the storage capacities and relationships of the SPC-1 Storage Hierarchy (Clause 2.1) shall be included in the FDR. ... The capacity value in each chart may be listed as an integer value, for readability, rather than the decimal value listed in the table below.

SPC-1 Storage Capacities

The Physical Storage Capacity consisted of 20,316.992 GB distributed over 50 solid state drives (SSDs) each with a formatted capacity of 406.340 GB. There was 1,034.835 GB (5.09%) of Unused Storage within the Physical Storage Capacity. Global Storage Overhead consisted of 74.345 GB (0.37%) of the Physical Storage Capacity. There was 3,341.485 GB (17.40%) of Unused Storage within the Configured Storage Capacity. The Total ASU Capacity utilized 100% of the Addressable Storage Capacity resulting in 0.00 GB (0.00%) of Unused Storage within the Addressable Storage Capacity. The Data Protection (*Mirroring*) capacity was 8,435.316 GB of which 6,764.573 GB was utilized. The total Unused Storage capacity was 4,376.320 GB.

Note: The configured Storage Devices may include additional storage capacity reserved for system overhead, which is not accessible for application use. That storage capacity may not be included in the value presented for Physical Storage Capacity.

SPC-1 Storage Capacities		
Storage Hierarchy Component	Units	Capacity
Total ASU Capacity	Gigabytes (GB)	6,764.573
Addressable Storage Capacity	Gigabytes (GB)	6,764.573
Configured Storage Capacity	Gigabytes (GB)	19,207.812
Physical Storage Capacity	Gigabytes (GB)	20,316.992
Data Protection (<i>Mirroring</i>)	Gigabytes (GB)	8,435.316
Required Storage (<i>sparing</i>)	Gigabytes (GB)	2,337.180
Global Storage Overhead	Gigabytes (GB)	76.345
Total Unused Storage	Gigabytes (GB)	4,376.320

SPC-1 Storage Hierarchy Ratios

	Addressable Storage Capacity	Configured Storage Capacity	Physical Storage Capacity
Total ASU Capacity	100.00%	35.22%	33.30%
Required for Data Protection (<i>Mirroring</i>)		43.92%	41.52%
Addressable Storage Capacity		35.22%	33.30%
Required Storage (<i>sparing</i>)		121.17%	11.50%
Configured Storage Capacity			94.54%
Global Storage Overhead			0.37%
Unused Storage:			
Addressable	0.00%		
Configured		17.40%	
Physical			5.09%

SPC-1 Storage Capacity Charts

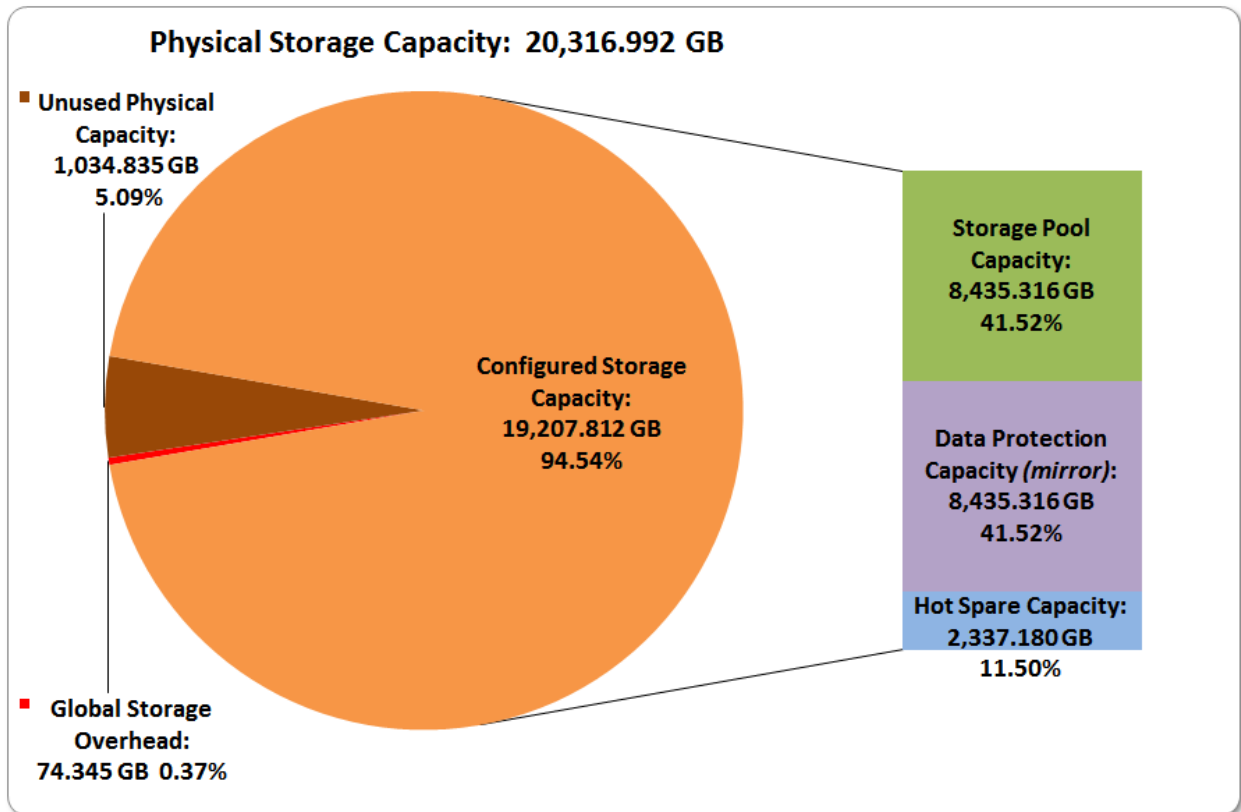

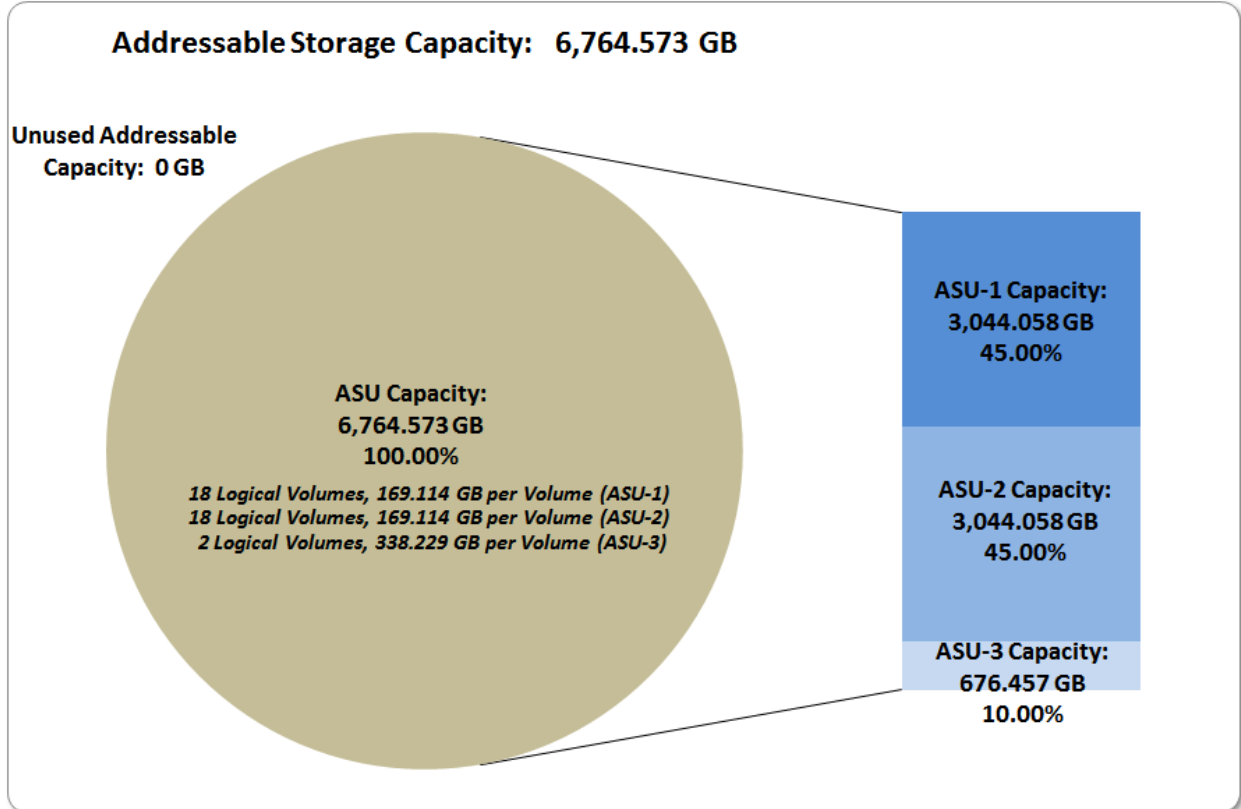
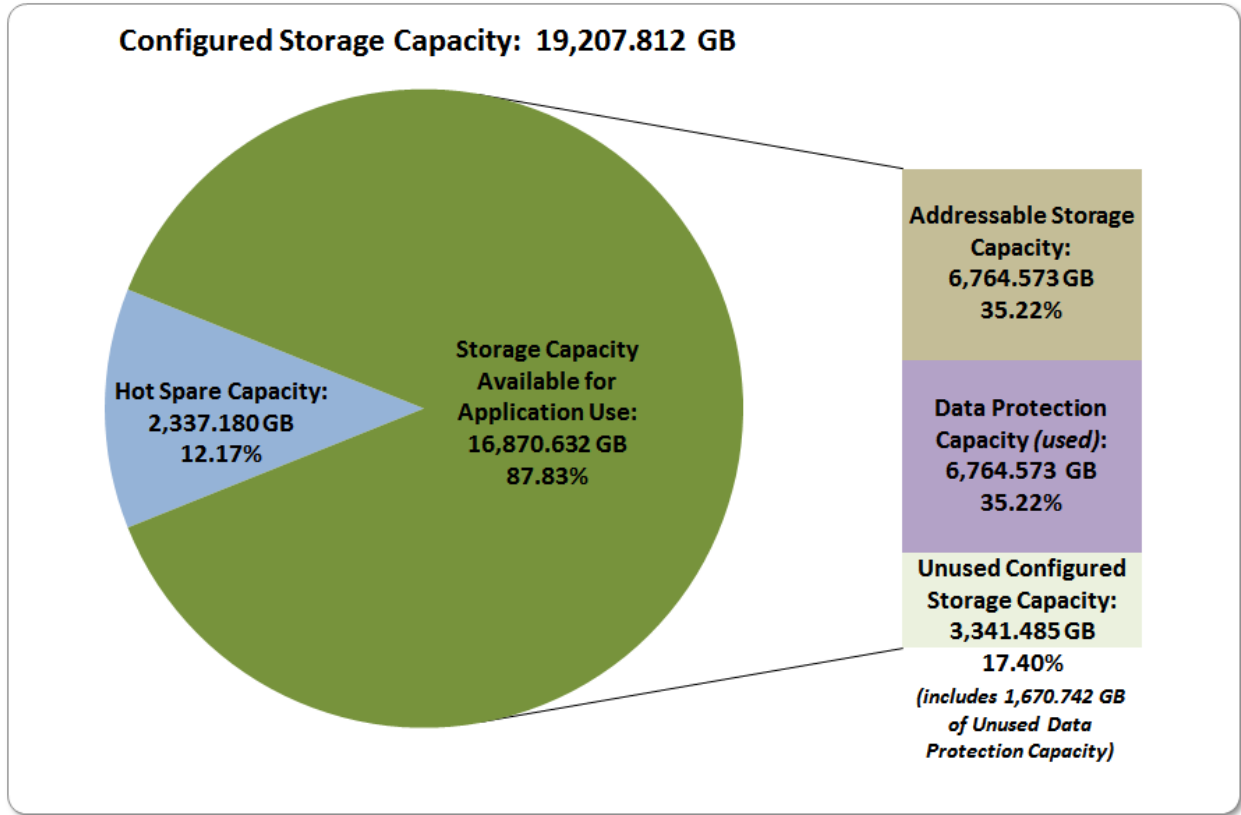

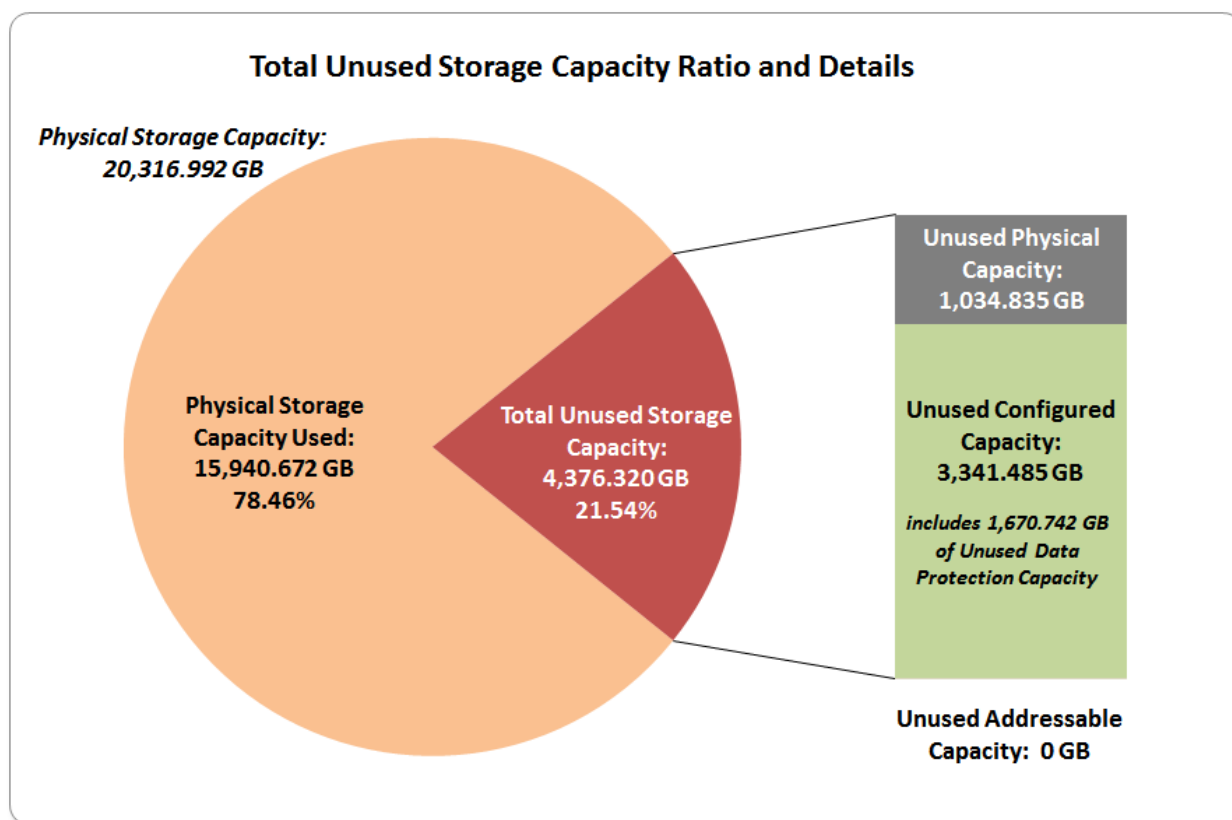

Storage Capacity Utilization

Clause 9.4.3.6.2

The FDR will include a table illustrating the storage capacity utilization values defined for Application Utilization (Clause 2.8.1), Protected Application Utilization (Clause 2.8.2), and Unused Storage Ratio (Clause 2.8.3).

Clause 2.8.1

Application Utilization is defined as Total ASU Capacity divided by Physical Storage Capacity.

Clause 2.8.2

Protected Application Utilization is defined as (Total ASU Capacity plus total Data Protection Capacity minus unused Data Protection Capacity) divided by Physical Storage Capacity.

Clause 2.8.3

Unused Storage Ratio is defined as Total Unused Capacity divided by Physical Storage Capacity and may not exceed 45%.

SPC-1 Storage Capacity Utilization	
Application Utilization	33.30%
Protected Application Utilization	66.59%
Unused Storage Ratio	21.54%

Logical Volume Capacity and ASU Mapping

Clause 9.4.3.6.3

A table illustrating the capacity of each ASU and the mapping of Logical Volumes to ASUs shall be provided in the FDR. ... Logical Volumes shall be sequenced in the table from top to bottom per its position in the contiguous address space of each ASU. The capacity of each Logical Volume shall be stated. ... In conjunction with this table, the Test Sponsor shall provide a complete description of the type of data protection (see Clause 2.4.5) used on each Logical Volume.

Logical Volume Capacity and Mapping
ASU-1 (3,044.058 GB)
18 Logical Volumes 169.114 GB per Logical Volume (169.114 GB used per Logical Volume)
ASU-2 (3,044.058 GB)
18 Logical Volumes 169.114 GB per Logical Volume (169.114 GB used per Logical Volume)
ASU-3 (676.457 GB)
2 Logical Volumes 338.229 GB per Logical Volume (338.229 GB used per Logical Volume)

The Data Protection Level used for all Logical Volumes was [Protected 2](#) using *Mirroring* as described on page [12](#). See “ASU Configuration” in the [IOPS Test Results File](#) for more detailed configuration information.

SPC-1 BENCHMARK EXECUTION RESULTS

This portion of the Full Disclosure Report documents the results of the various SPC-1 Tests, Test Phases, and Test Runs. An [SPC-1 glossary](#) on page 67 contains definitions of terms specific to the SPC-1 Tests, Test Phases, and Test Runs.

Clause 5.4.3

The Tests must be executed in the following sequence: Primary Metrics, Repeatability, and Data Persistence. That required sequence must be uninterrupted from the start of Primary Metrics to the completion of Persistence Test Run 1. Uninterrupted means the Benchmark Configuration shall not be power cycled, restarted, disturbed, altered, or adjusted during the above measurement sequence. If the required sequence is interrupted other than for the Host System/TSC power cycle between the two Persistence Test Runs, the measurement is invalid.

SPC-1 Tests, Test Phases, and Test Runs

The SPC-1 benchmark consists of the following Tests, Test Phases, and Test Runs:

- **Primary Metrics Test**
 - Sustainability Test Phase and Test Run
 - IOPS Test Phase and Test Run
 - Response Time Ramp Test Phase
 - 95% of IOPS Test Run
 - 90% of IOPS Test Run
 - 80% of IOPS Test Run
 - 50% of IOPS Test Run
 - 10% of IOPS Test Run (LRT)
- **Repeatability Test**
 - Repeatability Test Phase 1
 - 10% of IOPS Test Run (LRT)
 - IOPS Test Run
 - Repeatability Test Phase 2
 - 10% of IOPS Test Run (LRT)
 - IOPS Test Run
- **Data Persistence Test**
 - Data Persistence Test Run 1
 - Data Persistence Test Run 2

Each Test is an atomic unit that must be executed from start to finish before any other Test, Test Phase, or Test Run may be executed.

The results from each Test, Test Phase, and Test Run are listed below along with a more detailed explanation of each component.

“Ramp-Up” Test Runs

Clause 5.3.13

In order to warm-up caches or perform the initial ASU data migration in a multi-tier configuration, a Test Sponsor may perform a series of “Ramp-Up” Test Runs as a substitute for an initial, gradual Ramp-Up.

Clause 5.3.13.3

The “Ramp-Up” Test Runs will immediately precede the Primary Metrics Test as part of the uninterrupted SPC-1 measurement sequence.

Clause 9.4.3.7.1

If a series of “Ramp-Up” Test Runs were included in the SPC-1 measurement sequence, the FDR shall report the duration (ramp-up and measurement interval), BSU level, SPC-1 IOPS and average response time for each “Ramp-Up” Test Run in an appropriate table.

There were no “Ramp-Up” Test Runs executed.

Primary Metrics Test – Sustainability Test Phase

Clause 5.4.4.1.1

The Sustainability Test Phase has exactly one Test Run and shall demonstrate the maximum sustainable I/O Request Throughput within at least a continuous eight (8) hour Measurement Interval. This Test Phase also serves to insure that the TSC has reached Steady State prior to reporting the final maximum I/O Request Throughput result (SPC-1 IOPS™).

Clause 5.4.4.1.2

The computed I/O Request Throughput of the Sustainability Test must be within 5% of the reported SPC-1 IOPS™ result.

Clause 5.4.4.1.4

The Average Response Time, as defined in Clause 5.1.1, will be computed and reported for the Sustainability Test Run and cannot exceed 30 milliseconds. If the Average Response time exceeds that 30-milliseconds constraint, the measurement is invalid.

Clause 9.4.3.7.2

For the Sustainability Test Phase the FDR shall contain:

- 1. A Data Rate Distribution graph and data table.*
- 2. I/O Request Throughput Distribution graph and data table.*
- 3. A Response Time Frequency Distribution graph and table.*
- 4. An Average Response Time Distribution graph and table.*
- 5. The human readable Test Run Results File produced by the Workload Generator (may be included in an appendix).*
- 6. A listing or screen image of all input parameters supplied to the Workload Generator (may be included in an appendix).*
- 7. The Measured Intensity Multiplier for each I/O stream.*
- 8. The variability of the Measured Intensity Multiplier, as defined in Clause 5.3.13.3.*

SPC-1 Workload Generator Input Parameters

The SPC-1 Workload Generator input parameters for the Sustainability, IOPS, Response Time Ramp, Repeatability, and Persistence Test Runs are documented in [Appendix E: SPC-1 Workload Generator Input Parameters](#) on Page 80.

Sustainability Test Results File

A link to the test results file generated from the Sustainability Test Run is listed below.

[Sustainability Test Results File](#)

Sustainability – Data Rate Distribution Data (MB/second)

The Sustainability Data Rate table of data is not embedded in this document due to its size. The table is available via the following URL:

[Sustainability Data Rate Table](#)

Sustainability – Data Rate Distribution Graph

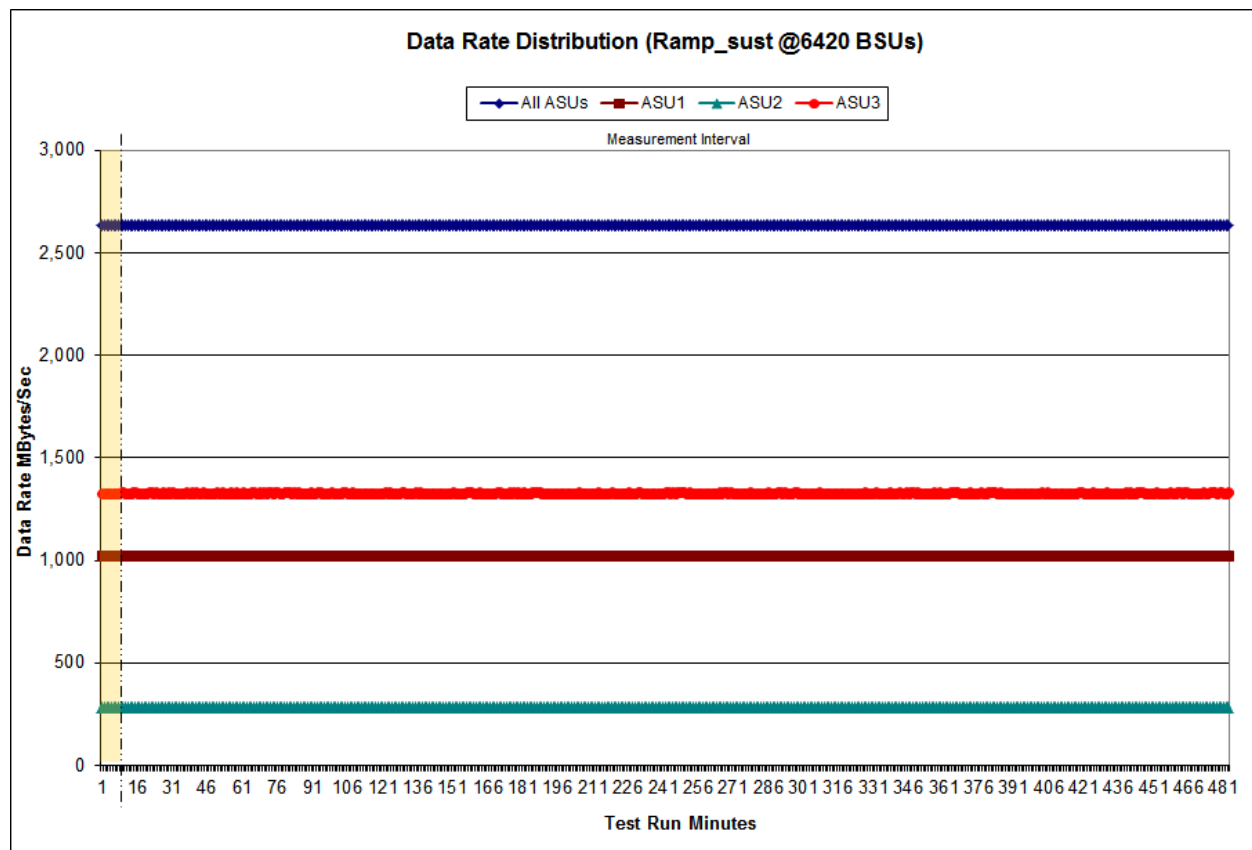

Sustainability – I/O Request Throughput Distribution Data

The Sustainability I/O Request Throughput table of data is not embedded in this document due to its size. The table is available via the following URL:

[Sustainability I/O Request Throughput Table](#)

Sustainability – I/O Request Throughput Distribution Graph

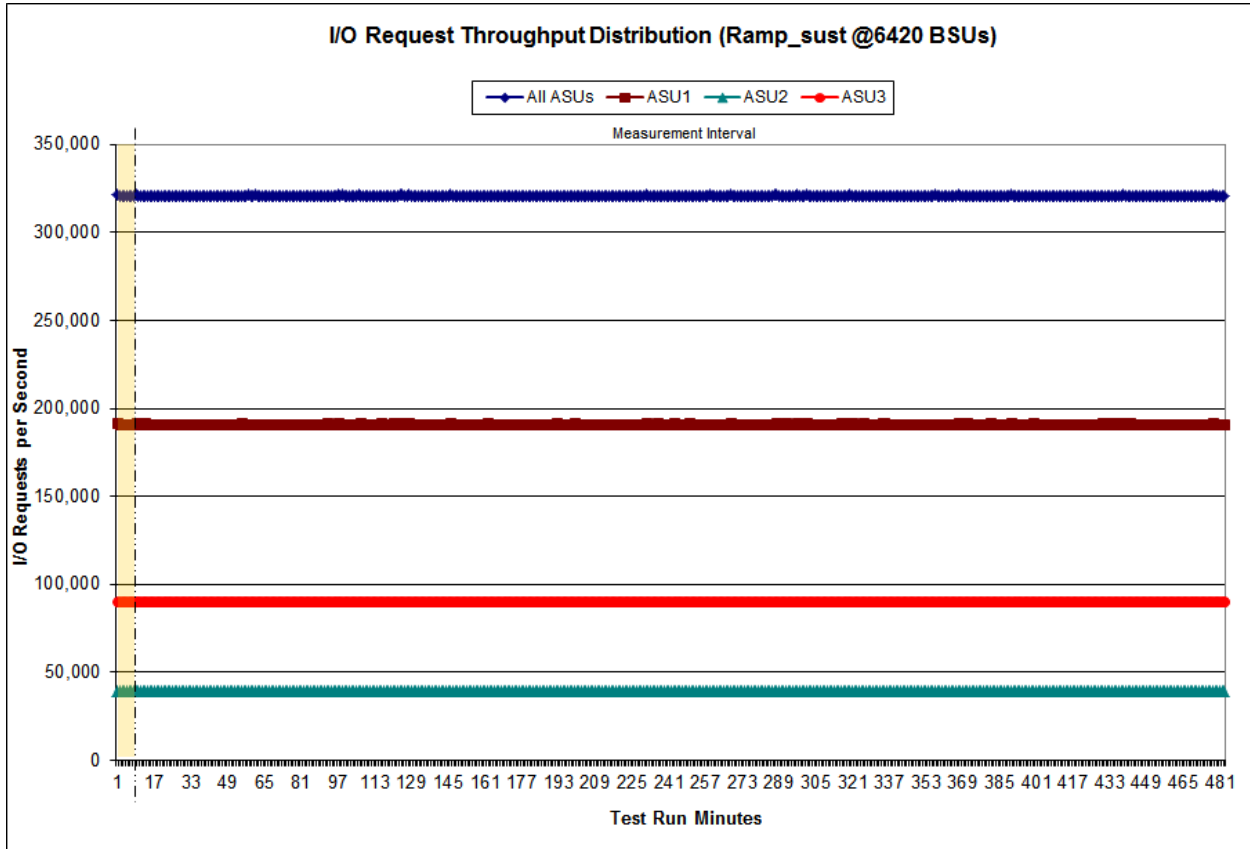

Sustainability – Average Response Time (ms) Distribution Data

The Sustainability Average Response Time table of data is not embedded in this document due to its size. The table is available via the following URL:

[Sustainability Average Response Time Table](#)

Sustainability – Average Response Time (ms) Distribution Graph

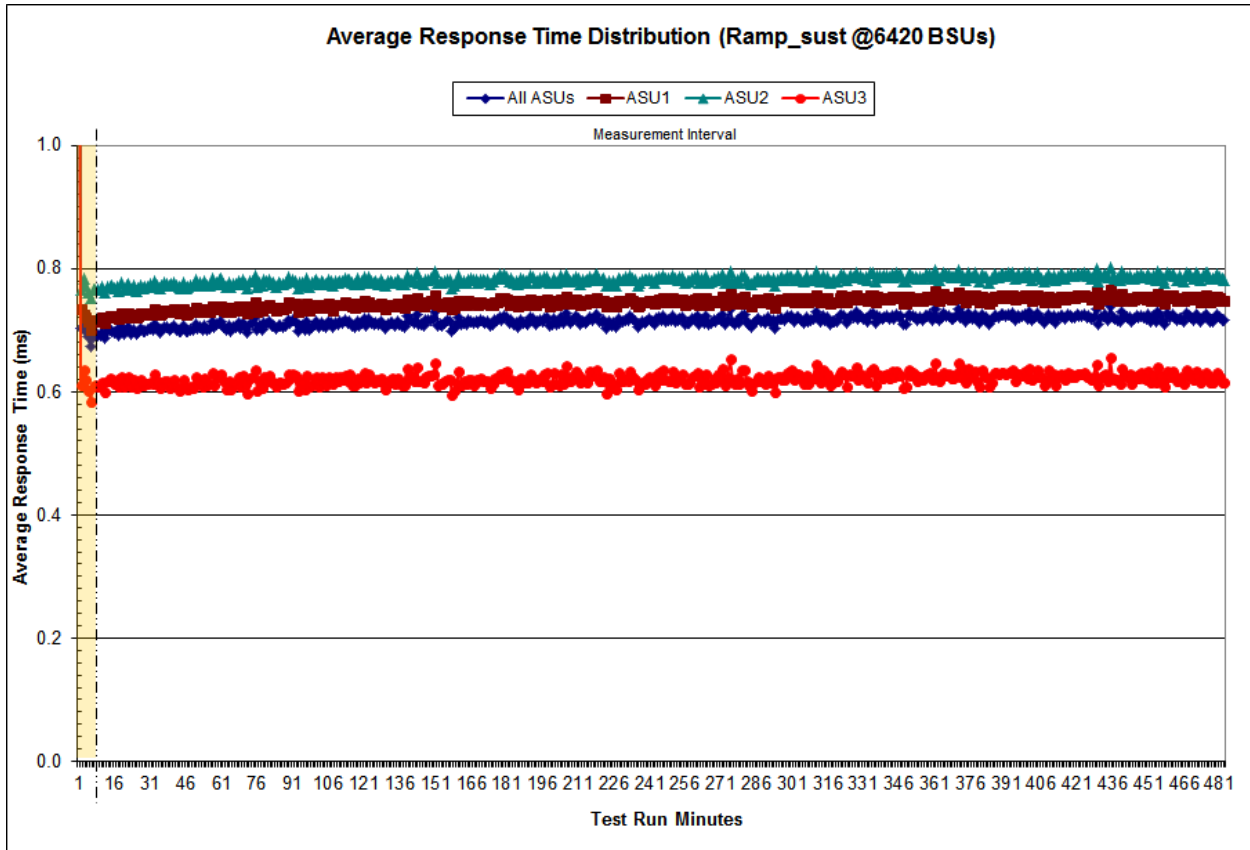

Sustainability – Response Time Frequency Distribution Data

Response Time (ms)	0-0.25	>0.25-0.5	>0.5-0.75	>0.75-1.0	>1.0-1.25	>1.25-1.5	>1.5-1.75	>1.75-2.0
Read	258,151,701	1,900,128,360	639,300,728	167,477,462	95,137,270	68,973,714	56,732,847	50,165,638
Write	60,370,708	3,877,745,685	1,168,768,870	251,405,873	80,733,483	34,720,045	18,506,336	11,461,725
All ASUs	318,522,409	5,777,874,045	1,808,069,598	418,883,335	175,870,753	103,693,759	75,239,183	61,627,363
ASU1	273,644,851	3,356,546,876	980,993,219	239,305,203	112,019,739	71,524,289	54,691,003	46,281,973
ASU2	18,255,463	680,435,371	241,085,750	55,045,151	24,270,466	15,258,017	11,540,419	9,743,488
ASU3	26,622,095	1,740,891,798	585,990,629	124,532,981	39,580,548	16,911,453	9,007,761	5,601,902

Response Time (ms)	>2.0-2.5	>2.5-3.0	>3.0-3.5	>3.5-4.0	>4.0-4.5	>4.5-5.0	>5.0-6.0	>6.0-7.0
Read	89,353,264	79,784,469	63,283,008	48,494,587	37,214,921	27,511,643	33,563,692	16,315,109
Write	13,902,262	9,014,813	6,895,721	5,630,993	4,463,030	3,695,568	6,098,564	5,030,063
All ASUs	103,255,526	88,799,282	70,178,729	54,125,580	41,677,951	31,207,211	39,662,256	21,345,172
ASU1	79,567,979	69,362,795	54,752,636	42,099,761	32,256,294	23,915,163	29,637,034	15,095,982
ASU2	16,821,489	14,902,047	11,887,688	9,079,640	7,024,472	5,262,730	6,604,636	3,411,740
ASU3	6,866,058	4,534,440	3,538,405	2,946,179	2,397,185	2,029,318	3,420,586	2,837,450

Response Time (ms)	>7.0-8.0	>8.0-9.0	>9.0-10.0	>10.0-15.0	>15.0-20.0	>20.0-25.0	>25.0-30.0	>30.0
Read	7,531,933	3,353,815	1,449,212	1,403,510	529,732	129,778	8,285	4,438
Write	4,292,972	3,799,591	3,331,009	12,833,576	10,947,886	2,613,708	1,139,001	1,346,136
All ASUs	11,824,905	7,153,406	4,780,221	14,237,086	11,477,618	2,743,486	1,147,286	1,350,574
ASU1	7,688,519	4,154,899	2,477,673	6,482,846	5,119,368	1,209,696	487,560	570,560
ASU2	1,757,712	959,033	573,794	1,499,312	1,181,519	281,244	113,775	133,098
ASU3	2,378,674	2,039,474	1,728,754	6,254,928	5,176,731	1,252,546	545,951	646,916

Sustainability – Response Time Frequency Distribution Graph

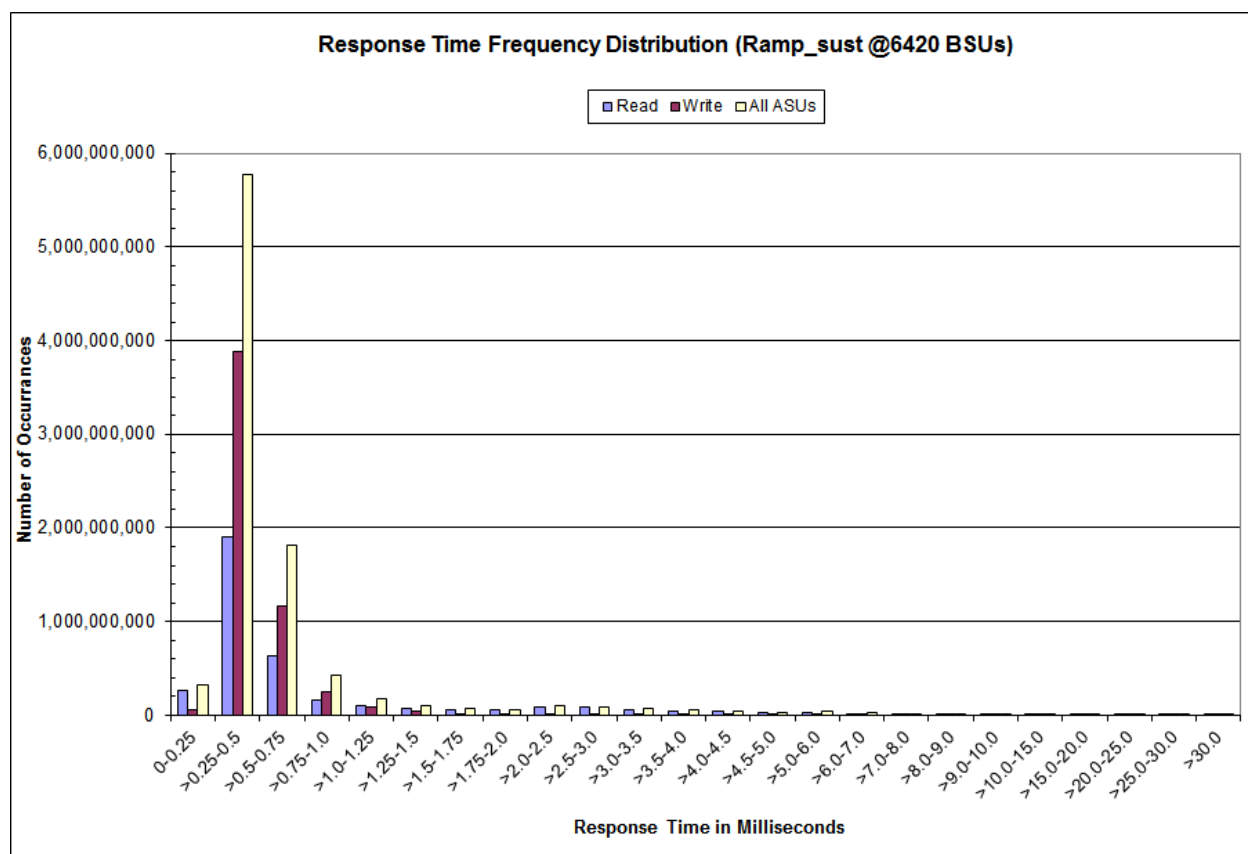

Sustainability – Measured Intensity Multiplier and Coefficient of Variation

Clause 3.4.3

IM – Intensity Multiplier: The ratio of I/Os for each I/O stream relative to the total I/Os for all I/O streams (ASU1-1 – ASU3-1) as required by the benchmark specification.

Clauses 5.1.10 and 5.3.15.2

MIM – Measured Intensity Multiplier: The Measured Intensity Multiplier represents the ratio of measured I/Os for each I/O stream relative to the total I/Os measured for all I/O streams (ASU1-1 – ASU3-1). This value may differ from the corresponding Expected Intensity Multiplier by no more than 5%.

Clause 5.3.15.3

COV – Coefficient of Variation: This measure of variation for the Measured Intensity Multiplier cannot exceed 0.2.

	ASU1-1	ASU1-2	ASU1-3	ASU1-4	ASU2-1	ASU2-2	ASU2-3	ASU3-1
IM	0.0350	0.2810	0.0700	0.2100	0.0180	0.0700	0.0350	0.2810
MIM	0.0350	0.2810	0.0700	0.2100	0.0180	0.0700	0.0350	0.2810
COV	0.001	0.000	0.001	0.000	0.002	0.001	0.001	0.000

Primary Metrics Test – IOPS Test Phase

Clause 5.4.4.2

The IOPS Test Phase consists of one Test Run at the 100% load point with a Measurement Interval of ten (10) minutes. The IOPS Test Phase immediately follows the Sustainability Test Phase without any interruption or manual intervention.

The IOPS Test Run generates the SPC-1 IOPS™ primary metric, which is computed as the I/O Request Throughput for the Measurement Interval of the IOPS Test Run.

The Average Response Time is computed for the IOPS Test Run and cannot exceed 30 milliseconds. If the Average Response Time exceeds the 30 millisecond constraint, the measurement is invalid.

Clause 9.4.3.7.3

For the IOPS Test Phase the FDR shall contain:

- 1. I/O Request Throughput Distribution (data and graph).*
- 2. A Response Time Frequency Distribution.*
- 3. An Average Response Time Distribution.*
- 4. The human readable Test Run Results File produced by the Workload Generator.*
- 5. A listing or screen image of all input parameters supplied to the Workload Generator.*
- 6. The total number of I/O Requests completed in the Measurement Interval as well as the number of I/O Requests with a Response Time less than or equal to 30 milliseconds and the number of I/O Requests with a Response Time greater than 30 milliseconds.*

SPC-1 Workload Generator Input Parameters

The SPC-1 Workload Generator input parameters for the Sustainability, IOPS, Response Time Ramp, Repeatability, and Persistence Test Runs are documented in [Appendix E: SPC-1 Workload Generator Input Parameters](#) on Page [80](#).

IOPS Test Results File

A link to the test results file generated from the IOPS Test Run is listed below.

[IOPS Test Results File](#)

IOPS Test Run – I/O Request Throughput Distribution Data

6,420 BSUs	Start	Stop	Interval	Duration
<i>Start-Up/Ramp-Up</i>	8:49:28	8:52:29	0-2	0:03:01
<i>Measurement Interval</i>	8:52:29	9:02:29	3-12	0:10:00
60 second intervals	All ASUs	ASU1	ASU2	ASU3
0	321,027.40	191,282.02	39,508.13	90,237.25
1	321,185.65	191,441.15	39,477.03	90,267.47
2	321,033.77	191,323.67	39,499.47	90,210.63
3	320,901.08	191,164.22	39,501.82	90,235.05
4	320,795.60	191,213.35	39,435.17	90,147.08
5	321,199.50	191,461.20	39,538.82	90,199.48
6	320,974.08	191,334.27	39,506.50	90,133.32
7	321,003.18	191,380.70	39,478.65	90,143.83
8	320,923.88	191,260.72	39,451.90	90,211.27
9	320,921.58	191,296.77	39,442.67	90,182.15
10	321,058.72	191,333.30	39,517.62	90,207.80
11	321,048.52	191,319.20	39,531.32	90,198.00
12	321,013.92	191,322.93	39,480.88	90,210.10
Average	320,984.01	191,308.67	39,488.53	90,186.81

IOPS Test Run – I/O Request Throughput Distribution Graph

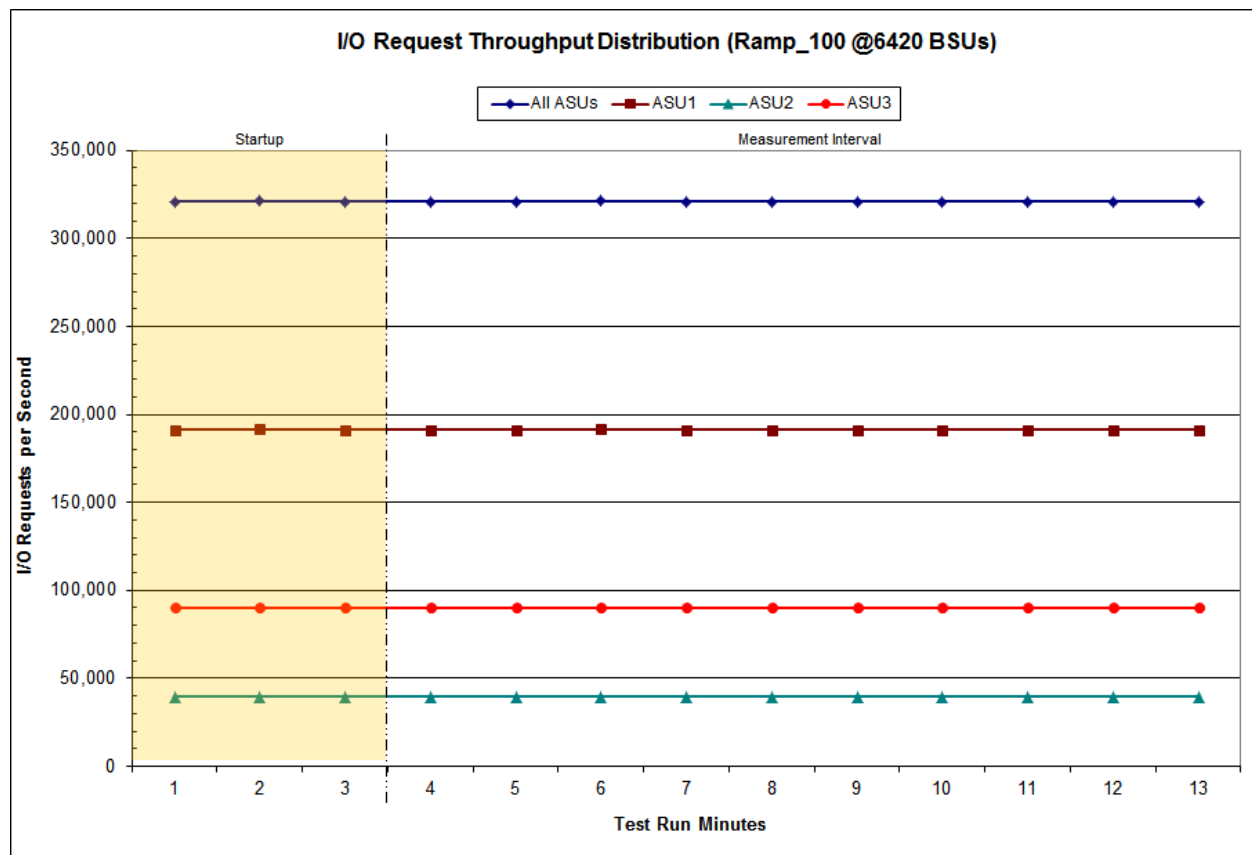

IOPS Test Run – Average Response Time (ms) Distribution Data

6,420 BSUs	Start	Stop	Interval	Duration
<i>Start-Up/Ramp-Up</i>	8:49:28	8:52:29	0-2	0:03:01
<i>Measurement Interval</i>	8:52:29	9:02:29	3-12	0:10:00
60 second intervals	All ASUs	ASU1	ASU2	ASU3
0	0.70	0.73	0.76	0.61
1	0.71	0.74	0.77	0.63
2	0.69	0.71	0.77	0.61
3	0.70	0.72	0.77	0.62
4	0.69	0.72	0.77	0.61
5	0.69	0.71	0.77	0.60
6	0.69	0.71	0.77	0.61
7	0.70	0.72	0.77	0.62
8	0.69	0.71	0.77	0.60
9	0.69	0.72	0.77	0.61
10	0.70	0.72	0.77	0.61
11	0.70	0.72	0.77	0.61
12	0.69	0.72	0.77	0.61
Average	0.69	0.72	0.77	0.61

IOPS Test Run – Average Response Time (ms) Distribution Graph

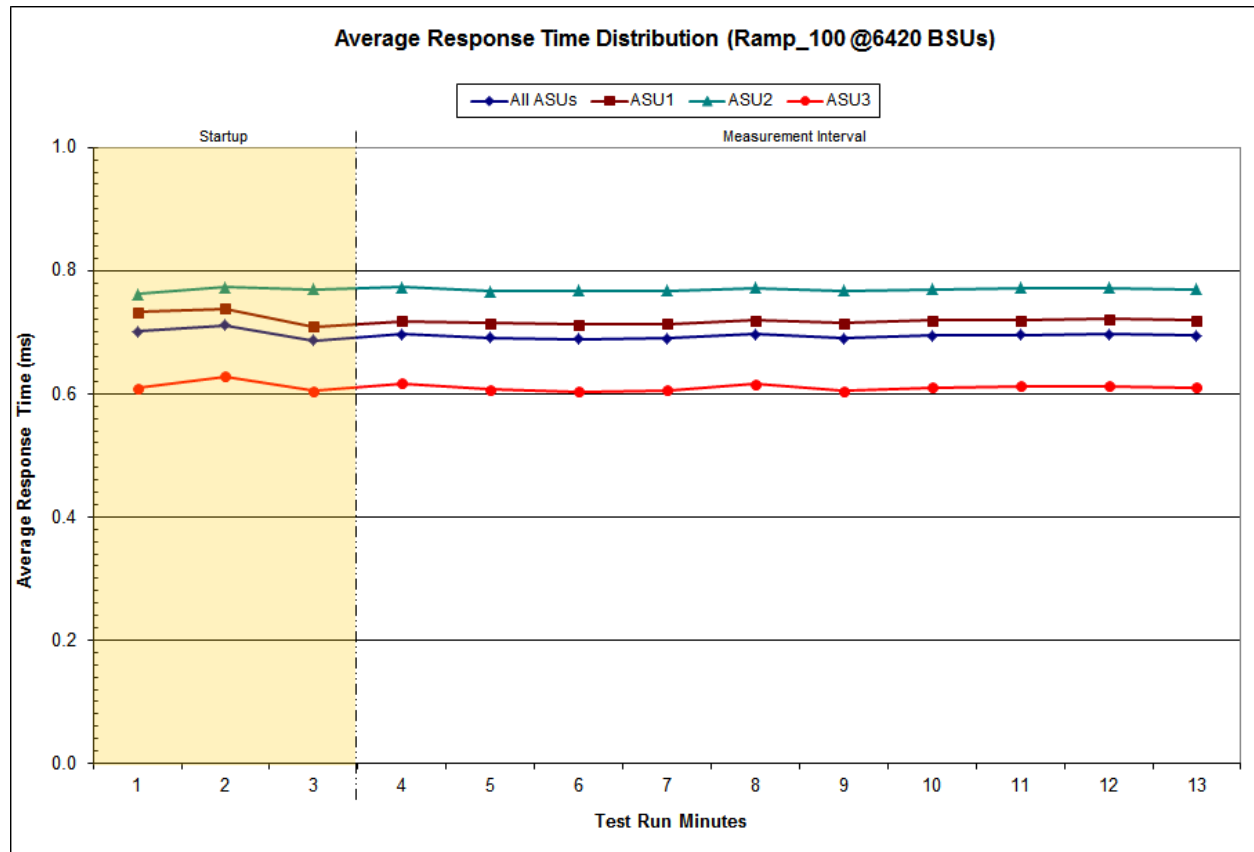

IOPS Test Run –Response Time Frequency Distribution Data

Response Time (ms)	0-0.25	>0.25-0.5	>0.5-0.75	>0.75-1.0	>1.0-1.25	>1.25-1.5	>1.5-1.75	>1.75-2.0
Read	7,891,394	39,242,254	12,313,473	3,172,148	1,816,801	1,331,984	1,103,891	984,877
Write	1,439,263	82,657,663	23,299,834	4,761,307	1,467,578	613,553	322,047	197,416
All ASUs	9,330,657	121,899,917	35,613,307	7,933,455	3,284,379	1,945,537	1,425,938	1,182,293
ASU1	8,237,671	70,230,162	19,082,647	4,507,797	2,095,979	1,349,210	1,040,455	890,420
ASU2	459,176	14,508,954	4,812,175	1,061,946	467,653	297,237	228,492	194,741
ASU3	633,810	37,160,801	11,718,485	2,363,712	720,747	299,090	156,991	97,132
Response Time (ms)	>2.0-2.5	>2.5-3.0	>3.0-3.5	>3.5-4.0	>4.0-4.5	>4.5-5.0	>5.0-6.0	>6.0-7.0
Read	1,765,553	1,579,068	1,247,901	957,715	734,779	544,922	662,045	319,790
Write	242,656	163,493	132,388	109,532	87,511	73,220	122,932	102,002
All ASUs	2,008,209	1,742,561	1,380,289	1,067,247	822,290	618,142	784,977	421,792
ASU1	1,547,170	1,356,059	1,069,904	823,647	631,379	470,146	581,086	294,667
ASU2	341,143	303,557	241,860	185,825	143,333	107,559	134,887	69,565
ASU3	119,896	82,945	68,525	57,775	47,578	40,437	69,004	57,560
Response Time (ms)	>7.0-8.0	>8.0-9.0	>9.0-10.0	>10.0-15.0	>15.0-20.0	>20.0-25.0	>25.0-30.0	>30.0
Read	146,488	64,489	27,764	29,600	16,581	2,792	101	70
Write	88,640	76,734	69,103	267,397	231,342	55,800	23,969	28,320
All ASUs	235,128	141,223	96,867	296,997	247,923	58,592	24,070	28,390
ASU1	150,334	80,766	49,310	135,284	112,979	25,833	10,264	11,888
ASU2	35,660	19,115	11,653	31,229	26,182	5,997	2,307	2,839
ASU3	49,134	41,342	35,904	130,484	108,762	26,762	11,499	13,663

IOPS Test Run –Response Time Frequency Distribution Graph

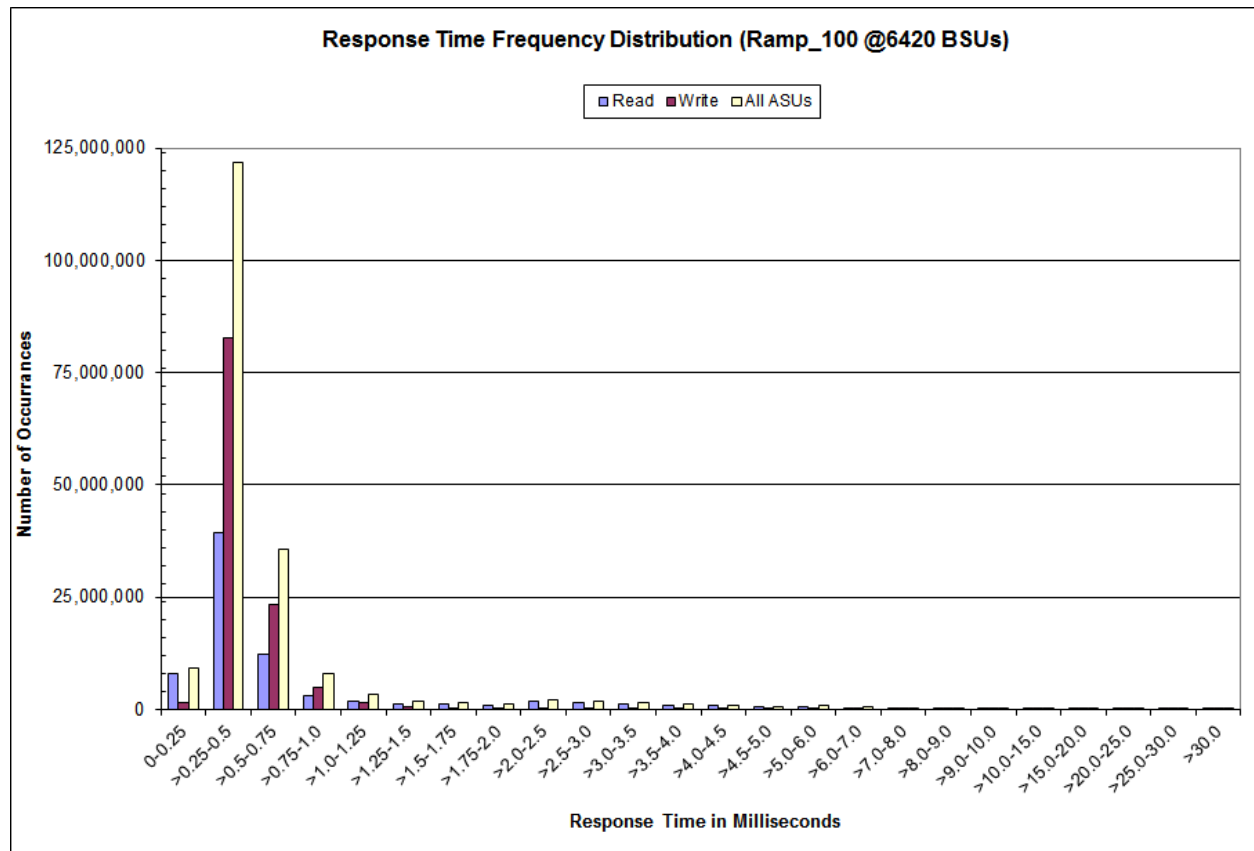

IOPS Test Run – I/O Request Information

I/O Requests Completed in the Measurement Interval
192,590,180
I/O Requests Completed with Response Time = or < 30 ms
192,561,790
I/O Requests Completed with Response Time > 30 ms
28,390

IOPS Test Run – Measured Intensity Multiplier and Coefficient of Variation

Clause 3.4.3

IM – Intensity Multiplier: The ratio of I/Os for each I/O stream relative to the total I/Os for all I/O streams (ASU1-1 – ASU3-1) as required by the benchmark specification.

Clauses 5.1.10 and 5.3.15.2

MIM – Measured Intensity Multiplier: The Measured Intensity Multiplier represents the ratio of measured I/Os for each I/O stream relative to the total I/Os measured for all I/O streams (ASU1-1 – ASU3-1). This value may differ from the corresponding Expected Intensity Multiplier by no more than 5%.

Clause 5.3.15.3

COV – Coefficient of Variation: This measure of variation for the Measured Intensity Multiplier cannot exceed 0.2.

	ASU1-1	ASU1-2	ASU1-3	ASU1-4	ASU2-1	ASU2-2	ASU2-3	ASU3-1
IM	0.0350	0.2810	0.0700	0.2100	0.0180	0.0700	0.0350	0.2810
MIM	0.0350	0.2810	0.0700	0.2100	0.0180	0.07000	0.0350	0.2810
COV	0.002	0.000	0.001	0.001	0.002	0.001	0.001	0.000

Primary Metrics Test – Response Time Ramp Test Phase

Clause 5.4.4.3

The Response Time Ramp Test Phase consists of five Test Runs, one each at 95%, 90%, 80%, 50%, and 10% of the load point (100%) used to generate the SPC-1 IOPS™ primary metric. Each of the five Test Runs has a Measurement Interval of ten (10) minutes. The Response Time Ramp Test Phase immediately follows the IOPS Test Phase without any interruption or manual intervention.

The five Response Time Ramp Test Runs, in conjunction with the IOPS Test Run (100%), demonstrate the relationship between Average Response Time and I/O Request Throughput for the Tested Storage Configuration (TSC) as illustrated in the response time/throughput curve on page 16.

In addition, the Average Response Time measured during the 10% Test Run is the value for the SPC-1 LRT™ metric. That value represents the Average Response Time of a lightly loaded TSC.

Clause 9.4.3.7.4

The following content shall appear in the FDR for the Response Time Ramp Phase:

- 1. A Response Time Ramp Distribution.*
- 2. The human readable Test Run Results File produced by the Workload Generator for each Test Run within the Response Time Ramp Test Phase.*
- 3. For the 10% Load Level Test Run (SPC-1 LRT™ metric) an Average Response Time Distribution.*
- 4. A listing or screen image of all input parameters supplied to the Workload Generator.*

SPC-1 Workload Generator Input Parameters

The SPC-1 Workload Generator input parameters for the Sustainability, IOPS, Response Time Ramp, Repeatability, and Persistence Test Runs are documented in [Appendix E: SPC-1 Workload Generator Input Parameters](#) on Page [80](#).

Response Time Ramp Test Results File

A link to each test result file generated from each Response Time Ramp Test Run list listed below.

[95% Load Level](#)

[90% Load Level](#)

[80% Load Level](#)

[50% Load Level](#)

[10% Load Level](#)

Response Time Ramp Distribution (IOPS) Data

The five Test Runs that comprise the Response Time Ramp Phase are executed at 95%, 90%, 80%, 50%, and 10% of the Business Scaling Unit (BSU) load level used to produce the SPC-1 IOPS™ primary metric. The 100% BSU load level is included in the following Response Time Ramp data table and graph for completeness.

100% Load Level: 6,420 BSUs					95% Load Level: 6,099 BSUs				
	Start	Stop	Interval	Duration		Start	Stop	Interval	Duration
Start-Up/Ramp-Up	8:49:28	8:52:29	0-3	0:03:01	Start-Up/Ramp-Up	9:02:58	9:05:59	0-3	0:03:01
Measurement Interval	8:52:29	9:02:29	3-12	0:10:00	Measurement Interval	9:05:59	9:15:59	3-12	0:10:00
(60 second intervals)	All ASUs	ASU-1	ASU-2	ASU-3	(60 second intervals)	All ASUs	ASU-1	ASU-2	ASU-3
0	321,027.40	191,282.02	39,508.13	90,237.25	0	304,990.95	181,787.72	37,516.85	85,686.38
1	321,185.65	191,441.15	39,477.03	90,267.47	1	304,909.72	181,723.95	37,487.08	85,698.68
2	321,033.77	191,323.67	39,499.47	90,210.63	2	305,023.85	181,802.82	37,528.27	85,692.77
3	320,901.08	191,164.22	39,501.82	90,235.05	3	304,860.90	181,722.33	37,482.87	85,655.70
4	320,795.60	191,213.35	39,435.17	90,147.08	4	304,890.02	181,688.25	37,525.90	85,675.87
5	321,199.50	191,461.20	39,538.82	90,199.48	5	304,995.72	181,763.43	37,534.62	85,697.67
6	320,974.08	191,334.27	39,506.50	90,133.32	6	304,980.82	181,749.70	37,511.38	85,719.73
7	321,003.18	191,380.70	39,478.65	90,143.83	7	305,010.98	181,768.78	37,495.18	85,747.02
8	320,923.88	191,260.72	39,451.90	90,211.27	8	304,943.15	181,781.88	37,501.28	85,659.98
9	320,921.58	191,296.77	39,442.67	90,182.15	9	304,929.97	181,769.02	37,528.77	85,632.18
10	321,058.72	191,333.30	39,517.62	90,207.80	10	305,025.12	181,816.72	37,518.35	85,690.05
11	321,048.52	191,319.20	39,531.32	90,198.00	11	304,936.10	181,792.27	37,479.37	85,664.47
12	321,013.92	191,322.93	39,480.88	90,210.10	12	305,051.22	181,763.70	37,551.48	85,736.03
Average	320,984.01	191,308.67	39,488.53	90,186.81	Average	304,962.40	181,761.61	37,512.92	85,687.87
90% Load Level: 5,778 BSUs					80% Load Level: 5,136 BSUs				
	Start	Stop	Interval	Duration		Start	Stop	Interval	Duration
Start-Up/Ramp-Up	9:16:26	9:19:27	0-3	0:03:01	Start-Up/Ramp-Up	9:29:51	9:32:52	0-3	0:03:01
Measurement Interval	9:19:27	9:29:27	3-12	0:10:00	Measurement Interval	9:32:52	9:42:52	3-12	0:10:00
(60 second intervals)	All ASUs	ASU-1	ASU-2	ASU-3	(60 second intervals)	All ASUs	ASU-1	ASU-2	ASU-3
0	288,927.98	172,179.65	35,522.12	81,226.22	0	256,862.15	153,127.93	31,572.62	72,161.60
1	288,968.45	172,220.82	35,538.85	81,208.78	1	256,761.02	152,993.42	31,556.63	72,210.97
2	288,780.23	172,084.58	35,515.23	81,180.42	2	256,858.90	153,037.12	31,628.58	72,193.20
3	288,936.82	172,247.85	35,500.37	81,188.60	3	256,796.48	153,096.73	31,585.25	72,114.50
4	288,951.82	172,168.17	35,541.43	81,242.22	4	256,679.67	152,978.72	31,590.95	72,110.00
5	288,921.78	172,237.05	35,499.72	81,185.02	5	256,815.13	153,072.55	31,579.08	72,163.50
6	288,766.87	172,068.05	35,531.97	81,166.85	6	256,712.13	152,981.90	31,590.72	72,139.52
7	288,876.40	172,176.62	35,533.32	81,166.47	7	256,833.77	153,128.73	31,579.83	72,125.20
8	288,861.67	172,149.08	35,515.25	81,197.33	8	256,806.82	153,043.67	31,580.90	72,182.25
9	288,986.60	172,267.00	35,528.88	81,190.72	9	256,860.80	153,063.62	31,623.20	72,173.98
10	288,901.12	172,152.92	35,531.57	81,216.63	10	256,738.68	153,028.90	31,554.72	72,155.07
11	288,937.67	172,257.27	35,519.02	81,161.38	11	256,809.77	153,088.58	31,603.67	72,117.52
12	288,936.12	172,153.20	35,545.45	81,237.47	12	256,816.17	153,058.17	31,596.57	72,161.43
Average	288,907.69	172,187.72	35,524.70	81,195.27	Average	256,786.94	153,054.16	31,588.49	72,144.30

Response Time Ramp Distribution (IOPS) Data (continued)

50% Load Level: 3,210 BSUs					10% Load Level: 642 BSUs				
Start-Up/Ramp-Up Measurement Interval	Start	Stop	Interval	Duration	Start-Up/Ramp-Up Measurement Interval	Start	Stop	Interval	Duration
(60 second intervals)	All ASUs	ASU-1	ASU-2	ASU-3	(60 second intervals)	All ASUs	ASU-1	ASU-2	ASU-3
0	160,520.72	95,717.98	19,742.25	45,060.48	0	32,113.82	19,141.58	3,942.47	9,029.77
1	160,504.93	95,668.68	19,744.55	45,091.70	1	32,099.50	19,126.98	3,938.65	9,033.87
2	160,455.85	95,614.20	19,775.78	45,065.87	2	32,131.13	19,166.67	3,945.22	9,019.25
3	160,526.18	95,712.83	19,742.65	45,070.70	3	32,069.50	19,122.73	3,939.47	9,007.30
4	160,542.27	95,660.07	19,740.17	45,142.03	4	32,121.18	19,151.95	3,953.58	9,015.65
5	160,545.97	95,657.00	19,770.73	45,118.23	5	32,100.27	19,126.02	3,946.40	9,027.85
6	160,536.60	95,666.30	19,737.00	45,133.30	6	32,104.40	19,136.72	3,942.88	9,024.80
7	160,535.08	95,657.65	19,743.75	45,133.68	7	32,124.05	19,139.97	3,939.85	9,044.23
8	160,429.23	95,576.92	19,772.65	45,079.67	8	32,101.25	19,123.52	3,955.65	9,022.08
9	160,433.03	95,598.28	19,734.78	45,099.97	9	32,135.67	19,149.97	3,955.93	9,029.77
10	160,415.52	95,588.90	19,749.43	45,077.18	10	32,116.00	19,144.55	3,951.23	9,020.22
11	160,493.15	95,639.02	19,747.17	45,106.97	11	32,090.83	19,112.12	3,951.60	9,027.12
12	160,492.70	95,647.40	19,740.78	45,104.52	12	32,096.20	19,141.80	3,939.92	9,014.48
Average	160,494.97	95,640.44	19,747.91	45,106.63	Average	32,105.94	19,134.93	3,947.65	9,023.35

Response Time Ramp Distribution (IOPS) Graph

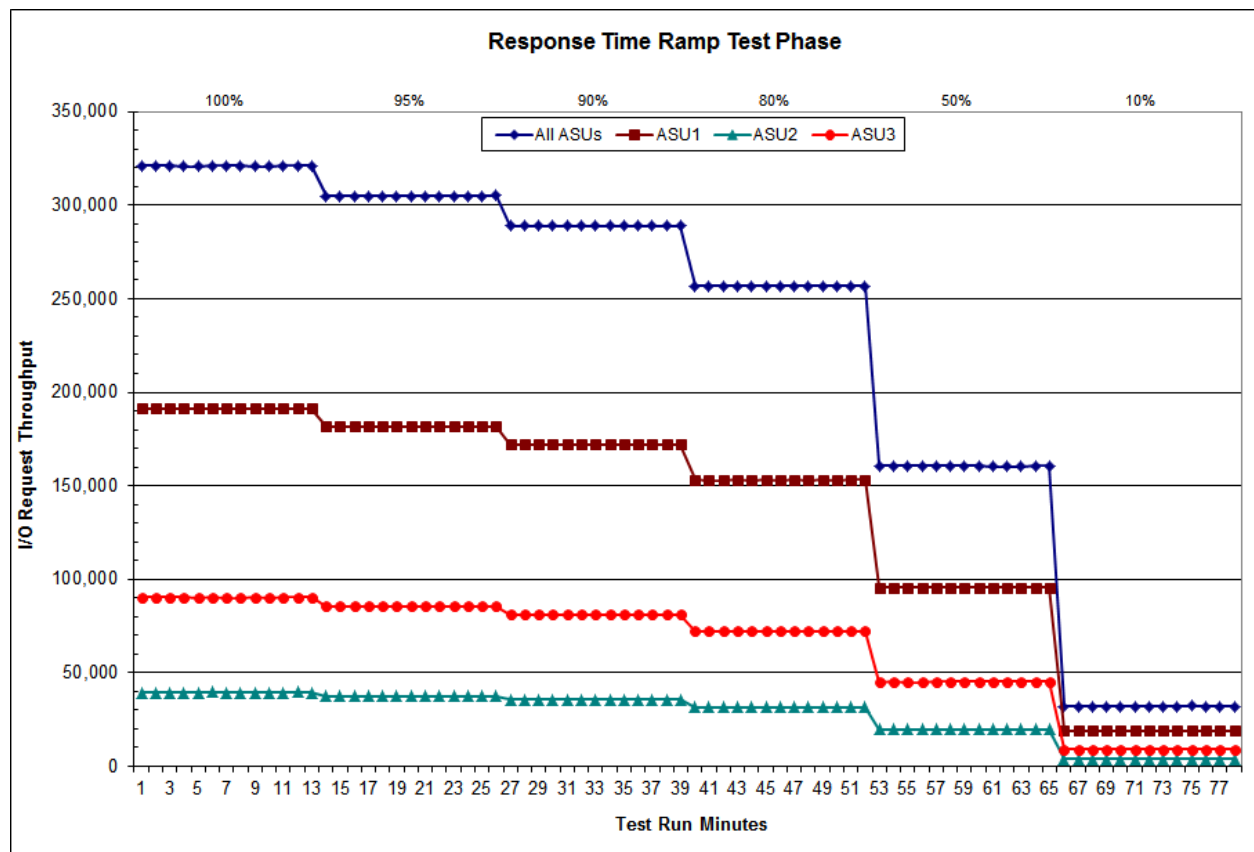

SPC-1 LRT™ Average Response Time (ms) Distribution Data

642 BSUs	Start	Stop	Interval	Duration
Start-Up/Ramp-Up	9:56:20	9:59:21	0-2	0:03:01
Measurement Interval	9:59:21	10:09:21	3-12	0:10:00
60 second intervals	All ASUs	ASU1	ASU2	ASU3
0	0.38	0.38	0.40	0.38
1	0.39	0.38	0.40	0.39
2	0.38	0.37	0.40	0.39
3	0.38	0.37	0.40	0.39
4	0.37	0.36	0.40	0.39
5	0.37	0.36	0.40	0.39
6	0.37	0.36	0.40	0.39
7	0.38	0.36	0.41	0.39
8	0.37	0.36	0.40	0.39
9	0.37	0.35	0.40	0.39
10	0.37	0.36	0.40	0.39
11	0.37	0.35	0.39	0.38
12	0.37	0.36	0.40	0.39
Average	0.37	0.36	0.40	0.39

SPC-1 LRT™ Average Response Time (ms) Distribution Graph

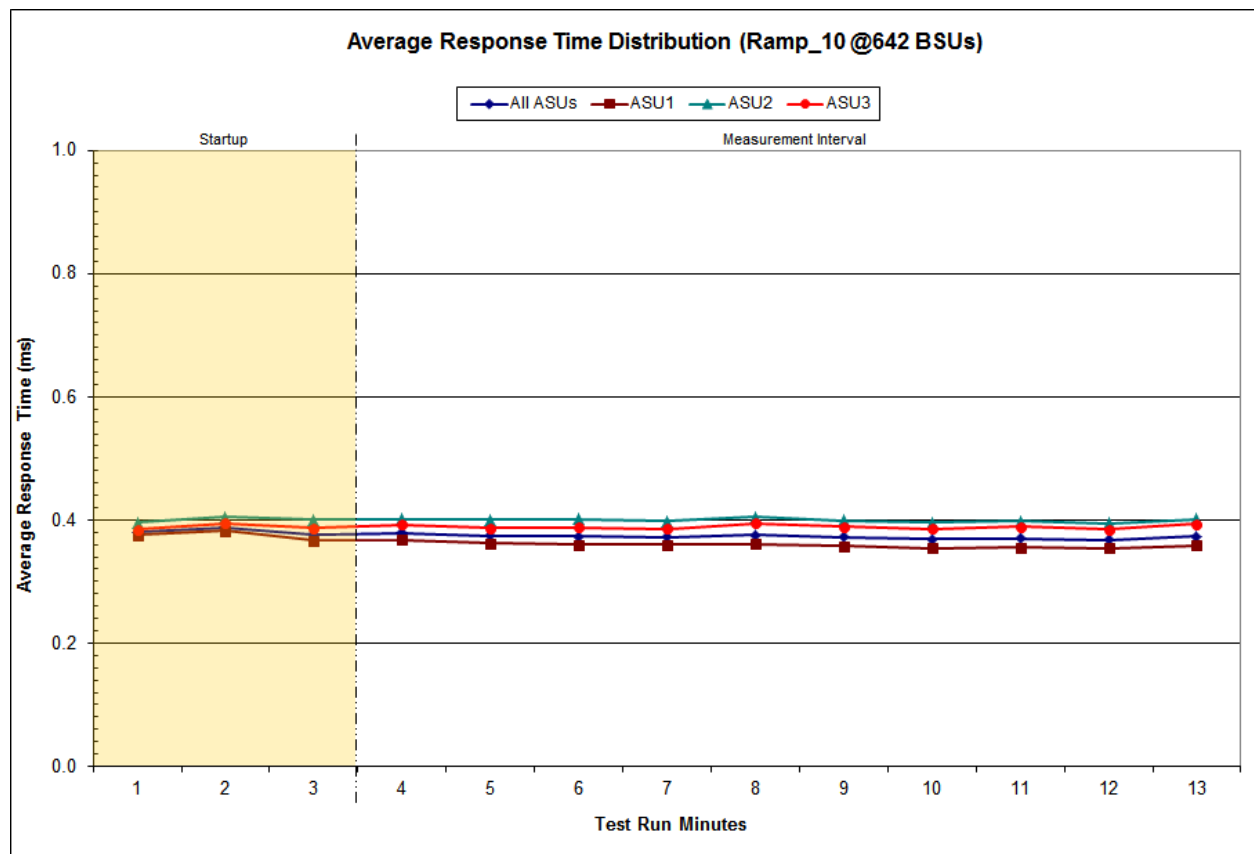

SPC-1 LRT™ (10%) – Measured Intensity Multiplier and Coefficient of Variation

Clause 3.4.3

IM – Intensity Multiplier: The ratio of I/Os for each I/O stream relative to the total I/Os for all I/O streams (ASU1-1 – ASU3-1) as required by the benchmark specification.

Clauses 5.1.10 and 5.3.15.2

MIM – Measured Intensity Multiplier: The Measured Intensity Multiplier represents the ratio of measured I/Os for each I/O stream relative to the total I/Os measured for all I/O streams (ASU1-1 – ASU3-1). This value may differ from the corresponding Expected Intensity Multiplier by no more than 5%.

Clause 5.3.15.3

COV – Coefficient of Variation: This measure of variation for the Measured Intensity Multiplier cannot exceed 0.2.

	ASU1-1	ASU1-2	ASU1-3	ASU1-4	ASU2-1	ASU2-2	ASU2-3	ASU3-1
IM	0.0350	0.2810	0.0700	0.2100	0.0180	0.0700	0.0350	0.2810
MIM	0.0350	0.2810	0.0701	0.2099	0.0179	0.0700	0.0350	0.2810
COV	0.003	0.001	0.003	0.001	0.005	0.001	0.005	0.001

Repeatability Test

Clause 5.4.5

The Repeatability Test demonstrates the repeatability and reproducibility of the SPC-1 IOPS™ primary metric and the SPC-1 LRT™ metric generated in earlier Test Runs.

There are two identical Repeatability Test Phases. Each Test Phase contains two Test Runs. Each of the Test Runs will have a Measurement Interval of no less than ten (10) minutes. The two Test Runs in each Test Phase will be executed without interruption or any type of manual intervention.

The first Test Run in each Test Phase is executed at the 10% load point. The Average Response Time from each of the Test Runs is compared to the SPC-1 LRT™ metric. Each Average Response Time value must be less than the SPC-1 LRT™ metric plus 5% or less than the SPC-1 LRT™ metric plus one (1) millisecond (ms).

The second Test Run in each Test Phase is executed at the 100% load point. The I/O Request Throughput from the Test Runs is compared to the SPC-1 IOPS™ primary metric. Each I/O Request Throughput value must be greater than the SPC-1 IOPS™ primary metric minus 5%. In addition, the Average Response Time for each Test Run cannot exceed 30 milliseconds.

If any of the above constraints are not met, the benchmark measurement is invalid.

Clause 9.4.3.7.5

The following content shall appear in the FDR for each Test Run in the two Repeatability Test Phases:

- 1. A table containing the results of the Repeatability Test.*
- 2. An I/O Request Throughput Distribution graph and table.*
- 3. An Average Response Time Distribution graph and table.*
- 4. The human readable Test Run Results File produced by the Workload Generator.*
- 5. A listing or screen image of all input parameters supplied to the Workload Generator.*

SPC-1 Workload Generator Input Parameters

The SPC-1 Workload Generator input parameters for the Sustainability, IOPS, Response Time Ramp, Repeatability, and Persistence Test Runs are documented in [Appendix E: SPC-1 Workload Generator Input Parameters](#) on Page [80](#).

Repeatability Test Results File

The values for the SPC-1 IOPS™, SPC-1 LRT™, and the Repeatability Test measurements are listed in the tables below.

	SPC-1 IOPS™
Primary Metrics	320,984.01
Repeatability Test Phase 1	321,001.74
Repeatability Test Phase 2	320,992.41

The SPC-1 IOPS™ values in the above table were generated using 100% of the specified Business Scaling Unit (BSU) load level. Each of the Repeatability Test Phase values for SPC-1 IOPS™ must be greater than 95% of the reported SPC-1 IOPS™ Primary Metric.

	SPC-1 LRT™
Primary Metrics	0.37
Repeatability Test Phase 1	0.37
Repeatability Test Phase 2	0.37

The average response time values in the SPC-1 LRT™ column were generated using 10% of the specified Business Scaling Unit (BSU) load level. Each of the Repeatability Test Phase values for SPC-1 LRT™ must be less than 105% of the reported SPC-1 LRT™ Primary Metric or less than the reported SPC-1 LRT™ Primary Metric plus one (1) millisecond (ms).

A link to the test result file generated from each Repeatability Test Run is listed below.

[Repeatability Test Phase 1, Test Run 1 \(LRT\)](#)

[Repeatability Test Phase 1, Test Run 2 \(IOPS\)](#)

[Repeatability Test Phase 2, Test Run 1 \(LRT\)](#)

[Repeatability Test Phase 2, Test Run 2 \(IOPS\)](#)

Repeatability 1 LRT – I/O Request Throughput Distribution Data

642 BSUs	Start	Stop	Interval	Duration
Start-Up/Ramp-Up	10:09:38	10:12:38	0-2	0:03:00
Measurement Interval	10:12:38	10:22:38	3-12	0:10:00
60 second intervals	All ASUs	ASU1	ASU2	ASU3
0	32,106.33	19,130.68	3,942.18	9,033.47
1	32,144.68	19,148.22	3,957.48	9,038.98
2	32,124.22	19,151.02	3,941.75	9,031.45
3	32,113.52	19,144.58	3,961.27	9,007.67
4	32,161.08	19,173.75	3,955.98	9,031.35
5	32,099.10	19,127.43	3,941.12	9,030.55
6	32,089.82	19,146.60	3,941.88	9,001.33
7	32,125.43	19,145.53	3,962.83	9,017.07
8	32,125.97	19,152.68	3,941.58	9,031.70
9	32,102.23	19,139.70	3,942.18	9,020.35
10	32,042.70	19,111.03	3,923.25	9,008.42
11	32,129.45	19,143.35	3,953.88	9,032.22
12	32,102.45	19,135.87	3,950.40	9,016.18
Average	32,109.18	19,142.05	3,947.44	9,019.68

Repeatability 1 LRT – I/O Request Throughput Distribution Graph

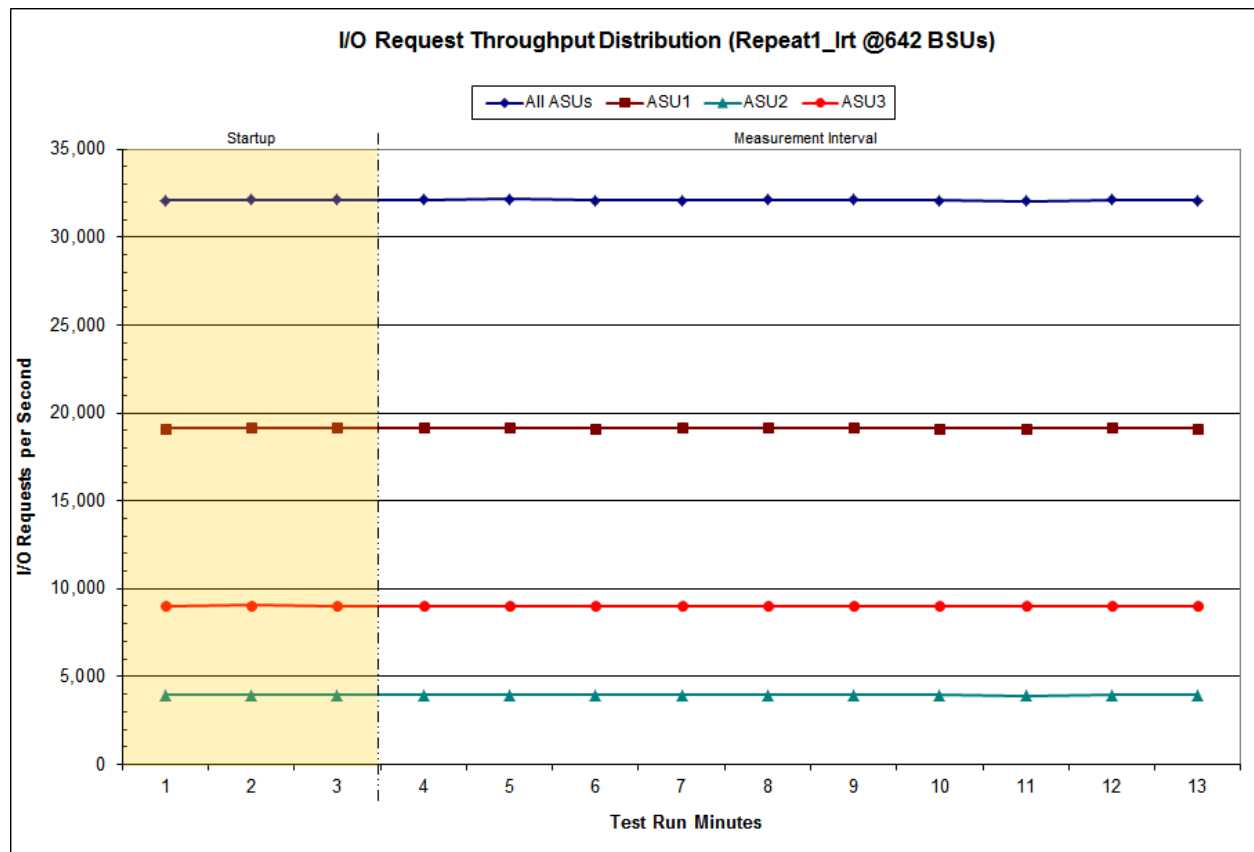

Repeatability 1 LRT –Average Response Time (ms) Distribution Data

642 BSUs	Start	Stop	Interval	Duration
<i>Start-Up/Ramp-Up</i>	10:09:38	10:12:38	0-2	0:03:00
<i>Measurement Interval</i>	10:12:38	10:22:38	3-12	0:10:00
60 second intervals	All ASUs	ASU1	ASU2	ASU3
0	0.38	0.38	0.40	0.39
1	0.38	0.37	0.39	0.38
2	0.38	0.37	0.40	0.39
3	0.37	0.36	0.40	0.38
4	0.37	0.36	0.40	0.38
5	0.37	0.36	0.40	0.39
6	0.38	0.36	0.41	0.40
7	0.37	0.36	0.40	0.38
8	0.37	0.36	0.40	0.39
9	0.37	0.36	0.40	0.39
10	0.37	0.36	0.40	0.39
11	0.37	0.36	0.40	0.39
12	0.37	0.36	0.40	0.39
<i>Average</i>	<i>0.37</i>	<i>0.36</i>	<i>0.40</i>	<i>0.39</i>

Repeatability 1 LRT –Average Response Time (ms) Distribution Graph

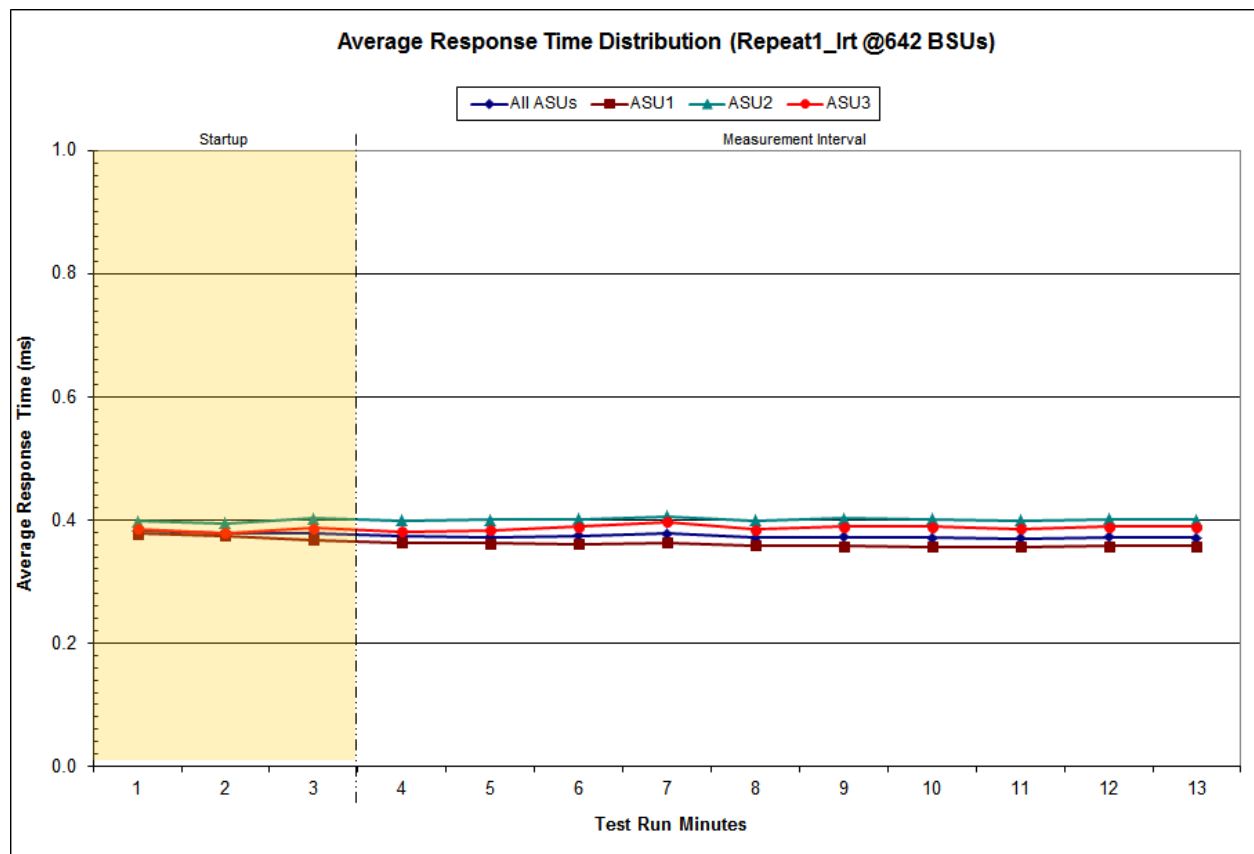

Repeatability 1 IOPS – I/O Request Throughput Distribution Data

6,420 BSUs	Start	Stop	Interval	Duration
<i>Start-Up/Ramp-Up</i>	10:23:11	10:26:12	0-2	0:03:01
<i>Measurement Interval</i>	10:26:12	10:36:12	3-12	0:10:00
60 second intervals	All ASUs	ASU1	ASU2	ASU3
0	321,029.22	191,376.13	39,476.12	90,176.97
1	320,898.82	191,237.48	39,442.58	90,218.75
2	321,024.97	191,345.57	39,515.32	90,164.08
3	321,023.32	191,298.82	39,465.85	90,258.65
4	320,920.08	191,274.18	39,442.73	90,203.17
5	321,069.62	191,294.83	39,502.98	90,271.80
6	320,977.83	191,325.47	39,464.43	90,187.93
7	321,084.48	191,456.75	39,463.88	90,163.85
8	321,039.17	191,290.00	39,529.72	90,219.45
9	320,964.30	191,251.98	39,536.08	90,176.23
10	320,985.03	191,301.03	39,520.27	90,163.73
11	320,988.35	191,349.37	39,458.88	90,180.10
12	320,965.18	191,318.45	39,454.53	90,192.20
Average	321,001.74	191,316.09	39,483.94	90,201.71

Repeatability 1 IOPS – I/O Request Throughput Distribution Graph

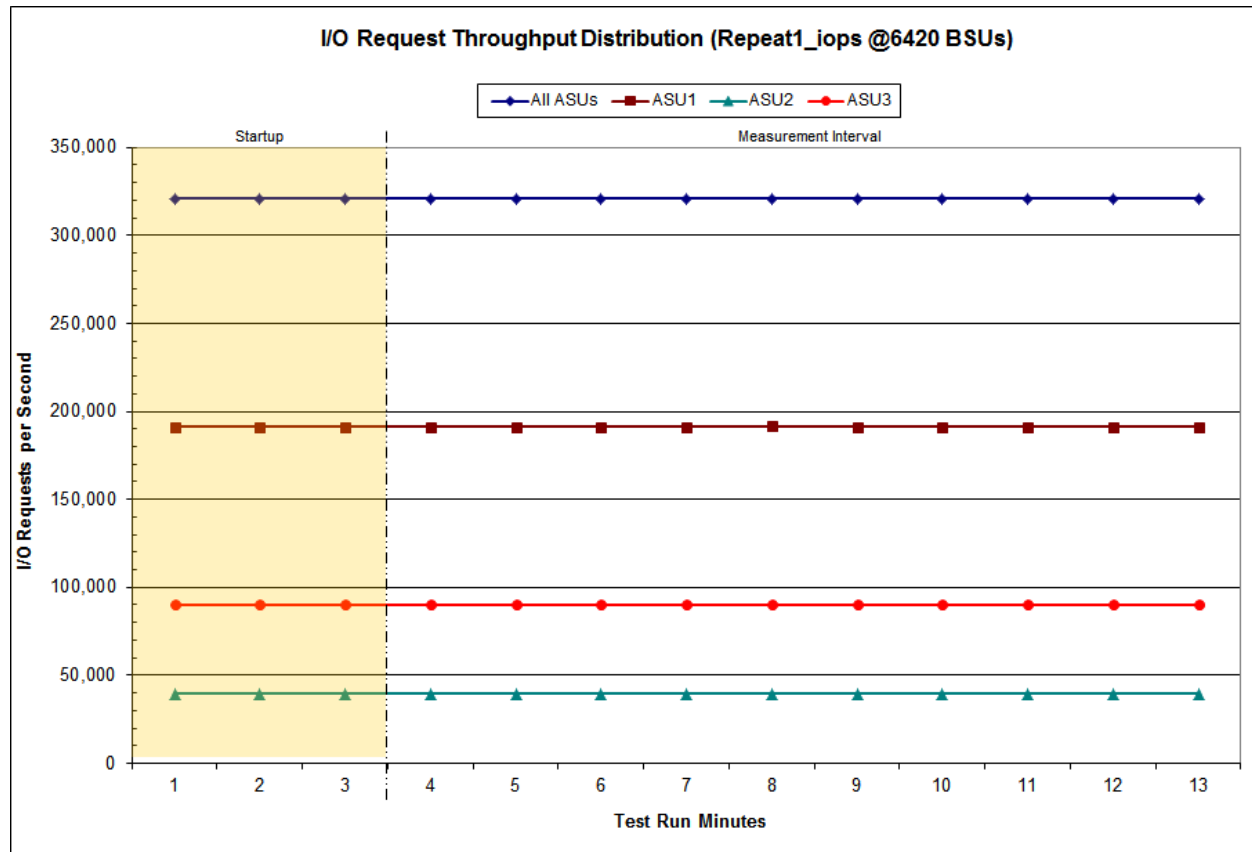

Repeatability 1 IOPS –Average Response Time (ms) Distribution Data

6,420 BSUs Start-Up/Ramp-Up Measurement Interval	Start 10:23:11 10:26:12	Stop 10:26:12 10:36:12	Interval 0-2 3-12	Duration 0:03:01 0:10:00
60 second intervals	All ASUs	ASU1	ASU2	ASU3
0	0.69	0.72	0.75	0.61
1	0.70	0.73	0.76	0.61
2	0.69	0.71	0.77	0.61
3	0.69	0.71	0.77	0.61
4	0.70	0.73	0.78	0.63
5	0.70	0.72	0.77	0.62
6	0.69	0.72	0.77	0.61
7	0.69	0.71	0.76	0.60
8	0.70	0.72	0.77	0.61
9	0.70	0.72	0.77	0.62
10	0.70	0.72	0.77	0.62
11	0.70	0.72	0.77	0.61
12	0.69	0.72	0.77	0.61
Average	0.70	0.72	0.77	0.61

Repeatability 1 IOPS –Average Response Time (ms) Distribution Graph

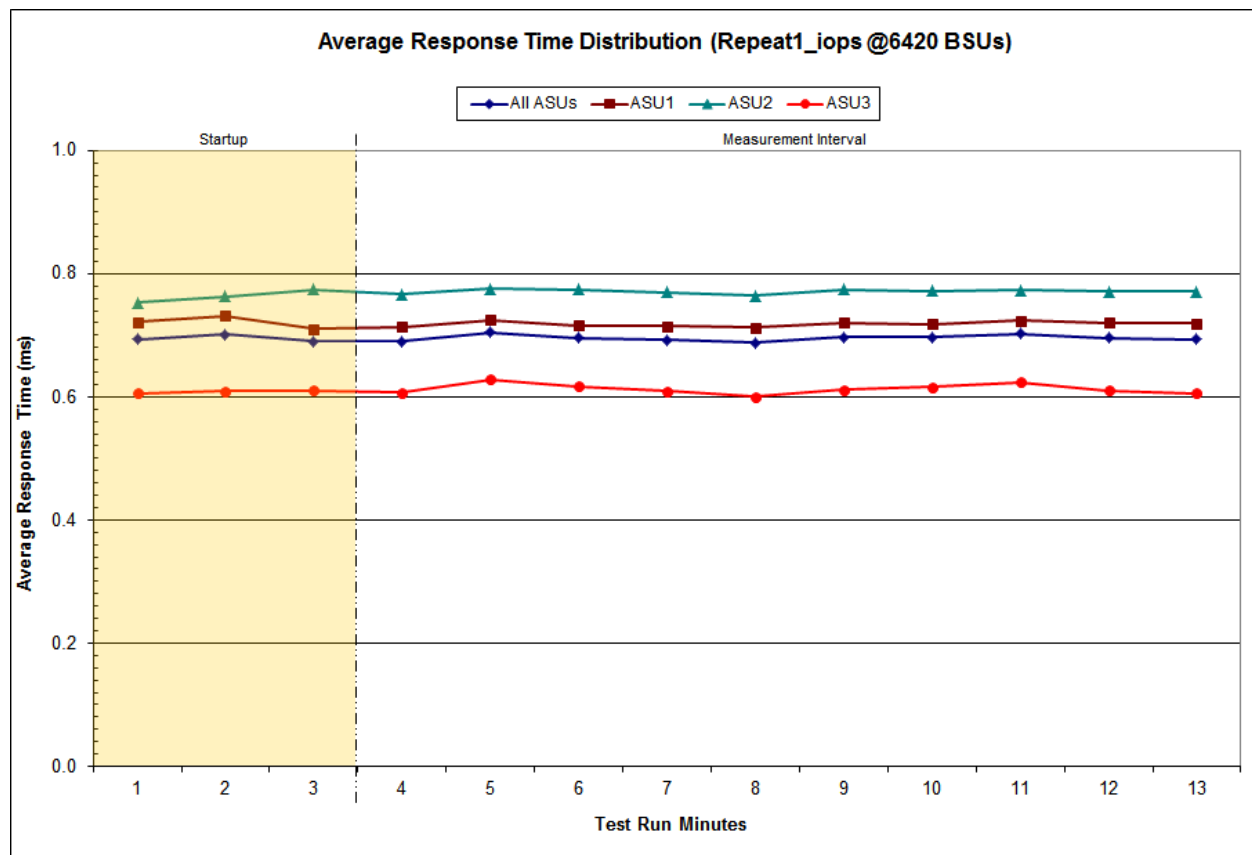

Repeatability 2 LRT – I/O Request Throughput Distribution Data

642 BSUs	Start	Stop	Interval	Duration
<i>Start-Up/Ramp-Up</i>	10:36:27	10:39:27	0-2	0:03:00
<i>Measurement Interval</i>	10:39:27	10:49:27	3-12	0:10:00
60 second intervals	All ASUs	ASU1	ASU2	ASU3
0	32,129.72	19,146.37	3,950.23	9,033.12
1	32,119.12	19,152.20	3,952.07	9,014.85
2	32,115.43	19,126.97	3,946.87	9,041.60
3	32,067.75	19,124.67	3,938.05	9,005.03
4	32,117.75	19,144.40	3,945.67	9,027.68
5	32,096.02	19,122.98	3,952.28	9,020.75
6	32,160.48	19,177.43	3,954.10	9,028.95
7	32,065.02	19,078.58	3,952.78	9,033.65
8	32,105.55	19,141.60	3,942.00	9,021.95
9	32,098.97	19,117.20	3,954.78	9,026.98
10	32,073.28	19,105.22	3,945.97	9,022.10
11	32,092.80	19,134.35	3,947.58	9,010.87
12	32,104.75	19,130.37	3,935.38	9,039.00
Average	32,098.24	19,127.68	3,946.86	9,023.70

Repeatability 2 LRT – I/O Request Throughput Distribution Graph

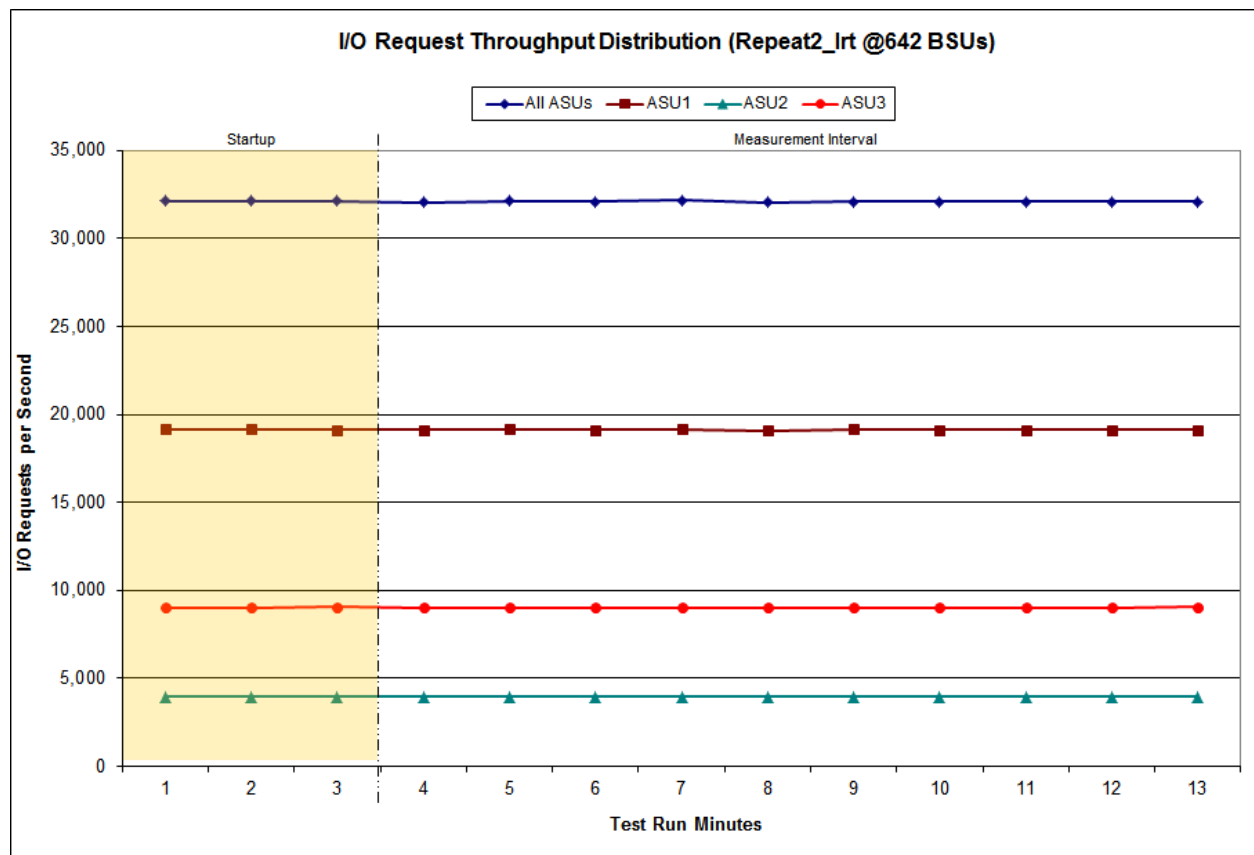

Repeatability 2 LRT –Average Response Time (ms) Distribution Data

642 BSUs	Start	Stop	Interval	Duration
<i>Start-Up/Ramp-Up</i>	10:36:27	10:39:27	0-2	0:03:00
<i>Measurement Interval</i>	10:39:27	10:49:27	3-12	0:10:00
60 second intervals	All ASUs	ASU1	ASU2	ASU3
0	0.38	0.38	0.40	0.39
1	0.38	0.38	0.40	0.39
2	0.38	0.37	0.40	0.39
3	0.37	0.36	0.40	0.39
4	0.37	0.36	0.40	0.38
5	0.37	0.36	0.40	0.39
6	0.37	0.36	0.40	0.39
7	0.37	0.36	0.40	0.39
8	0.37	0.36	0.40	0.39
9	0.37	0.36	0.40	0.39
10	0.37	0.36	0.40	0.39
11	0.37	0.36	0.40	0.39
12	0.37	0.36	0.40	0.39
<i>Average</i>	<i>0.37</i>	<i>0.36</i>	<i>0.40</i>	<i>0.39</i>

Repeatability 2 LRT –Average Response Time (ms) Distribution Graph

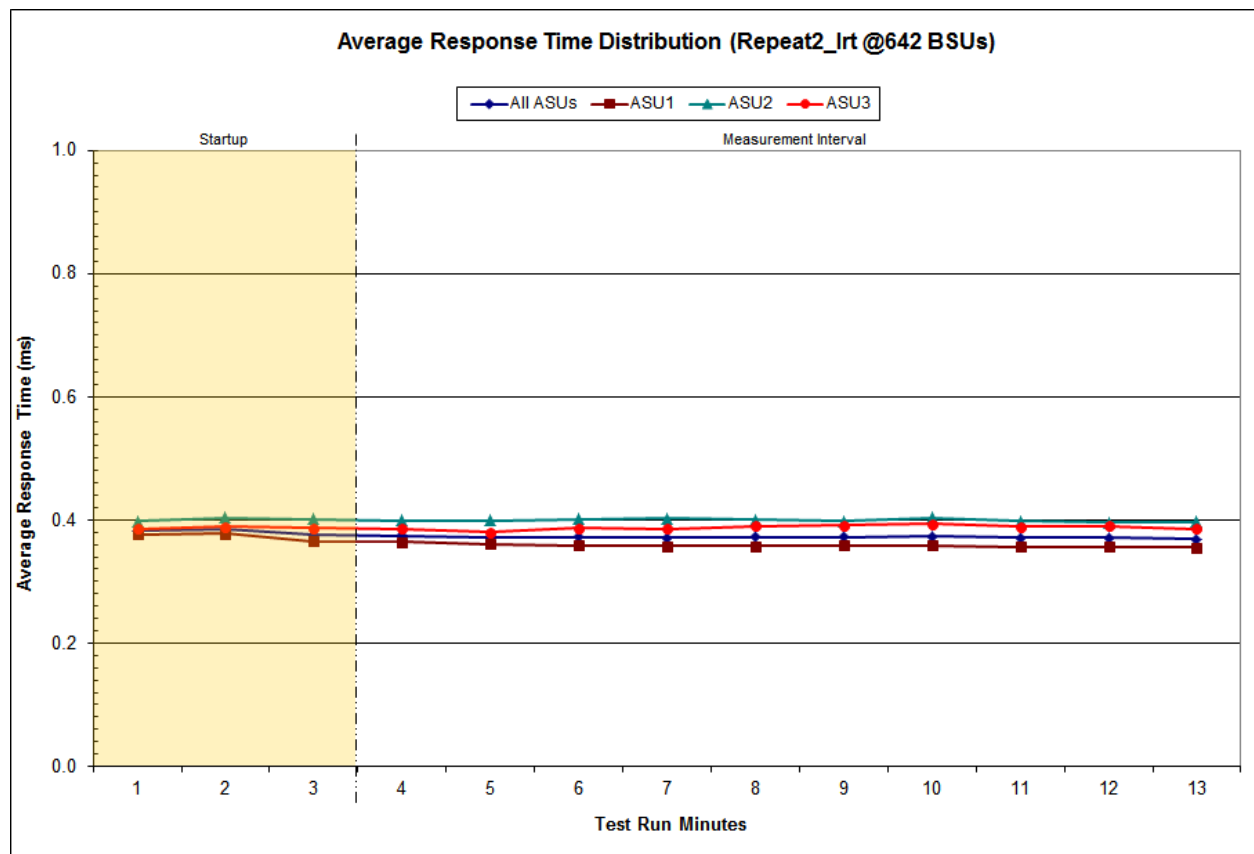

Repeatability 2 IOPS – I/O Request Throughput Distribution Data

6,420 BSUs	Start	Stop	Interval	Duration
<i>Start-Up/Ramp-Up</i>	10:50:00	10:53:01	0-2	0:03:01
<i>Measurement Interval</i>	10:53:01	11:03:01	3-12	0:10:00
60 second intervals	All ASUs	ASU1	ASU2	ASU3
0	320,986.67	191,305.98	39,502.22	90,178.47
1	320,923.83	191,313.32	39,467.17	90,143.35
2	321,189.77	191,459.62	39,505.72	90,224.43
3	320,936.13	191,296.00	39,474.32	90,165.82
4	320,935.58	191,269.35	39,445.72	90,220.52
5	321,017.58	191,302.13	39,468.80	90,246.65
6	321,024.12	191,380.63	39,472.92	90,170.57
7	320,973.20	191,315.65	39,488.00	90,169.55
8	321,023.33	191,346.30	39,490.47	90,186.57
9	320,960.20	191,266.32	39,494.08	90,199.80
10	321,037.50	191,361.63	39,472.68	90,203.18
11	321,035.50	191,275.53	39,494.15	90,265.82
12	320,980.95	191,296.82	39,468.02	90,216.12
Average	320,992.41	191,311.04	39,476.92	90,204.46

Repeatability 2 IOPS – I/O Request Throughput Distribution Graph

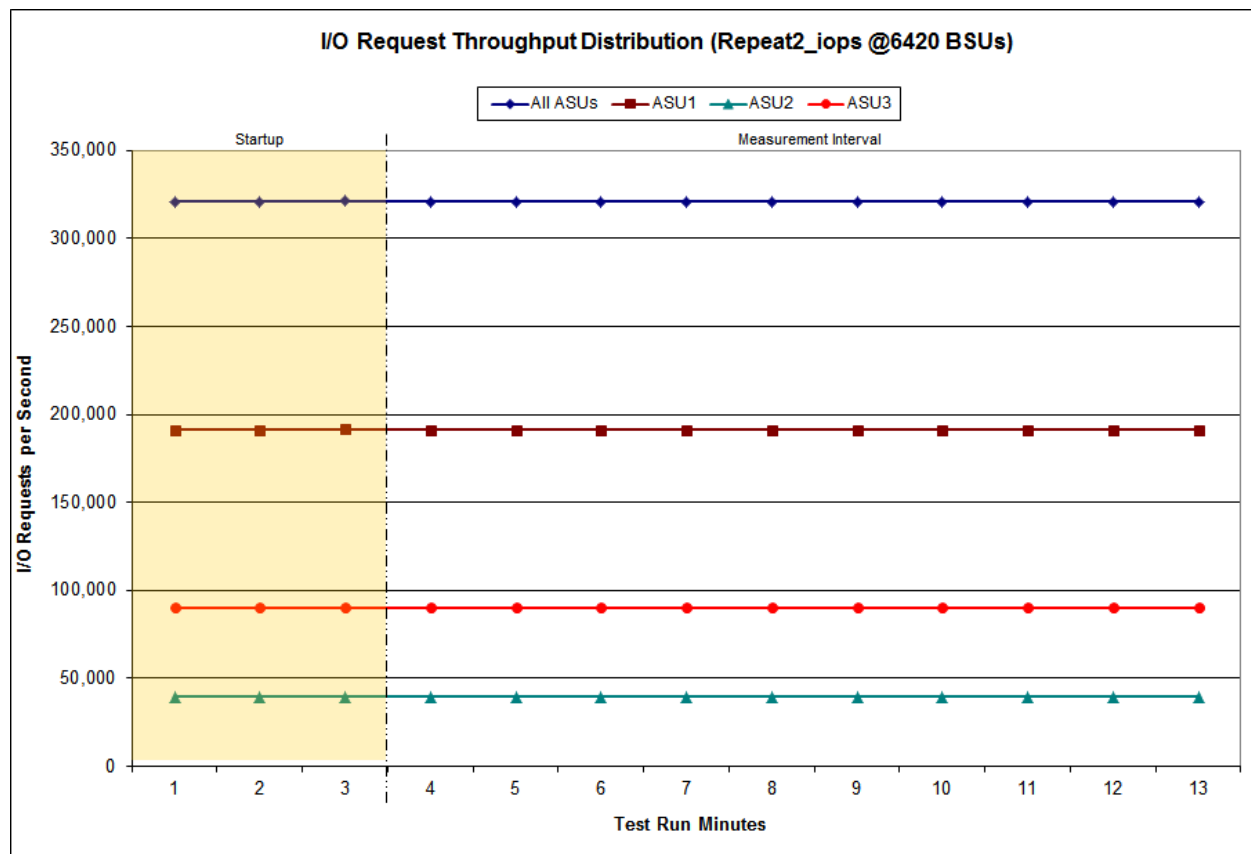

Repeatability 2 IOPS –Average Response Time (ms) Distribution Data

6,420 BSUs	Start	Stop	Interval	Duration
<i>Start-Up/Ramp-Up</i>	10:50:00	10:53:01	0-2	0:03:01
<i>Measurement Interval</i>	10:53:01	11:03:01	3-12	0:10:00
60 second intervals	All ASUs	ASU1	ASU2	ASU3
0	0.70	0.72	0.76	0.61
1	0.70	0.73	0.76	0.61
2	0.68	0.71	0.77	0.60
3	0.69	0.71	0.77	0.60
4	0.69	0.71	0.76	0.60
5	0.70	0.72	0.78	0.62
6	0.70	0.72	0.78	0.62
7	0.69	0.71	0.76	0.60
8	0.69	0.72	0.77	0.60
9	0.70	0.72	0.77	0.62
10	0.70	0.72	0.77	0.61
11	0.69	0.72	0.77	0.61
12	0.70	0.72	0.77	0.61
Average	0.69	0.72	0.77	0.61

Repeatability 2 IOPS –Average Response Time (ms) Distribution Graph

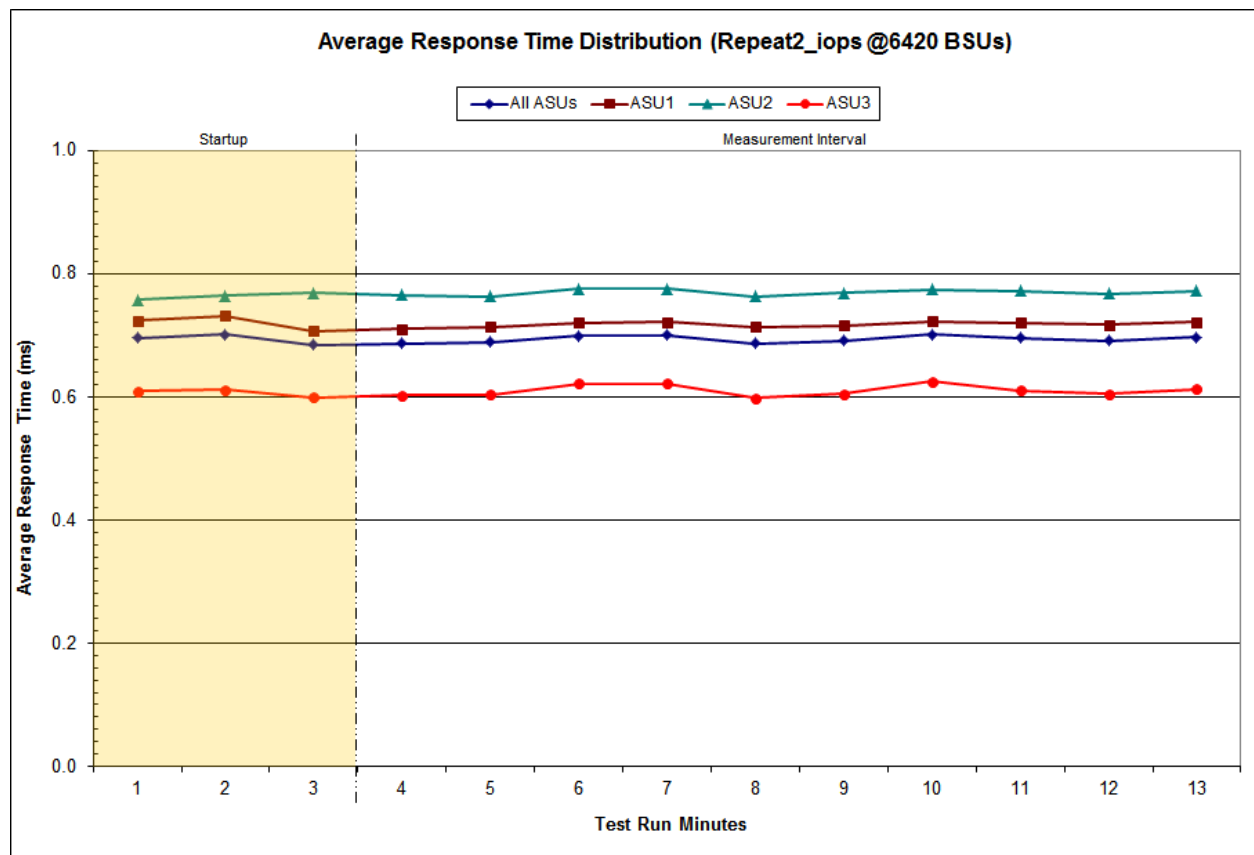

Repeatability 1 (LRT)
Measured Intensity Multiplier and Coefficient of Variation

Clause 3.4.3

IM – Intensity Multiplier: The ratio of I/Os for each I/O stream relative to the total I/Os for all I/O streams (ASU1-1 – ASU3-1) as required by the benchmark specification.

Clauses 5.1.10 and 5.3.15.2

MIM – Measured Intensity Multiplier: The Measured Intensity Multiplier represents the ratio of measured I/Os for each I/O stream relative to the total I/Os measured for all I/O streams (ASU1-1 – ASU3-1). This value may differ from the corresponding Expected Intensity Multiplier by no more than 5%.

Clause 5.3.15.3

COV – Coefficient of Variation: This measure of variation for the Measured Intensity Multiplier cannot exceed 0.2.

	ASU1-1	ASU1-2	ASU1-3	ASU1-4	ASU2-1	ASU2-2	ASU2-3	ASU3-1
IM	0.0350	0.2810	0.0700	0.2100	0.0180	0.0700	0.0350	0.2810
MIM	0.0349	0.2811	0.0702	0.2100	0.0180	0.0699	0.0350	0.2809
COV	0.003	0.001	0.004	0.001	0.005	0.003	0.003	0.001

Repeatability 1 (IOPS)
Measured Intensity Multiplier and Coefficient of Variation

	ASU1-1	ASU1-2	ASU1-3	ASU1-4	ASU2-1	ASU2-2	ASU2-3	ASU3-1
IM	0.0350	0.2810	0.0700	0.2100	0.0180	0.0700	0.0350	0.2810
MIM	0.0350	0.2810	0.0700	0.2100	0.0180	0.0700	0.0350	0.2810
COV	0.001	0.001	0.001	0.000	0.002	0.001	0.001	0.000

Repeatability 2 (LRT)
Measured Intensity Multiplier and Coefficient of Variation

	ASU1-1	ASU1-2	ASU1-3	ASU1-4	ASU2-1	ASU2-2	ASU2-3	ASU3-1
IM	0.0350	0.2810	0.0700	0.2100	0.0180	0.0700	0.0350	0.2810
MIM	0.0350	0.2810	0.0700	0.2100	0.0180	0.0700	0.0350	0.2811
COV	0.004	0.002	0.002	0.001	0.006	0.002	0.003	0.001

Repeatability 2 (IOPS)
Measured Intensity Multiplier and Coefficient of Variation

	ASU1-1	ASU1-2	ASU1-3	ASU1-4	ASU2-1	ASU2-2	ASU2-3	ASU3-1
<i>IM</i>	<i>0.0350</i>	<i>0.2810</i>	<i>0.0700</i>	<i>0.2100</i>	<i>0.0180</i>	<i>0.0700</i>	<i>0.0350</i>	<i>0.2810</i>
MIM	0.0350	0.2810	0.0700	0.2100	0.0180	0.0700	0.0350	0.2810
COV	0.001	0.000	0.001	0.001	0.001	0.001	0.001	0.000

Data Persistence Test

Clause 6

The Data Persistence Test demonstrates the Tested Storage Configuration (TSC):

- *Is capable of maintain data integrity across a power cycle.*
- *Ensures the transfer of data between Logical Volumes and host systems occurs without corruption or loss.*

The SPC-1 Workload Generator will write 16 block I/O requests at random over the total Addressable Storage Capacity of the TSC for ten (10) minutes at a minimum of 25% of the load used to generate the SPC-1 IOPS™ primary metric. The bit pattern selected to be written to each block as well as the address of the block will be retained in a log file.

The Tested Storage Configuration (TSC) will be shutdown and restarted using a power off/power on cycle at the end of the above sequence of write operations. In addition, any caches employing battery backup must be flushed/emptied.

The SPC-1 Workload Generator will then use the above log file to verify each block written contains the correct bit pattern.

Clause 9.4.3.8

The following content shall appear in this section of the FDR:

1. *A listing or screen image of all input parameters supplied to the Workload Generator.*
2. *For the successful Data Persistence Test Run, a table illustrating key results. The content, appearance, and format of this table are specified in Table 9-12. Information displayed in this table shall be obtained from the Test Run Results File referenced below in #3.*
3. *For the successful Data Persistence Test Run, the human readable Test Run Results file produced by the Workload Generator (may be contained in an appendix).*

SPC-1 Workload Generator Input Parameters

The SPC-1 Workload Generator input parameters for the Sustainability, IOPS, Response Time Ramp, Repeatability, and Persistence Test Runs are documented in [Appendix E: SPC-1 Workload Generator Input Parameters](#) on Page [80](#).

Data Persistence Test Results File

A link to each test result file generated from each Data Persistence Test is listed below.

[Persistence 1 Test Results File](#)

[Persistence 2 Test Results File](#)

Data Persistence Test Results

Data Persistence Test Results	
Data Persistence Test Run Number: 1	
Total Number of Logical Blocks Written	358,732,608
Total Number of Logical Blocks Verified	186,085,312
Total Number of Logical Blocks that Failed Verification	0
Time Duration for Writing Test Logical Blocks	10 minutes
Size in bytes of each Logical Block	512
Number of Failed I/O Requests in the process of the Test	0

In some cases the same address was the target of multiple writes, which resulted in more Logical Blocks Written than Logical Blocks Verified. In the case of multiple writes to the same address, the pattern written and verified must be associated with the last write to that address.

PRICED STORAGE CONFIGURATION AVAILABILITY DATE

Clause 9.4.3.9

The committed delivery data for general availability (Availability Date) of all products that comprise the Priced Storage Configuration must be reported. When the Priced Storage Configuration includes products or components with different availability dates, the reported Availability Date for the Priced Storage Configuration must be the date at which all components are committed to be available.

The Huawei OceanStor™ 5500 V3 as documented in this Full Disclosure Report is currently available for customer purchase and shipment.

PRICING INFORMATION

Clause 9.4.3.3.6

The Executive Summary shall contain a pricing spreadsheet as documented in Clause 8.3.1.

Pricing information may be found in the Priced Storage Configuration Pricing section on page [17](#).

TESTED STORAGE CONFIGURATION (TSC) AND PRICED STORAGE CONFIGURATION DIFFERENCES

Clause 9.4.3.3.8

The Executive Summary shall contain a list of all differences between the Tested Storage Configuration (TSC) and the Priced Storage Configuration.

A list of all differences between the Tested Storage Configuration (TSC) and Priced Storage Configuration may be found in the Executive Summary portion of this document on page [17](#).

ANOMALIES OR IRREGULARITIES

Clause 9.4.3.10

The FDR shall include a clear and complete description of any anomalies or irregularities encountered in the course of executing the SPC-1 benchmark that may in any way call into question the accuracy, verifiability, or authenticity of information published in this FDR.

There were no anomalies or irregularities encountered during the SPC-1 Remote Audit of the Huawei OceanStor™ 5500 V3.

APPENDIX A: SPC-1 GLOSSARY

“Decimal” (*powers of ten*) Measurement Units

In the storage industry, the terms “kilo”, “mega”, “giga”, “tera”, “peta”, and “exa” are commonly used prefixes for computing performance and capacity. For the purposes of the SPC workload definitions, all of the following terms are defined in “powers of ten” measurement units.

A kilobyte (KB) is equal to 1,000 (10^3) bytes.

A megabyte (MB) is equal to 1,000,000 (10^6) bytes.

A gigabyte (GB) is equal to 1,000,000,000 (10^9) bytes.

A terabyte (TB) is equal to 1,000,000,000,000 (10^{12}) bytes.

A petabyte (PB) is equal to 1,000,000,000,000,000 (10^{15}) bytes

An exabyte (EB) is equal to 1,000,000,000,000,000,000 (10^{18}) bytes

“Binary” (*powers of two*) Measurement Units

The sizes reported by many operating system components use “powers of two” measurement units rather than “power of ten” units. The following standardized definitions and terms are also valid and may be used in this document.

A kibibyte (KiB) is equal to 1,024 (2^{10}) bytes.

A mebibyte (MiB) is equal to 1,048,576 (2^{20}) bytes.

A gibibyte (GiB) is equal to 1,073,741,824 (2^{30}) bytes.

A tebibyte (TiB) is equal to 1,099,511,627,776 (2^{40}) bytes.

A pebibyte (PiB) is equal to 1,125,899,906,842,624 (2^{50}) bytes.

An exbibyte (EiB) is equal to 1,152,921,504,606,846,967 (2^{60}) bytes.

SPC-1 Data Repository Definitions

Total ASU Capacity: The total storage capacity read and written in the course of executing the SPC-1 benchmark.

Application Storage Unit (ASU): The logical interface between the storage and SPC-1 Workload Generator. The three ASUs (Data, User, and Log) are typically implemented on one or more Logical Volume.

Logical Volume: The division of Addressable Storage Capacity into individually addressable logical units of storage used in the SPC-1 benchmark. Each Logical Volume is implemented as a single, contiguous address space.

Addressable Storage Capacity: The total storage (sum of Logical Volumes) that can be read and written by application programs such as the SPC-1 Workload Generator.

Configured Storage Capacity: This capacity includes the Addressable Storage Capacity and any other storage (parity disks, hot spares, etc.) necessary to implement the Addressable Storage Capacity.

Physical Storage Capacity: The formatted capacity of all storage devices physically present in the Tested Storage Configuration (TSC).

Data Protection Overhead: The storage capacity required to implement the selected level of data protection.

Required Storage: The amount of Configured Storage Capacity required to implement the Addressable Storage Configuration, excluding the storage required for the three ASUs.

Global Storage Overhead: The amount of Physical Storage Capacity that is required for storage subsystem use and unavailable for use by application programs.

Total Unused Storage: The amount of storage capacity available for use by application programs but not included in the Total ASU Capacity.

SPC-1 Data Protection Levels

Protected 1: The single point of failure of any *storage device* in the configuration will not result in permanent loss of access to or integrity of the SPC-1 Data Repository.

Protected 2: The single point of failure of any *component* in the configuration will not result in permanent loss of access to or integrity of the SPC-1 Data Repository.

SPC-1 Test Execution Definitions

Average Response Time: The sum of the Response Times for all Measured I/O Requests divided by the total number of Measured I/O Requests.

Completed I/O Request: An I/O Request with a Start Time and a Completion Time (see “I/O Completion Types” below).

Completion Time: The time recorded by the Workload Generator when an I/O Request is satisfied by the TSC as signaled by System Software.

Data Rate: The data transferred in all Measured I/O Requests in an SPC-1 Test Run divided by the length of the Test Run in seconds.

Expected I/O Count: For any given I/O Stream and Test Phase, the product of 50 times the BSU level, the duration of the Test Phase in seconds, and the Intensity Multiplier for that I/O Stream.

Failed I/O Request: Any I/O Request issued by the Workload Generator that could not be completed or was signaled as failed by System Software. A Failed I/O Request has no Completion Time (see “I/O Completion Types” below).

I/O Request Throughput: The total number of Measured I/O requests in an SPC-1 Test Run divided by the duration of the Measurement Interval in seconds.

In-Flight I/O Request: An I/O Request issued by the I/O Command Generator to the TSC that has a recorded Start Time, but does not complete within the Measurement Interval (see “I/O Completion Types” below).

Measured I/O Request: A Completed I/O Request with a Completion Time occurring within the Measurement Interval (see “I/O Completion Types” below).

Measured Intensity Multiplier: The percentage of all Measured I/O Requests that were issued by a given I/O Stream.

Measurement Interval: The finite and contiguous time period, after the TSC has reached Steady State, when data is collected by a Test Sponsor to generate an SPC-1 test result or support an SPC-1 test result.

Ramp-Up: The time required for the Benchmark Configuration (BC) to produce Steady State throughput after the Workload Generator begins submitting I/O Requests to the TSC for execution.

Ramp-Down: The time required for the BC to complete all I/O Requests issued by the Workload Generator. The Ramp-Down period begins when the Workload Generator ceases to issue new I/O Requests to the TSC.

Response Time: The Response Time of a Measured I/O Request is its Completion Time minus its Start Time.

Start Time: The time recorded by the Workload Generator when an I/O Request is submitted, by the Workload Generator, to the System Software for execution on the Tested Storage Configuration (TSC).

Start-Up: The period that begins after the Workload Generator starts to submit I/O requests to the TSC and ends at the beginning of the Measurement Interval.

Shut-Down: The period between the end of the Measurement Interval and the time when all I/O Requests issued by the Workload Generator have completed or failed.

Steady State: The consistent and sustainable throughput of the TSC. During this period the load presented to the TSC by the Workload Generator is constant.

Test: A collection of Test Phases and or Test Runs sharing a common objective.

Test Run: The execution of SPC-1 for the purpose of producing or supporting an SPC-1 test result. SPC-1 Test Runs may have a finite and measured Ramp-Up period, Start-Up period, Shut-Down period, and Ramp-Down period as illustrated in the “SPC-1 Test Run Components” below. All SPC-1 Test Runs shall have a Steady State period and a Measurement Interval.

Test Phase: A collection of one or more SPC-1 Test Runs sharing a common objective and intended to be run in a specific sequence.

I/O Completion Types

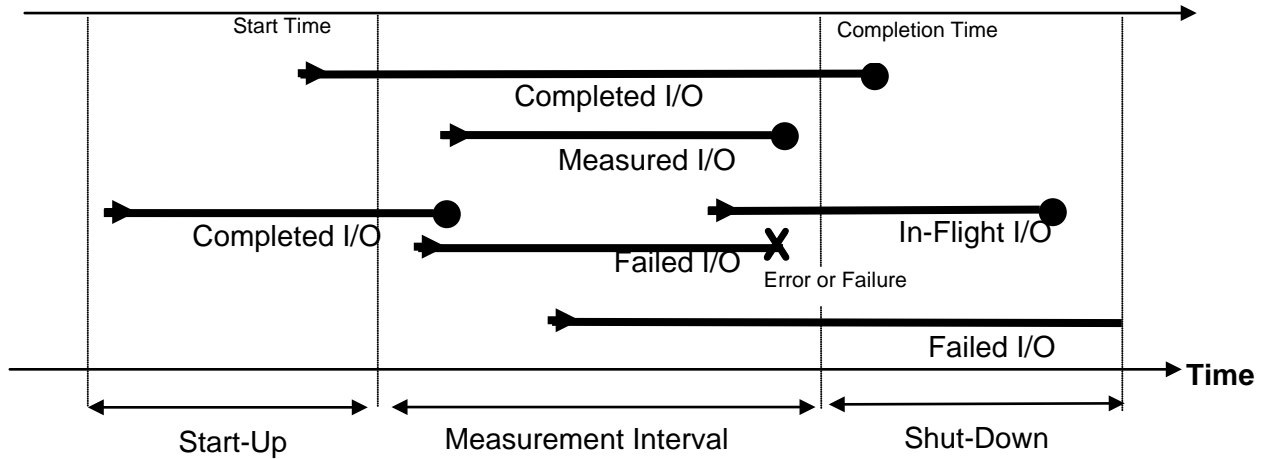

SPC-1 Test Run Components

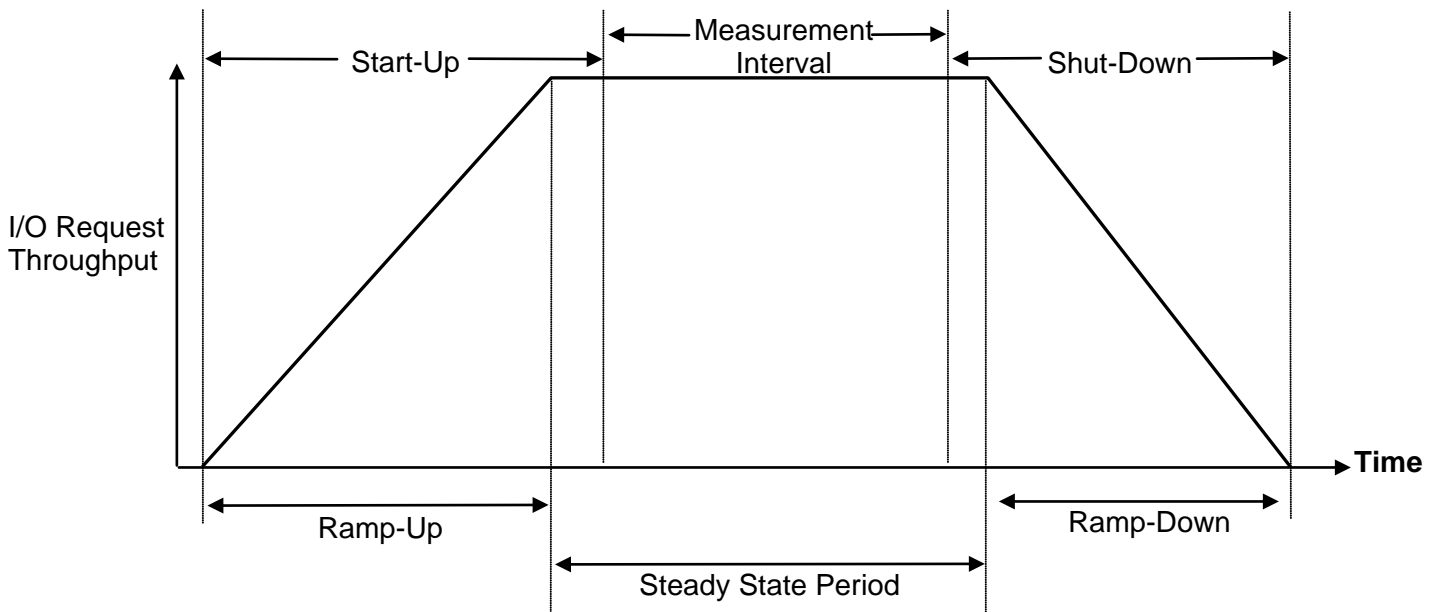

APPENDIX B: CUSTOMER TUNABLE PARAMETERS AND OPTIONS

Red Hat Enterprise Linux 7.0 (64-bit)

Change the I/O scheduler from **cfq** to **noop** on each Host System, which will result in all incoming I/O requests inserted into a simple, unordered FIFO queue. This change was done by the execution of the [scheduler.sh](#) script as documented in [Appendix C: Tested Storage Configuration \(TSC\) Creation](#).

APPENDIX C: TESTED STORAGE CONFIGURATION (TSC) CREATION

The scripts referenced in Steps 2 and 3 appear in the section, [Referenced Scripts](#).

Step 1: Create Mapping View, LUN Group, Host Group and Host

Execute the following commands using the OceanStor 5600 V3 CLI from the master Host System to complete the following:

- Create one *mapping_view* (*map1*)
- Create one *lun_group* (*lg1*)
- Create one *host_group* (*hg1*)
- Create one *host* (*host1*)
- Add *host1* to *hg1*
- Add *hg1* and *lg1* to *map1*
- Add the FC ports' WWN to *host1*

```
create mapping_view name=map1 mapping_view_id=1
create lun_group name=lg1 lun_group_id=1
create host_group name=hg1 host_group_id=1
create host name=host1 operating_system=Linux host_id=1
```

```
add host_group host host_group_id=1 host_id_list=1
add mapping_view host_group mapping_view_id=1 host_group_id=1
add mapping_view lun_group mapping_view_id=1 lun_group_id=1
```

```
add host initiator host_id=1 initiator_type=FC wwn=21000024ff29aff6
add host initiator host_id=1 initiator_type=FC wwn=21000024ff29aff7
add host initiator host_id=1 initiator_type=FC wwn=21000024ff2c953e
add host initiator host_id=1 initiator_type=FC wwn=21000024ff371eed
add host initiator host_id=1 initiator_type=FC wwn=21000024ff37555c
add host initiator host_id=1 initiator_type=FC wwn=21000024ff3cb159
add host initiator host_id=1 initiator_type=FC wwn=21000024ff3cc450
add host initiator host_id=1 initiator_type=FC wwn=21000024ff3cc451
add host initiator host_id=1 initiator_type=FC wwn=21000024ff3cc528
add host initiator host_id=1 initiator_type=FC wwn=21000024ff49992d
add host initiator host_id=1 initiator_type=FC wwn=21000024ff4b8195
add host initiator host_id=1 initiator_type=FC wwn=21000024ff4b829d
add host initiator host_id=1 initiator_type=FC wwn=21000024ff4b900d
add host initiator host_id=1 initiator_type=FC wwn=21000024ff536aeb
add host initiator host_id=1 initiator_type=FC wwn=2101001b322b463e
add host initiator host_id=1 initiator_type=FC wwn=50014380186b22fc
```

Step 2: Create Disk Domains, Storage Pools, LUNs

Execute the [mklun.sh](#) script on the Host System, which has **expect** installed to complete the following:

- Create 2 disk domains
- Create 2 storage pools
(one storage pool per disk domain using all available capacity)
- Create 12 LUNs
(two LUNs per storage pool using all available capacity)
- Add the 12 LUNs to **lun_group, lg1**

*Note: **Expect** is a Unix automation and testing tool, written by Don Libes as an extension to the Tcl scripting language, for interactive applications such as telnet, ftp, passwd, fsck, rlogin, tip, ssh, and others. It uses Unix pseudo terminals to wrap up subprocesses transparently, allowing the automation of arbitrary applications that are accessed over a terminal. Expect is an open source tool can be downloaded at the following location: <http://www.nist.gov/el/msid/expect.cfm>*

Step 3: Create Volumes on the Master Host System

Execute the [mkvolume.sh](#) script on the Master Host System to create 38 logical volumes as follows:

1. Create Physical Volume

Create 12 physical volumes using the **pvccreate** command.

2. Create Volumes Groups

Create one volume group (**vg1**) using the **vgcreate** command and the following 12 physical volumes:

/dev/sdb, /dev/sdc, /dev/sdd, /dev/sde, /dev/sdf, /dev/sdg, /dev/sdh, /dev/sdi, /dev/sdj, /dev/sdk, /dev/sdl, /dev/sdm

3. Create Logical Volumes

- Create 18 logical volumes, each with a capacity of 157.5 GiB, on **vg1** for ASU-1.
- Create 18 logical volumes, each with a capacity of 157.5 GiB, on **vg1** for ASU-2.
- Create 2 logical volumes, each with a capacity of 315 GiB, on **vg1** for ASU-3.

Step 4: Change the Scheduler on each Host System

Execute the [scheduler.sh](#) script on the Host System to change the scheduler of each block device from **cfq** to **noop**.

Referenced Scripts

mklun.sh

```
#!/bin/bash

stor=100.148.52.153
stor_user=admin
stor_pswd=Admin@storage1

export LANG=C

echo "creating LUN ..."

expect <<__END_CREATE_LUN
    spawn ssh $stor_user@$stor
    set timeout 60
    expect {
        -re "assword" { send "$stor_pswd\r" }
        -re "yes/no" { send "yes\r"; exp_continue }
    }
    expect ">"

# -----create disk_domain-----
send "create disk_domain name=ASU000 disk_list=CTE0.0-8,DAE010.0-15
disk_domain_id=0\r"
expect ">"
send "create disk_domain name=ASU100 disk_list=CTE1.0-8,DAE110.0-15
disk_domain_id=1\r"
expect ">"

# -----create storage_pool -----
send "create storage_pool name=ASU000 disk_type=SSD capacity=3928GB pool_id=0
disk_domain_id=0 raid_level=RAID10 stripe_depth=32KB\r"
expect ">"
send "create storage_pool name=ASU100 disk_type=SSD capacity=3928GB pool_id=1
disk_domain_id=1 raid_level=RAID10 stripe_depth=32KB\r"
expect ">"

# -----create lun -----
send "create lun name=ASU000 pool_id=0 capacity=654GB owner_controller=0A
lun_id=0\r"
expect ">"
send "create lun name=ASU001 pool_id=0 capacity=654GB owner_controller=0B
lun_id=1\r"
expect ">"
send "create lun name=ASU002 pool_id=0 capacity=654GB owner_controller=0A
lun_id=2\r"
expect ">"
send "create lun name=ASU003 pool_id=0 capacity=654GB owner_controller=0B
lun_id=3\r"
expect ">"
send "create lun name=ASU004 pool_id=0 capacity=654GB owner_controller=0A
lun_id=4\r"
expect ">"
send "create lun name=ASU005 pool_id=0 capacity=654GB owner_controller=0B
lun_id=5\r"
expect ">"
```

```
send "create lun name=ASU100 pool_id=1 capacity=654GB owner_controller=1A
lun_id=6\r"
expect ">"
send "create lun name=ASU101 pool_id=1 capacity=654GB owner_controller=1B
lun_id=7\r"
expect ">"
send "create lun name=ASU102 pool_id=1 capacity=654GB owner_controller=1A
lun_id=8\r"
expect ">"
send "create lun name=ASU103 pool_id=1 capacity=654GB owner_controller=1B
lun_id=9\r"
expect ">"
send "create lun name=ASU104 pool_id=1 capacity=654GB owner_controller=1A
lun_id=10\r"
expect ">"
send "create lun name=ASU105 pool_id=1 capacity=654GB owner_controller=1B
lun_id=11\r"
expect ">"

# ----- add all luns to lun_group-----
send "add lun_group lun lun_group_id=1
lun_id_list=0,1,6,7,2,3,8,9,4,5,10,11"
expect ">"

send "exit\r"
expect "(y/n):"
send "y\r"
expect EOF
__END_CREATE_LUN
```

mkvolume.sh

```
pvcreate /dev/sdb
pvcreate /dev/sdc
pvcreate /dev/sdd
pvcreate /dev/sde
pvcreate /dev/sdf
pvcreate /dev/sdg
pvcreate /dev/sdh
pvcreate /dev/sdi
pvcreate /dev/sdj
pvcreate /dev/sdk
pvcreate /dev/sdl
pvcreate /dev/sdm

vgcreate vg1 /dev/sdb /dev/sdc /dev/sdd /dev/sde /dev/sdf /dev/sdg /dev/sdh /dev/sdi
/dev/sdj /dev/sdk /dev/sdl /dev/sdm

lvcreate -n asu101 -i 12 -I 512 -C y -L 157.5g vg1
lvcreate -n asu102 -i 12 -I 512 -C y -L 157.5g vg1
lvcreate -n asu103 -i 12 -I 512 -C y -L 157.5g vg1
lvcreate -n asu104 -i 12 -I 512 -C y -L 157.5g vg1
lvcreate -n asu105 -i 12 -I 512 -C y -L 157.5g vg1
lvcreate -n asu106 -i 12 -I 512 -C y -L 157.5g vg1
lvcreate -n asu107 -i 12 -I 512 -C y -L 157.5g vg1
lvcreate -n asu108 -i 12 -I 512 -C y -L 157.5g vg1
lvcreate -n asu109 -i 12 -I 512 -C y -L 157.5g vg1
lvcreate -n asu110 -i 12 -I 512 -C y -L 157.5g vg1
```

```
lvcreate -n asu111 -i 12 -I 512 -C y -L 157.5g vg1
lvcreate -n asu112 -i 12 -I 512 -C y -L 157.5g vg1
lvcreate -n asu113 -i 12 -I 512 -C y -L 157.5g vg1
lvcreate -n asu114 -i 12 -I 512 -C y -L 157.5g vg1
lvcreate -n asu115 -i 12 -I 512 -C y -L 157.5g vg1
lvcreate -n asu116 -i 12 -I 512 -C y -L 157.5g vg1
lvcreate -n asu117 -i 12 -I 512 -C y -L 157.5g vg1
lvcreate -n asu118 -i 12 -I 512 -C y -L 157.5g vg1

lvcreate -n asu201 -i 12 -I 512 -C y -L 157.5g vg1
lvcreate -n asu202 -i 12 -I 512 -C y -L 157.5g vg1
lvcreate -n asu203 -i 12 -I 512 -C y -L 157.5g vg1
lvcreate -n asu204 -i 12 -I 512 -C y -L 157.5g vg1
lvcreate -n asu205 -i 12 -I 512 -C y -L 157.5g vg1
lvcreate -n asu206 -i 12 -I 512 -C y -L 157.5g vg1
lvcreate -n asu207 -i 12 -I 512 -C y -L 157.5g vg1
lvcreate -n asu208 -i 12 -I 512 -C y -L 157.5g vg1
lvcreate -n asu209 -i 12 -I 512 -C y -L 157.5g vg1
lvcreate -n asu210 -i 12 -I 512 -C y -L 157.5g vg1
lvcreate -n asu211 -i 12 -I 512 -C y -L 157.5g vg1
lvcreate -n asu212 -i 12 -I 512 -C y -L 157.5g vg1
lvcreate -n asu213 -i 12 -I 512 -C y -L 157.5g vg1
lvcreate -n asu214 -i 12 -I 512 -C y -L 157.5g vg1
lvcreate -n asu215 -i 12 -I 512 -C y -L 157.5g vg1
lvcreate -n asu216 -i 12 -I 512 -C y -L 157.5g vg1
lvcreate -n asu217 -i 12 -I 512 -C y -L 157.5g vg1
lvcreate -n asu218 -i 12 -I 512 -C y -L 157.5g vg1

lvcreate -n asu301 -i 12 -I 512 -C y -L 315g vg1
lvcreate -n asu302 -i 12 -I 512 -C y -L 315g vg1
```

scheduler.sh

```
echo noop > /sys/block/sdb/queue/scheduler
echo noop > /sys/block/sdc/queue/scheduler
echo noop > /sys/block/sdd/queue/scheduler
echo noop > /sys/block/sde/queue/scheduler
echo noop > /sys/block/sdf/queue/scheduler
echo noop > /sys/block/sdg/queue/scheduler
echo noop > /sys/block/sdh/queue/scheduler
echo noop > /sys/block/sdi/queue/scheduler
echo noop > /sys/block/sdj/queue/scheduler
echo noop > /sys/block/sdk/queue/scheduler
echo noop > /sys/block/sdl/queue/scheduler
echo noop > /sys/block/sdm/queue/scheduler
```

APPENDIX D: SPC-1 WORKLOAD GENERATOR STORAGE COMMANDS AND PARAMETERS

ASU Pre-Fill

```
compratio=1
hd=default,vdbench=/root/vdbench,user=root,shell=ssh

hd=hd1,system=host1
hd=hd2,system=host2

sd=default,openflags=o_direct,threads=8

sd=sd1,host=hd1,lun=/dev/vg1/asu101,size=169114337280
sd=sd2,host=hd1,lun=/dev/vg1/asu102,size=169114337280
sd=sd3,host=hd1,lun=/dev/vg1/asu103,size=169114337280
sd=sd4,host=hd1,lun=/dev/vg1/asu104,size=169114337280
sd=sd5,host=hd2,lun=/dev/vg1/asu105,size=169114337280
sd=sd6,host=hd2,lun=/dev/vg1/asu106,size=169114337280
sd=sd7,host=hd2,lun=/dev/vg1/asu107,size=169114337280
sd=sd8,host=hd2,lun=/dev/vg1/asu108,size=169114337280
sd=sd9,host=hd1,lun=/dev/vg1/asu109,size=169114337280
sd=sd10,host=hd1,lun=/dev/vg1/asu110,size=169114337280
sd=sd11,host=hd1,lun=/dev/vg1/asu111,size=169114337280
sd=sd12,host=hd1,lun=/dev/vg1/asu112,size=169114337280
sd=sd13,host=hd2,lun=/dev/vg1/asu113,size=169114337280
sd=sd14,host=hd2,lun=/dev/vg1/asu114,size=169114337280
sd=sd15,host=hd2,lun=/dev/vg1/asu115,size=169114337280
sd=sd16,host=hd2,lun=/dev/vg1/asu116,size=169114337280
sd=sd17,host=hd1,lun=/dev/vg1/asu117,size=169114337280
sd=sd18,host=hd1,lun=/dev/vg1/asu118,size=169114337280

sd=sd19,host=hd1,lun=/dev/vg1/asu201,size=169114337280
sd=sd20,host=hd1,lun=/dev/vg1/asu202,size=169114337280
sd=sd21,host=hd2,lun=/dev/vg1/asu203,size=169114337280
sd=sd22,host=hd2,lun=/dev/vg1/asu204,size=169114337280
sd=sd23,host=hd2,lun=/dev/vg1/asu205,size=169114337280
sd=sd24,host=hd2,lun=/dev/vg1/asu206,size=169114337280
sd=sd25,host=hd1,lun=/dev/vg1/asu207,size=169114337280
sd=sd26,host=hd1,lun=/dev/vg1/asu208,size=169114337280
sd=sd27,host=hd1,lun=/dev/vg1/asu209,size=169114337280
sd=sd28,host=hd1,lun=/dev/vg1/asu210,size=169114337280
sd=sd29,host=hd2,lun=/dev/vg1/asu211,size=169114337280
sd=sd30,host=hd2,lun=/dev/vg1/asu212,size=169114337280
sd=sd31,host=hd2,lun=/dev/vg1/asu213,size=169114337280
sd=sd32,host=hd2,lun=/dev/vg1/asu214,size=169114337280
sd=sd33,host=hd1,lun=/dev/vg1/asu215,size=169114337280
sd=sd34,host=hd1,lun=/dev/vg1/asu216,size=169114337280
sd=sd35,host=hd1,lun=/dev/vg1/asu217,size=169114337280
sd=sd36,host=hd1,lun=/dev/vg1/asu218,size=169114337280

sd=sd37,host=hd2,lun=/dev/vg1/asu301,size=338228674560
sd=sd38,host=hd2,lun=/dev/vg1/asu302,size=338228674560

wd=wd1,sd=sd*,rdpct=0,seekpct=-1,xfersize=1024K
rd=PREPASU1,wd=wd1,iorate=max,elapsed=3600000,interval=10
```

Primary Metrics and Repeatability Tests

The content of SPC-1 Workload Generator command and parameter file used in this benchmark to execute the Primary Metrics (*Sustainability Test Phase, IOPS Test Phase, and Response Time Ramp Test Phase*) and Repeatability (*Repeatability Test Phase 1 and Repeatability Test Phase 2*) Tests is listed below.

```
host=master
slaves=(slave1,slave2,slave3,slave4,slave5,slave6,slave7,slave8,slave9,slave10,slave
11,slave12,slave13,slave14,slave15,slave16,slave17,slave18,slave19,slave20,slave21,s
lave22,slave23,slave24,slave25,slave26,slave27,slave28,slave29,slave30,slave31,slave
32,slave33,slave34,slave35,slave36,slave37,slave38,slave39,slave40,slave41,slave42,s
lave43,slave44,slave45,slave46,slave47,slave48,slave49,slave50,slave51,slave52,slave
53,slave54,slave55,slave56,slave57,slave58,slave59,slave60,slave61,slave62,slave63,s
lave64,slave65,slave66)

sd=asu1_1,lun=/dev/vg1/asu101,size=169114337280
sd=asu1_2,lun=/dev/vg1/asu102,size=169114337280
sd=asu1_3,lun=/dev/vg1/asu103,size=169114337280
sd=asu1_4,lun=/dev/vg1/asu104,size=169114337280
sd=asu1_5,lun=/dev/vg1/asu105,size=169114337280
sd=asu1_6,lun=/dev/vg1/asu106,size=169114337280
sd=asu1_7,lun=/dev/vg1/asu107,size=169114337280
sd=asu1_8,lun=/dev/vg1/asu108,size=169114337280
sd=asu1_9,lun=/dev/vg1/asu109,size=169114337280
sd=asu1_10,lun=/dev/vg1/asu110,size=169114337280
sd=asu1_11,lun=/dev/vg1/asu111,size=169114337280
sd=asu1_12,lun=/dev/vg1/asu112,size=169114337280
sd=asu1_13,lun=/dev/vg1/asu113,size=169114337280
sd=asu1_14,lun=/dev/vg1/asu114,size=169114337280
sd=asu1_15,lun=/dev/vg1/asu115,size=169114337280
sd=asu1_16,lun=/dev/vg1/asu116,size=169114337280
sd=asu1_17,lun=/dev/vg1/asu117,size=169114337280
sd=asu1_18,lun=/dev/vg1/asu118,size=169114337280

sd=asu2_1,lun=/dev/vg1/asu201,size=169114337280
sd=asu2_2,lun=/dev/vg1/asu202,size=169114337280
sd=asu2_3,lun=/dev/vg1/asu203,size=169114337280
sd=asu2_4,lun=/dev/vg1/asu204,size=169114337280
sd=asu2_5,lun=/dev/vg1/asu205,size=169114337280
sd=asu2_6,lun=/dev/vg1/asu206,size=169114337280
sd=asu2_7,lun=/dev/vg1/asu207,size=169114337280
sd=asu2_8,lun=/dev/vg1/asu208,size=169114337280
sd=asu2_9,lun=/dev/vg1/asu209,size=169114337280
sd=asu2_10,lun=/dev/vg1/asu210,size=169114337280
sd=asu2_11,lun=/dev/vg1/asu211,size=169114337280
sd=asu2_12,lun=/dev/vg1/asu212,size=169114337280
sd=asu2_13,lun=/dev/vg1/asu213,size=169114337280
sd=asu2_14,lun=/dev/vg1/asu214,size=169114337280
sd=asu2_15,lun=/dev/vg1/asu215,size=169114337280
sd=asu2_16,lun=/dev/vg1/asu216,size=169114337280
sd=asu2_17,lun=/dev/vg1/asu217,size=169114337280
sd=asu2_18,lun=/dev/vg1/asu218,size=169114337280

sd=asu3_1,lun=/dev/vg1/asu301,size=338228674560
sd=asu3_2,lun=/dev/vg1/asu302,size=338228674560
```

SPC-1 Persistence Test

The content of SPC-1 Workload Generator command and parameter file, used in this benchmark to execute the SPC-1 Persistence Test, is listed below.

```
sd=asu1_1,lun=/dev/vg1/asu101,size=169114337280
sd=asu1_2,lun=/dev/vg1/asu102,size=169114337280
sd=asu1_3,lun=/dev/vg1/asu103,size=169114337280
sd=asu1_4,lun=/dev/vg1/asu104,size=169114337280
sd=asu1_5,lun=/dev/vg1/asu105,size=169114337280
sd=asu1_6,lun=/dev/vg1/asu106,size=169114337280
sd=asu1_7,lun=/dev/vg1/asu107,size=169114337280
sd=asu1_8,lun=/dev/vg1/asu108,size=169114337280
sd=asu1_9,lun=/dev/vg1/asu109,size=169114337280
sd=asu1_10,lun=/dev/vg1/asu110,size=169114337280
sd=asu1_11,lun=/dev/vg1/asu111,size=169114337280
sd=asu1_12,lun=/dev/vg1/asu112,size=169114337280
sd=asu1_13,lun=/dev/vg1/asu113,size=169114337280
sd=asu1_14,lun=/dev/vg1/asu114,size=169114337280
sd=asu1_15,lun=/dev/vg1/asu115,size=169114337280
sd=asu1_16,lun=/dev/vg1/asu116,size=169114337280
sd=asu1_17,lun=/dev/vg1/asu117,size=169114337280
sd=asu1_18,lun=/dev/vg1/asu118,size=169114337280
```

```
sd=asu2_1,lun=/dev/vg1/asu201,size=169114337280
sd=asu2_2,lun=/dev/vg1/asu202,size=169114337280
sd=asu2_3,lun=/dev/vg1/asu203,size=169114337280
sd=asu2_4,lun=/dev/vg1/asu204,size=169114337280
sd=asu2_5,lun=/dev/vg1/asu205,size=169114337280
sd=asu2_6,lun=/dev/vg1/asu206,size=169114337280
sd=asu2_7,lun=/dev/vg1/asu207,size=169114337280
sd=asu2_8,lun=/dev/vg1/asu208,size=169114337280
sd=asu2_9,lun=/dev/vg1/asu209,size=169114337280
sd=asu2_10,lun=/dev/vg1/asu210,size=169114337280
sd=asu2_11,lun=/dev/vg1/asu211,size=169114337280
sd=asu2_12,lun=/dev/vg1/asu212,size=169114337280
sd=asu2_13,lun=/dev/vg1/asu213,size=169114337280
sd=asu2_14,lun=/dev/vg1/asu214,size=169114337280
sd=asu2_15,lun=/dev/vg1/asu215,size=169114337280
sd=asu2_16,lun=/dev/vg1/asu216,size=169114337280
sd=asu2_17,lun=/dev/vg1/asu217,size=169114337280
sd=asu2_18,lun=/dev/vg1/asu218,size=169114337280
```

```
sd=asu3_1,lun=/dev/vg1/asu301,size=338228674560
sd=asu3_2,lun=/dev/vg1/asu302,size=338228674560
```

APPENDIX E: SPC-1 WORKLOAD GENERATOR INPUT PARAMETERS

The following script, **run.sh**, was invoked to execute the following in an uninterrupted execution sequence:

- Generate the first set of detailed storage configuration information required for a remote audit.
- The required ASU pre-fill.
- Start the Slave JVMs on the two Host Systems
- The commands to execute the Primary Metrics Test (*Sustainability Test Phase, IOPS Test Phase, and Response Time Ramp Test Phase*), Repeatability Test (*Repeatability Test Phase 1 and Repeatability Test Phase 2*), and SPC-1 Persistence Test Run 1 (*write phase*).

After the above test sequence completed, the script paused until the required TSC power off/power on cycle completed then executed the following:

- Generate the second set of detailed storage configuration information required for a remote audit.
- The command to execute the SPC-2 Persistence Test Run 2 (*read phase*).

run.sh

```
#!/bin/sh

#JAVA="/usr/java/jre1.6.0_45/bin/java -d64 -Xms7168m -Xmx7168m -Xmn1792m -Xss192k -Xincgc"
JAVA="/usr/java/jre1.6.0_45/bin/java -Xmx7168m -Xincgc"
EXEDIR=/root/5500

expect shstorage.tcl > profile1_storage.log
date > profile1_volume.log
lvdisplay >> profile1_volume.log
date >> profile1_volume.log

echo "ASU prefill started....."
../vdbench/vdbench -f /root/5500/prefilling.cfg -o /root/5500/PreFill
echo "ASU prefill complete....."

N=1
for host in host1 host2
do
  ssh $host rm -rf $EXEDIR/output
  ssh $host rm -rf $EXEDIR/config
  ssh $host mkdir $EXEDIR/output
  ssh $host mkdir $EXEDIR/config
  for((i=1;i<=33;i++))
  do
    echo "start slave$N on $host"
    echo "master=host1" > $EXEDIR/config/slave$N.cfg
    echo "host=slave$N" >> $EXEDIR/config/slave$N.cfg

    echo "sd=asul_1,lun=/dev/vg1/asul01,size=169114337280" >> $EXEDIR/config/slave$N.cfg
    echo "sd=asul_2,lun=/dev/vg1/asul02,size=169114337280" >> $EXEDIR/config/slave$N.cfg
    echo "sd=asul_3,lun=/dev/vg1/asul03,size=169114337280" >> $EXEDIR/config/slave$N.cfg
    echo "sd=asul_4,lun=/dev/vg1/asul04,size=169114337280" >> $EXEDIR/config/slave$N.cfg
```



```
echo "sd=asul_5,lun=/dev/vg1/asul05,size=169114337280" >> $EXEDIR/config/slave$N.cfg
echo "sd=asul_6,lun=/dev/vg1/asul06,size=169114337280" >> $EXEDIR/config/slave$N.cfg
echo "sd=asul_7,lun=/dev/vg1/asul07,size=169114337280" >> $EXEDIR/config/slave$N.cfg
echo "sd=asul_8,lun=/dev/vg1/asul08,size=169114337280" >> $EXEDIR/config/slave$N.cfg
echo "sd=asul_9,lun=/dev/vg1/asul09,size=169114337280" >> $EXEDIR/config/slave$N.cfg
echo "sd=asul_10,lun=/dev/vg1/asul10,size=169114337280" >>
$EXEDIR/config/slave$N.cfg
echo "sd=asul_11,lun=/dev/vg1/asul11,size=169114337280" >>
$EXEDIR/config/slave$N.cfg
echo "sd=asul_12,lun=/dev/vg1/asul12,size=169114337280" >>
$EXEDIR/config/slave$N.cfg
echo "sd=asul_13,lun=/dev/vg1/asul13,size=169114337280" >>
$EXEDIR/config/slave$N.cfg
echo "sd=asul_14,lun=/dev/vg1/asul14,size=169114337280" >>
$EXEDIR/config/slave$N.cfg
echo "sd=asul_15,lun=/dev/vg1/asul15,size=169114337280" >>
$EXEDIR/config/slave$N.cfg
echo "sd=asul_16,lun=/dev/vg1/asul16,size=169114337280" >>
$EXEDIR/config/slave$N.cfg
echo "sd=asul_17,lun=/dev/vg1/asul17,size=169114337280" >>
$EXEDIR/config/slave$N.cfg
echo "sd=asul_18,lun=/dev/vg1/asul18,size=169114337280" >>
$EXEDIR/config/slave$N.cfg

echo "sd=asu2_1,lun=/dev/vg1/asu201,size=169114337280" >> $EXEDIR/config/slave$N.cfg
echo "sd=asu2_2,lun=/dev/vg1/asu202,size=169114337280" >> $EXEDIR/config/slave$N.cfg
echo "sd=asu2_3,lun=/dev/vg1/asu203,size=169114337280" >> $EXEDIR/config/slave$N.cfg
echo "sd=asu2_4,lun=/dev/vg1/asu204,size=169114337280" >> $EXEDIR/config/slave$N.cfg
echo "sd=asu2_5,lun=/dev/vg1/asu205,size=169114337280" >> $EXEDIR/config/slave$N.cfg
echo "sd=asu2_6,lun=/dev/vg1/asu206,size=169114337280" >> $EXEDIR/config/slave$N.cfg
echo "sd=asu2_7,lun=/dev/vg1/asu207,size=169114337280" >> $EXEDIR/config/slave$N.cfg
echo "sd=asu2_8,lun=/dev/vg1/asu208,size=169114337280" >> $EXEDIR/config/slave$N.cfg
echo "sd=asu2_9,lun=/dev/vg1/asu209,size=169114337280" >> $EXEDIR/config/slave$N.cfg
echo "sd=asu2_10,lun=/dev/vg1/asu210,size=169114337280" >>
$EXEDIR/config/slave$N.cfg
echo "sd=asu2_11,lun=/dev/vg1/asu211,size=169114337280" >>
$EXEDIR/config/slave$N.cfg
echo "sd=asu2_12,lun=/dev/vg1/asu212,size=169114337280" >>
$EXEDIR/config/slave$N.cfg
echo "sd=asu2_13,lun=/dev/vg1/asu213,size=169114337280" >>
$EXEDIR/config/slave$N.cfg
echo "sd=asu2_14,lun=/dev/vg1/asu214,size=169114337280" >>
$EXEDIR/config/slave$N.cfg
echo "sd=asu2_15,lun=/dev/vg1/asu215,size=169114337280" >>
$EXEDIR/config/slave$N.cfg
echo "sd=asu2_16,lun=/dev/vg1/asu216,size=169114337280" >>
$EXEDIR/config/slave$N.cfg
echo "sd=asu2_17,lun=/dev/vg1/asu217,size=169114337280" >>
$EXEDIR/config/slave$N.cfg
echo "sd=asu2_18,lun=/dev/vg1/asu218,size=169114337280" >>
$EXEDIR/config/slave$N.cfg

echo "sd=asu3_1,lun=/dev/vg1/asu301,size=338228674560" >> $EXEDIR/config/slave$N.cfg
echo "sd=asu3_2,lun=/dev/vg1/asu302,size=338228674560" >> $EXEDIR/config/slave$N.cfg

scp $EXEDIR/config/slave$N.cfg $host:$EXEDIR/config/slave$N.cfg
ssh $host "$JAVA -cp $EXEDIR/./spc1 spc1 -f $EXEDIR/config/slave$N.cfg -o
$EXEDIR/output/slave$N" > /dev/null &
N=$((N+1))
done
done
```

```
rm -rf spc1.cfg
cp metrics.cfg spc1.cfg

$JAVA -cp ../spc1 metrics -b 6420 -t 28800
$JAVA -cp ../spc1 repeat1 -b 6420
$JAVA -cp ../spc1 repeat2 -b 6420

for host in host2 host1
do
    ssh $host pkill -9 java
done

rm -rf spc1.cfg
cp persist.cfg spc1.cfg

$JAVA -cp ../spc1 persist1 -b 6420

echo "Power cycle TSC, then Enter to continue"
read

expect shstorage.tcl > profile2_storage.log
date > profile2_volume.log
lvdisplay >> profile2_volume.log
date >> profile2_volume.log

$JAVA -cp ../spc1 persist2
```

APPENDIX F: THIRD-PARTY QUOTATION

Priced Storage Configuration



Netfast Technology Solutions, Inc.
989, Avenues of America, Fl 12
New York, NY 10018, USA
Voice: (212) 792-5200 , Fax: (212) 213-1152

03/26/2016, Quote Valid:90 Days

No.	Model	Description	Qty.	Unit Price (USD)	Total Price (USD)
1	Phase				
1	Location				
1.1	OceanStor 5500 V3 Storage System				
1.1.1	Engine				
	55V3-128G-AC2-8	5500 V3(2U,Dual Ctrl,AC,128GB,SmartIO,8*8Gb FC,25*2.5",SPE33C0225)	2	12,217.20	24,434.40
1.1.2	Expand Interface Module				
	SMARTIO10ETH	4 port SmartIO I/O module (SFP+, 10Gb Eth/FCoE (VN2VF)/ Scale-out)	4	1,310.16	5,240.64
1.1.3	Disk Components				
	SSDM-400G2S-A1	SSD Midrange 400GB 2.5" SAS 6G Disk Unit	50	710.40	35,520.00
1.1.4	Installation Material				
	SN2F01FCPC	Patch Cord,DLC/PC,DLC/PC,Multi-mode,3m,A1a.2,2mm, OM3 bending insensitive	24	11.00	264.00
1.1.5	HBA				
	N8GHBA000	QLOGIC QLE2562 HBA Card,PCIE,8Gbps DualPort ,Fiber Channel Multimode LC Optic Interface,English Manual, No Drive CD	8	1,000.00	8,000.00
1.1.6	Storage Software				
	LIC-5500V3-BS	Basic Software License for Block(Include Device Management,SmartThin,SmartMulti-tenant,SmartMigration,SmartErase,SmartMotion,Ultrath, Cloud Service)	1	788.16	788.16
	LIC-5500V3-PATH	OceanStor HW UltraPath Software License	1	945.60	945.60
Total of Product					75,192.80
1.1.7	Maintenance Support Service				
	02350HYS-88134ULJ-3	5500 V3(2U,Dual Ctrl,AC,128GB,SmartIO,8*8Gb FC,25*2.5",SPE33C0225)-Warranty Upgrade To Hi-Care Onsite Premier 24x7x4H Engineer Onsite Service-3 Year(s)	2	3,059.99	6,119.98
	88032QRN-88134UHK-3	OceanStor HW UltraPath Software License-Hi-Care Application Software Upgrade Support Service-3 Year(s)	1	294.00	294.00
	88032QRA-88134UHK-3	Basic Software License for Block (Includes Device Management,SmartThin,SmartMulti-tenant, SmartMigration,SmartErase,SmartMotion,Cloud Service) Hi-Care Application Software Upgrade Support Service-3 Year(s)	1	294.00	294.00
Total of Service (3 years)					6,707.98
Total Price					81,900.78
Notes:Hi-Care Premier On-Site Service include: 7*24 Technical Assistance Center Access. Access to all new software updates and Online Support. 24*7*4 Hours Onsite Hardware Replacement.					