



**SPC BENCHMARK 1C™
FULL DISCLOSURE REPORT**

**LSI CORPORATION
LSI MEGARAID SAS 888ELP (24 DISKS)**

SPC-1C™ V1.1

**Submitted for Review: December 10, 2008
Submission Identifier: C00008**

First Edition - December 2008

THE INFORMATION CONTAINED IN THIS DOCUMENT IS DISTRIBUTED ON AN AS IS BASIS WITHOUT ANY WARRANTY EITHER EXPRESS OR IMPLIED. The use of this information or the implementation of any of these techniques is the customer's responsibility and depends on the customer's ability to evaluate and integrate them into the customer's operational environment. While each item has been reviewed by LSI Corporation for accuracy in a specific situation, there is no guarantee that the same or similar results will be obtained elsewhere. Customers attempting to adapt these techniques to their own environment do so at their own risk.

This publication was produced in the United States. LSI Corporation may not offer the products, services, or features discussed in this document in other countries, and the information is subject to change with notice. Consult your local LSI Corporation representative for information on products and services available in your area.

© Copyright LSI Corporation 2008. All rights reserved.

Permission is hereby granted to reproduce this document in whole or in part, provided the copyright notice as printed above is set forth in full text on the title page of each item reproduced.

Trademarks

SPC Benchmark-1C, SPC-1C, SPC-1C IOPS, and SPC-1C LRT are trademarks of the Storage Performance Council. LSI, the LSI logo, and MegaRAID are trademarks or registered trademarks of LSI Corporation in the United States and other countries. All other brands, trademarks, and product names are the property of their respective owners.

Table of Contents

Audit Certification	vii
Audit Certification (cont.)	viii
Letter of Good Faith	ix
Executive Summary	10
Test Sponsor and Contact Information	10
Revision Information and Key Dates	10
Tested Storage Product (TSP) Description	10
Summary of Results	11
Storage Capacities and Relationships	11
Response Time - Throughput Curve	12
Response Time - Throughput Data	12
Tested Storage Configuration Pricing (Priced Storage Configuration)	13
Differences between the Tested Storage Configuration (TSC) and Priced Storage Configuration	13
Benchmark Configuration/Tested Storage Configuration Diagram	14
Benchmark Configuration/Tested Storage Configuration Components	14
Configuration Information	15
Benchmark Configuration (BC)/Tested Storage Configuration (TSC) Diagram	15
Host System and Tested Storage Configuration	15
Customer Tunable Parameters and Options	15
Tested Storage Configuration (TSC) Description	15
SPC-1C Workload Generator Storage Configuration	16
SPC-1C Data Repository	17
Storage Capacities and Relationships	17
SPC-1C Storage Capacities	17
SPC-1C Storage Hierarchy Ratios	17
SPC-1C Storage Capacities and Relationships Illustration	18
Logical Volume Capacity and ASU Mapping	18
SPC-1C Benchmark Execution Results	19
SPC-1C Tests, Test Phases, and Test Runs	19
Primary Metrics Test - Sustainability Test Phase	20
SPC-1C Workload Generator Input Parameters.....	20
Sustainability Test Results File	20
Sustainability - Data Rate Distribution Data (<i>MB/second</i>).....	21
Sustainability - Data Rate Distribution Graph	22

Sustainability – I/O Request Throughput Distribution Data.....	23
Sustainability – I/O Request Throughput Distribution Graph	24
Sustainability – Average Response Time (ms) Distribution Data	25
Sustainability – Average Response Time (ms) Distribution Graph	26
Sustainability – Response Time Frequency Distribution Data	27
Sustainability – Response Time Frequency Distribution Graph	27
Sustainability – Measured Intensity Multiplier and Coefficient of Variation.....	28
Primary Metrics Test – IOPS Test Phase.....	29
SPC-1C Workload Generator Input Parameters.....	29
IOPS Test Results File.....	29
IOPS Test Run – I/O Request Throughput Distribution Data	30
IOPS Test Run – I/O Request Throughput Distribution Graph.....	30
IOPS Test Run – Average Response Time (ms) Distribution Data	31
IOPS Test Run – Average Response Time (ms) Distribution Graph	31
IOPS Test Run – Response Time Frequency Distribution Data	32
IOPS Test Run –Response Time Frequency Distribution Graph.....	32
IOPS Test Run – I/O Request Information.....	33
IOPS Test Run – Measured Intensity Multiplier and Coefficient of Variation.....	33
Primary Metrics Test – Response Time Ramp Test Phase	34
SPC-1C Workload Generator Input Parameters.....	34
Response Time Ramp Test Results File.....	34
Response Time Ramp Distribution (IOPS) Data.....	35
Response Time Ramp Distribution (IOPS) Graph	36
SPC-1C LRT™ Average Response Time (ms) Distribution Data	37
SPC-1C LRT™ Average Response Time (ms) Distribution Graph.....	37
SPC-1C LRT™ (10%) – Measured Intensity Multiplier and Coefficient of Variation....	38
Repeatability Test	39
SPC-1C Workload Generator Input Parameters.....	39
Repeatability Test Results File	40
Repeatability 1 LRT – I/O Request Throughput Distribution Data.....	41
Repeatability 1 LRT – I/O Request Throughput Distribution Graph	41
Repeatability 1 LRT –Average Response Time (ms) Distribution Data	42
Repeatability 1 LRT –Average Response Time (ms) Distribution Graph.....	42
Repeatability 1 IOPS – I/O Request Throughput Distribution Data	43
Repeatability 1 IOPS – I/O Request Throughput Distribution Graph.....	43
Repeatability 1 IOPS –Average Response Time (ms) Distribution Data.....	44
Repeatability 1 IOPS –Average Response Time (ms) Distribution Graph	44
Repeatability 2 LRT – I/O Request Throughput Distribution Data.....	45
Repeatability 2 LRT – I/O Request Throughput Distribution Graph	45

Repeatability 2 LRT –Average Response Time (ms) Distribution Data	46
Repeatability 2 LRT –Average Response Time (ms) Distribution Graph.....	46
Repeatability 2 IOPS – I/O Request Throughput Distribution Data	47
Repeatability 2 IOPS – I/O Request Throughput Distribution Graph.....	47
Repeatability 2 IOPS –Average Response Time (ms) Distribution Data.....	48
Repeatability 2 IOPS –Average Response Time (ms) Distribution Graph	48
Repeatability 1 (LRT) Measured Intensity Multiplier and Coefficient of Variation.....	49
Repeatability 1 (IOPS) Measured Intensity Multiplier and Coefficient of Variation	49
Repeatability 2 (LRT) Measured Intensity Multiplier and Coefficient of Variation	49
Repeatability 2 (IOPS) Measured Intensity Multiplier and Coefficient of Variation	50
Data Persistence Test.....	51
SPC-1C Workload Generator Input Parameters.....	51
Data Persistence Test Results File	51
Data Persistence Test Results.....	52
Priced Storage Configuration Availability Date.....	53
Anomalies or Irregularities	53
Appendix A: SPC-1C Glossary	54
“Decimal” (<i>powers of ten</i>) Measurement Units.....	54
“Binary” (<i>powers of two</i>) Measurement Units.....	54
SPC-1C Data Repository Definitions	54
SPC-1C Data Protection Levels.....	55
SPC-1C Test Execution Definitions.....	55
I/O Completion Types	57
SPC-1C Test Run Components	57
Appendix B: Customer Tunable Parameters and Options.....	58
Raid-5 Volume Parameters/Options.....	58
Disk Enclosure Backplane Configuration.....	58
Appendix C: Tested Storage Configuration (TSC) Creation	60
Create RAID-5 Volumes	60
Clear RAID volumes	60
Get disk list	60
Create the RAID-5 Volumes	60
Configure ASU-1, ASU-2, and ASU-3 from the RAID-5 Volumes.....	61
Create an alignment partition.....	61
Configure ASU-3	61
Configure ASU-2	62
Configure ASU-1	62

Remove alignment partition.....	62
Disable Volume Initialization.....	62
Appendix D: SPC-1C Workload Generator Storage Commands and Parameters	64
metrics.txt	64
repeat1.txt	64
repeat2.txt	64
persist1.txt	65
persist2.txt	65
Appendix E: SPC-1C Workload Generator Input Parameters	66
Primary Metrics Test, Repeatability Test, and Persistence Test Run 1	66
Cache Flush	66
Persistence Test Run 2.....	66
Appendix F: Third-Party Quotes	67
LSI MegaRAID SAS 8888ELP.....	67
Seagate Savvio™ 15K, 36 GB SAS Disk Drives	68
AIC XJ SA26-224R Disk Enclosure	69
External SAS Cables	69
External SAS Cables	70

AUDIT CERTIFICATION



Charles Gimarc
LSI Corporation
4420 ArrowsWest Dr.
Colorado Springs, CO 80907

December 8, 2008

The SPC Benchmark 1C™ results listed below for the LSI MegaRAID SAS 8888ELP (24 disks) were produced in compliance with the SPC Benchmark 1C™ V1.1 Onsite Audit requirements.

SPC Benchmark 1C™ V1.1 Results	
Tested Storage Product: LSI MegaRAID SAS 8888ELP (24 disks)	
Metric	Reported Result
SPC-1C IOPS™	4,234.44
Total ASU Capacity	293,618 GB
Data Protection Level	Protected (RAID-5)
Total Price – Priced Storage Configuration	\$9,597.13

The following SPC Benchmark 1C™ Audit requirements were reviewed and found compliant with V1.1 of the SPC Benchmark 1C™ specification:

- A Letter of Good Faith, signed by a senior executive.
- The following Data Repository storage items were verified by physical inspection and information supplied by LSI Corporation:
 - ✓ Physical Storage Capacity and requirements.
 - ✓ Configured Storage Capacity and requirements.
 - ✓ Addressable Storage Capacity and requirements.
 - ✓ Capacity of each Logical Volume and requirements.
 - ✓ Capacity of each Application Storage Unit (ASU) and requirements.
- An appropriate diagram of the Benchmark Configuration (BC)/Tested Storage Configuration (TSC).
- Physical verification of the components to match the above diagram.

Storage Performance Council
643 Bair Island Road, Suite 103
Redwood City, CA 94062
AuditService@storageperformance.org
650.556.9384

AUDIT CERTIFICATION (CONT.)

LSI MegaRAID SAS 8888ELP (24 disks)
SPC-1C Audit Certification

Page 2

- Listings and commands to configure the Benchmark Configuration/Tested Storage Configuration, including customer tunable parameters that were changed from default values.
- SPC-1C Workload Generator commands and parameters used for the audited SPC-1C Test Runs.
- The following Host System requirements were verified by physical inspection and information supplied by LSI Corporation:
 - ✓ The type of Host System including the number of processors and main memory.
 - ✓ The presence and version number of the SPC-1C Workload Generator on the Host System.
 - ✓ The TSC boundary within the Host System.
- The Test Results Files and resultant Summary Results Files for each of following were authentic, accurate, and compliant with all of the requirements and constraints of Clauses 4, 5 and 6 of the SPC-1C Benchmark Specification:
 - ✓ Data Persistence Test
 - ✓ Sustainability Test Phase
 - ✓ IOPS Test Phase
 - ✓ Response Time Ramp Test Phase
 - ✓ Repeatability Test
- There were no differences between the Tested Storage Configuration (TSC) used for the benchmark and Priced Storage Configuration.
- The submitted pricing information met all of the requirements and constraints of Clause 9 of the SPC-1C Benchmark Specification.
- The Full Disclosure Report (FDR) met all of the requirements in Clause 10 of the SPC-1C Benchmark Specification.
- This successfully audited SPC measurement is not subject to an SPC Confidential Review.

Audit Notes:

There were no audit notes or exceptions.

Respectfully,

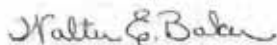

Walter E. Baker
SPC Auditor

Storage Performance Council
643 Bair Island Road, Suite 103
Redwood City, CA 94062
AuditService@storageperformance.org
650.556.9384

LETTER OF GOOD FAITH

LSI Corporation
1621 Barber Lane
Milpitas, CA 95035

1 800 372 2447
lsi.com



Date: *October 28, 2008*
From: *Kelly Bryant*
To: *Walter Baker*
Subject: *SPC-1C Letter of Good Faith for the LSI MegaRAID SAS 8888ELP (24 Disk)*

LSI Corporation is the SPC-1C Test Sponsor of the above listed product. To the best of our knowledge and belief, the required SPC-1C benchmark results and materials we have submitted for that product are complete, accurate, and in full compliance with V1.1 of the SPC-1C benchmark specification.

In addition, we have reported any items in the Benchmark Configuration and execution of the benchmark necessary to reproduce the reported results even if the items are not explicitly required to be disclosed by the above SPC-1C benchmark specification.

Signed

10/17/08

Kelly Bryant

Date

Director, Direct Attached Storage
Engenio Storage Group

LSI Corporation
4165 Shackleford Rd,
Norcross, GA 30093

EXECUTIVE SUMMARY

Test Sponsor and Contact Information

Test Sponsor and Contact Information	
Test Sponsor Primary Contact	LSI Corporation – http://www.lsi.com Charles Gimarc – charles.gimarc@lsi.com 4420 ArrowsWest Dr. Colorado Spring, CO 80907 Phone: (719) 533-7427 FAX: (719) 533-7183
Test Sponsor Alternate Contact	LSI Corporation – http://www.lsi.com Mark Regester – mark.regester@lsi.com 3718 N. Rock Road Wichita, KS 67226 Phone: (316) 636-8340 FAX: (316) 636-8554
Auditor	Storage Performance Council – http://www.storageperformance.org Walter E. Baker – AuditService@StoragePerformance.org 643 Bair Island Road, Suite 103 Redwood City, CA 94063 Phone: (650) 556-9384 FAX: (650) 556-9385

Revision Information and Key Dates

Revision Information and Key Dates	
SPC-1C Specification revision number	V1.1
SPC-1C Workload Generator revision number	V1.0
Date Results were first used publicly	December 10, 2008
Date the FDR was submitted to the SPC	December 10, 2008
Date the TSC is available for shipment to customers	currently available
Date the TSC completed audit certification	December 8, 2008

Tested Storage Product (TSP) Description

The MegaRAID SAS 8888ELP, a second generation SAS RAID product, addresses the business demands of data availability, data protection, and performance. The adapter features the LSI SAS 1078, an I/O storage engine that performs data protection, data checking, and data restoration. The adapter employs selectable connectors, enabling it to serve three deployment scenarios: two internal, two external, or one of each. Up to 240 disks can be attached, all SAS, all SATA, or a combination of both. A RAID data cache of 512 MB is available with two battery backup options. The adapter uses a 500 MHz Power PC embedded processor, 667 MHz data cache, 8 lanes of PCI express, and eight 3 Gb/s SAS links to provide class-leading I/O performance. RAID levels 0, 1, 5, and 6 are configurable, as are RAID spans 10, 50, and 60.

Summary of Results

SPC-1C Results	
Tested Storage Configuration (TSC) Name: LSI MegaRAID SAS 8888ELP (24 disks)	
Metric	Reported Result
SPC-1C IOPS™	4,234.44
Total ASU Capacity	293.618 GB
Data Protection Level	Protected (RAID-5)
Total Price	\$9,597.13

SPC-1C IOPS™ represents the maximum I/O Request Throughput at the 100% load point.

Total ASU (Application Storage Unit) Capacity represents the total storage capacity read and written in the course of executing the SPC-1C benchmark.

A **Data Protection Level of Protected (RAID-5)** provides data protection by distributing check data corresponding to user data across multiple disks in the form of bit-by-bit parity.

Storage Capacities and Relationships

The Tested Storage Configuration (TSC) must be configured so that there is either no Unused Storage or that the sum of Total ASU Capacity plus storage required for data protection equals 50% (+1 GiB) of the Physical Storage Capacity. This configuration meets the 50% requirement as documented below:

$$880.894 \text{ GB (Physical Storage Capacity)} * 0.5 = 440.447 \text{ GB}$$

$$293.618 \text{ GB (Total ASU Capacity)} + 146.809 \text{ GB (data protection)} = 440.427 \text{ GB}$$

The following diagram documents the various storage capacities, used in this benchmark, and their relationships.

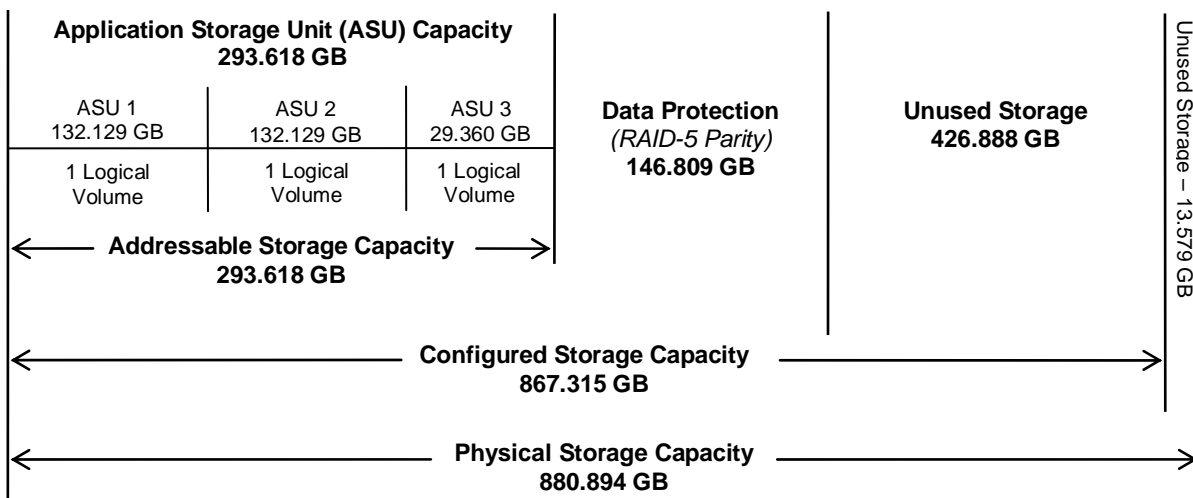

Response Time – Throughput Curve

The Response Time-Throughput Curve illustrates the Average Response Time (milliseconds) and I/O Request Throughput at 100%, 95%, 90%, 80%, 50%, and 10% of the workload level used to generate the SPC-1C IOPS™ metric.

The Average Response Time measured at any of the above load points cannot exceed 30 milliseconds or the benchmark measurement is invalid.

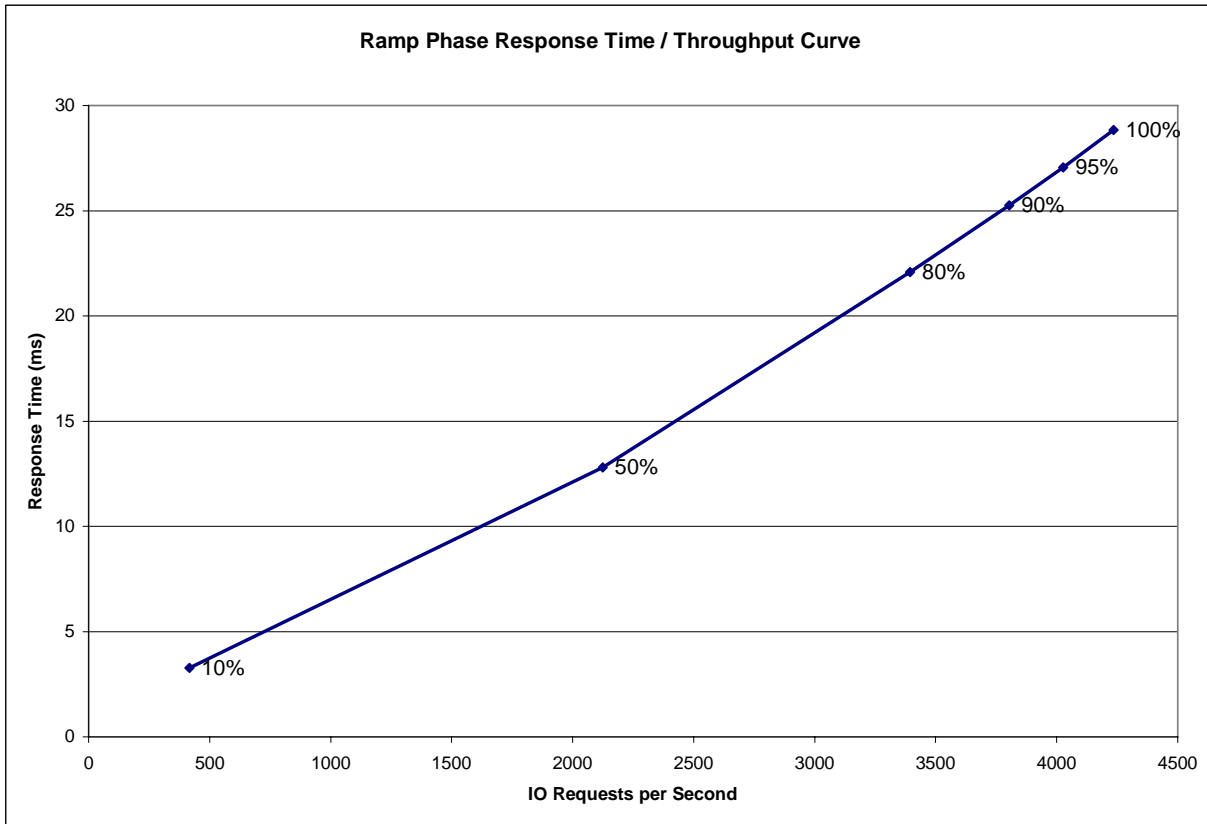

Response Time – Throughput Data

	10% Load	50% Load	80% Load	90% Load	95% Load	100% Load
I/O Request Throughput	416.69	2,124.08	3,394.49	3,803.27	4,025.56	4,234.44
Average Response Time (ms):						
All ASUs	3.27	12.80	22.09	25.26	27.06	28.83
ASU-1	4.00	14.10	24.29	27.69	29.71	31.56
ASU-2	4.90	21.44	37.75	43.72	46.40	50.09
ASU-3	1.02	6.27	10.57	12.01	12.92	13.72
Reads	7.03	25.05	42.77	48.71	52.19	55.54
Writes	0.81	4.82	8.63	9.96	10.64	11.45

Tested Storage Configuration Pricing (*Priced Storage Configuration*)

Component Description	Part Number	Qty	Price	Extd Price
MegaRAID Adapter	SAS 8888ELP	1	789.99	789.99
AIC 24-disk Enclosure	XJ-SA26-224R	1	2,087.14	2,087.14
Seagate Savvio 15K.1 disk	ST936751SS	24	276.00	6,624.00
External mini SAS Cable	SA-8888-1m	2	48.00	96.00
			Total Cost	9,597.13

Differences between the Tested Storage Configuration (TSC) and Priced Storage Configuration

There were no differences between the Tested Storage Configuration and the Priced Storage Configuration

Benchmark Configuration/Tested Storage Configuration Diagram

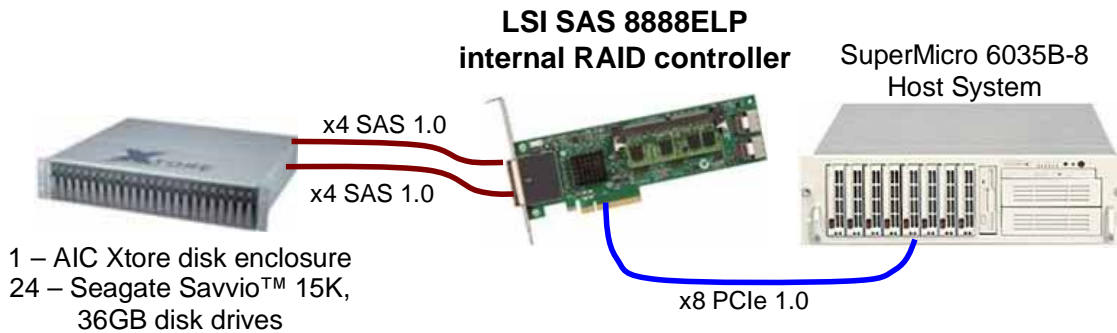

Benchmark Configuration/Tested Storage Configuration Components

Host System:	Tested Storage Configuration (TSC):
SuperMicro 6035B-8 2 – 2.66 GHz Intel Xeon x5355 processors 32+32 KB L1 cache per core 4 MB L2 cache per die	1 – LSI MegaRAID SAS 8888ELP internal RAID controller with: 512 MB cache 1 - x8 PCIe 1.0 host connect 2 - x8 3 Gb/s SAS 1.0 disk connect
8 GB main memory	
Windows 2003 Enterprise Edition	1 – AIC Xtore XJ-SA260224R-s disk enclosure
PCIe 1.0	24 – Seagate Savvio™ 15K, 36 GB SAS disks
	2 – x4 external SAS cables

In each of the following sections of this document, the appropriate Full Disclosure Report requirement, from the SPC-1C benchmark specification, is stated in italics followed by the information to fulfill the stated requirement.

CONFIGURATION INFORMATION

Benchmark Configuration (BC)/Tested Storage Configuration (TSC) Diagram

Clause 10.4.5.10

The Executive Summary will contain a one page BC/TSC diagram that illustrates all major components of the BC/TSC.

The Benchmark Configuration (BC)/Tested Storage Configuration (TSC) is illustrated on page 14 (*Benchmark Configuration/Tested Storage Configuration Diagram*).

Host System and Tested Storage Configuration

Clause 10.4.5.11

The Executive Summary will contain a table that lists the major components of each Host System and the Tested Storage Configuration (TSC).

The table listing the major components of each Host System and the Tested Storage Configuration may be found on page 14 (*Benchmark Configuration/Tested Storage Configuration Components*).

Customer Tunable Parameters and Options

Clause 10.4.6.1

All Benchmark Configuration (BC) components with customer tunable parameters and options that have been altered from their default values must be listed in the Full Disclosure Report (FDR). The FDR entry for each of those components must include both the name of the component and the altered value of the parameter or option. If the parameter name is not self-explanatory to a knowledgeable practitioner, a brief description of the parameter's use must also be included in the FDR entry.

“Appendix B: Customer Tunable Parameters and Options” on page 58 contains the customer tunable parameters and options that have been altered from their default values for this benchmark.

Tested Storage Configuration (TSC) Description

Clause 9.2.4.5.2

The FDR must include sufficient information to recreate the logical representation of the TSC. In addition to customer tunable parameters and options (Clause 10.4.6.1), that information must include, at a minimum:

- *A diagram and/or description of the following:*
 - *All physical components that comprise the TSC. Those components are also illustrated in the BC Configuration Diagram in Clause 10.4.5.10.*

- *The logical representation of the TSC, configured from the above components that will be presented to the Workload Generator.*
- *Listings of scripts used to create the logical representation of the TSC.*
- *If scripts were not used, a description of the process used with sufficient detail to recreate the logical representation of the TSC.*

“Appendix C: Tested Storage Configuration (TSC) Creation” on page 60 contains the detailed information that describes how to create and configure the logical TSC.

SPC-1C Workload Generator Storage Configuration

Clause 10.4.6.3

The Full Disclosure Report will include all SPC-1C Workload Generator storage configuration commands and parameters used in the SPC-1C benchmark measurements.

The SPC-1C Workload Generator storage configuration commands and parameters for this measurement appear in “Appendix D: SPC-1C Workload Generator Storage Commands and Parameters” on page 64.

SPC-1C DATA REPOSITORY

This portion of the Full Disclosure Report presents the detailed information that fully documents the various SPC-1C storage capacities and mappings used in the Tested Storage Configuration. “SPC-1C Data Repository Definitions” on page 54 contains definitions of terms specific to the SPC-1C Data Repository.

Storage Capacities and Relationships

Clause 10.4.7.1

Two tables and an illustration documenting the storage capacities and relationships of the SPC-1C Storage Hierarchy (Clause 2.1) shall be included in the FDR.

SPC-1C Storage Capacities

SPC-1C Storage Capacities		
Storage Hierarchy Component	Units	Capacity
Total ASU Capacity	Gigabytes (GB)	293.618
Addressable Storage Capacity	Gigabytes (GB)	293.618
Configured Storage Capacity	Gigabytes (GB)	867.315
Physical Storage Capacity	Gigabytes (GB)	880.894
Data Protection (<i>Protected, RAID-5 parity</i>)	Gigabytes (GB)	146.809
Required Storage	Gigabytes (GB)	0.000
Global Storage Overhead	Gigabytes (GB)	0.000
Total Unused Storage	Gigabytes (GB)	440.467

SPC-1C Storage Hierarchy Ratios

	Addressable Storage Capacity	Configured Storage Capacity	Physical Storage Capacity
Total ASU Capacity	100.00%	33.85%	33.333%
Required for Data Protection)		16.93%	16.67%
Addressable Storage Capacity		33.85%	33.33%
Required Storage		0.00%	0.00%
Configured Storage Capacity			98.46%
Global Storage Overhead			0.00%
Unused Storage:			
Addressable	0.00%		
Configured		49.22%	
Physical			1.54%

The Physical Storage Capacity consisted of 880.894 GB distributed over 24 disk drives each with a formatted capacity of 36.704 GB. There was 13.579 GB (1.54%) of Unused Storage within the Physical Storage Capacity. Global Storage Overhead consisted of 0.000 GB (0.00%) of Physical Storage Capacity. There was 426.888 GB (49.22%) of Unused Storage within the Configured Storage Capacity. The Total ASU Capacity utilized 100% of the Addressable Storage Capacity resulting in 0.000 GB (0.00%) of Unused Storage within the Addressable Storage Capacity.

SPC-1C Storage Capacities and Relationships Illustration

The various storage capacities configured in the benchmark result are illustrated below (not to scale).

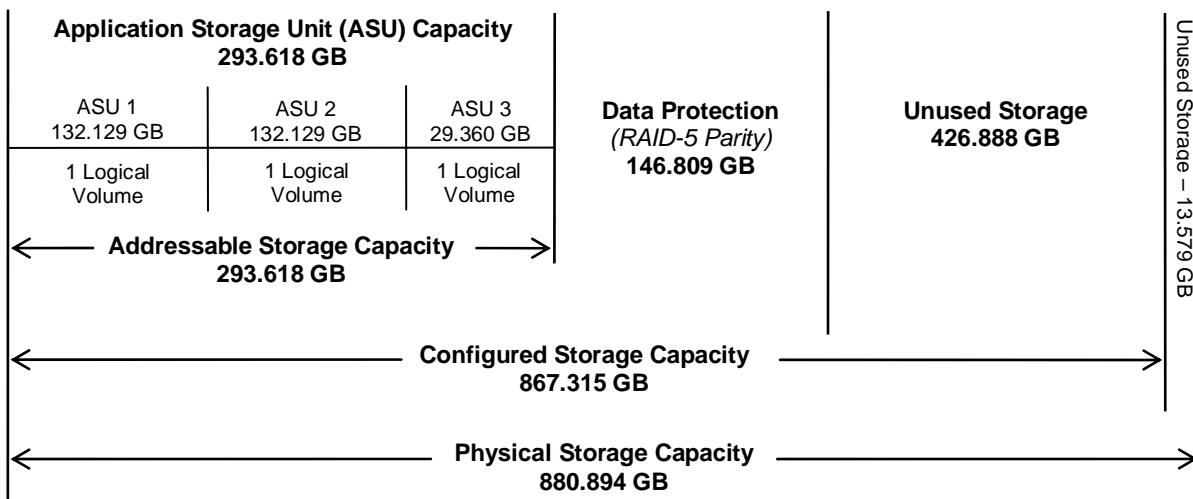

Logical Volume Capacity and ASU Mapping

Clause 10.4.7.2

A table illustrating the capacity of each ASU and the mapping of Logical Volumes to ASUs shall be provided in the FDR. ... Logical Volumes shall be sequenced in the table from top to bottom per its position in the contiguous address space of each ASU. The capacity of each Logical Volume shall be stated. ... In conjunction with this table, the Test Sponsor shall provide a complete description of the type of data protection (see Clause 2.7) used on each Logical Volume.

Logical Volume Capacity and Mapping		
ASU-1 (132.129 GB)	ASU-2 (132.129 GB)	ASU-3 (29.360 GB)
1 Logical Volume 132.129 GB per Logical Volume (132.129 GB used per Logical Volume)	1 Logical Volume 132.129 GB per Logical Volume (132.129 GB used per Logical Volume)	1 Logical Volume 29.360 GB per Logical Volume (29.360 GB used per Logical Volume)

The Data Protection Level used for all Logical Volumes was “Unprotected” as described on page 11. See “ASU Configuration” in the [IOPS Test Results File](#) for more detailed configuration information.

SPC-1C BENCHMARK EXECUTION RESULTS

This portion of the Full Disclosure Report documents the results of the various SPC-1C Tests, Test Phases, and Test Runs. “SPC-1C Test Execution Definitions” on page 55 contains definitions of terms specific to the SPC-1C Tests, Test Phases, and Test Runs.

Clause 6.4.2

The Tests must be executed in the following sequence: Primary Metrics, Repeatability, and Data Persistence. That required sequence must be uninterrupted from the start of Primary Metrics to the completion of Persistence Test Run 1.

Uninterrupted means the Benchmark Configuration shall not be power cycled, restarted, disturbed, altered, or adjusted during the selected Test sequence. If the selected Test sequence is interrupted, the SPC-1C measurement is invalid. This does not apply to the interruption caused by the Host System/TSC power cycle between Persistence Test Run 1 and Persistence Test Run 2.

SPC-1C Tests, Test Phases, and Test Runs

The SPC-1C benchmark consists of the following Tests, Test Phases, and Test Runs:

- **Primary Metrics Test**
 - Sustainability Test Phase and Test Run
 - IOPS Test Phase and Test Run
 - Response Time Ramp Test Phase
 - 95% of IOPS Test Run
 - 90% of IOPS Test Run
 - 80% of IOPS Test Run
 - 50% of IOPS Test Run
 - 10% of IOPS Test Run (LRT)
- **Repeatability Test**
 - Repeatability Test Phase 1
 - 10% of IOPS Test Run (LRT)
 - IOPS Test Run
 - Repeatability Test Phase 2
 - 10% of IOPS Test Run (LRT)
 - IOPS Test Run
- **Data Persistence Test**
 - Data Persistence Test Run 1
 - Data Persistence Test Run 2

Each Test is an atomic unit that must be executed from start to finish before any other Test, Test Phase, or Test Run may be executed.

The results from each Test, Test Phase, and Test Run are listed below along with a more detailed explanation of each component.

Primary Metrics Test – Sustainability Test Phase

Clause 6.4.3.2

The Sustainability Test Phase has exactly one Test Run and shall demonstrate the maximum sustainable I/O Request Throughput within a continuous one (1) hour Measurement Interval.

Clause 6.4.3.2.6

The computed I/O Request Throughput of the Sustainability Test Run must be no less than 95% of the reported SPC-1C IOPS™ result or the Test Run is invalid.

Clause 6.4.3.2.7

The Average Response Time, as defined in Clause 0, will be computed and reported for the Sustainability Test Run and cannot exceed 30 milliseconds. If the Average Response Time exceeds that 30-millisecond constraint, the Test Run is invalid.

Clause 10.4.8.1

For the Sustainability Test Phase the FDR shall contain:

- 1. A Data Rate Distribution graph and data table.*
- 2. I/O Request Throughput Distribution graph and data table.*
- 3. A Response Time Frequency Distribution graph and table.*
- 4. An Average Response Time Distribution graph and table.*
- 5. The human readable Test Run Results File produced by the Workload Generator (may be included in an appendix).*
- 6. A listing or screen image of all input parameters supplied to the Workload Generator (may be included in an appendix).*
- 7. The Measured Intensity Multiplier for each I/O stream.*
- 8. The variability of the Measured Intensity Multiplier, as defined in Clause 5.3.13.3.*

SPC-1C Workload Generator Input Parameters

The SPC-1C Workload Generator input parameters for the Sustainability, IOPS, Response Time Ramp, Repeatability, and Persistence Test Runs are documented in “Appendix E: SPC-1C Workload Generator Input Parameters” on Page 66.

Sustainability Test Results File

A link to the test results file generated from the Sustainability Test Run is listed below.

[Sustainability Test Results File](#)

Sustainability – Data Rate Distribution Data (MB/second)

Ramp-Up/Start-Up	Start	Stop	Interval	Duration
	9:47:48	9:50:48	0-2	0:03:00
Measurement Interval	9:50:48	10:50:48	3-62	1:00:00

Interval	All ASUs	ASU1	ASU2	ASU3	Interval	All ASUs	ASU1	ASU2	ASU3
0	34.90	13.48	3.78	17.64	32	34.81	13.48	3.72	17.61
1	34.91	13.53	3.70	17.68	33	34.87	13.55	3.72	17.60
2	34.90	13.60	3.75	17.55	34	34.96	13.60	3.74	17.62
3	34.79	13.51	3.70	17.58	35	35.00	13.62	3.73	17.64
4	34.98	13.58	3.75	17.66	36	34.85	13.60	3.74	17.51
5	34.86	13.55	3.68	17.63	37	34.77	13.57	3.73	17.47
6	34.90	13.60	3.69	17.61	38	34.67	13.46	3.73	17.47
7	34.98	13.49	3.80	17.69	39	34.88	13.66	3.69	17.54
8	34.76	13.49	3.67	17.60	40	34.85	13.46	3.73	17.66
9	34.57	13.51	3.71	17.35	41	34.72	13.59	3.73	17.40
10	35.00	13.55	3.74	17.71	42	34.67	13.47	3.68	17.52
11	34.96	13.55	3.73	17.68	43	34.75	13.54	3.73	17.48
12	34.80	13.61	3.76	17.44	44	34.95	13.53	3.71	17.70
13	35.00	13.48	3.79	17.73	45	35.10	13.66	3.73	17.71
14	34.84	13.51	3.76	17.56	46	34.88	13.56	3.73	17.59
15	35.03	13.59	3.70	17.73	47	34.94	13.58	3.73	17.64
16	34.97	13.67	3.69	17.62	48	34.64	13.43	3.76	17.45
17	35.03	13.54	3.74	17.76	49	34.80	13.55	3.66	17.58
18	34.84	13.54	3.67	17.63	50	34.85	13.53	3.65	17.67
19	34.98	13.66	3.67	17.65	51	35.02	13.60	3.71	17.71
20	34.84	13.53	3.68	17.62	52	34.85	13.55	3.69	17.61
21	35.03	13.49	3.76	17.78	53	34.77	13.56	3.70	17.51
22	35.08	13.58	3.70	17.80	54	34.97	13.62	3.79	17.56
23	34.85	13.52	3.76	17.57	55	34.73	13.42	3.73	17.58
24	35.17	13.64	3.78	17.75	56	34.99	13.47	3.71	17.81
25	34.93	13.61	3.70	17.61	57	34.81	13.56	3.69	17.56
26	34.77	13.52	3.76	17.49	58	35.05	13.64	3.70	17.71
27	34.89	13.59	3.71	17.59	59	34.81	13.46	3.71	17.64
28	34.97	13.64	3.72	17.61	60	34.71	13.54	3.75	17.42
29	34.82	13.59	3.68	17.55	61	34.81	13.52	3.68	17.61
30	34.83	13.60	3.70	17.52	62	33.11	12.86	3.51	16.74
31	34.83	13.65	3.67	17.51					

Sustainability – Data Rate Distribution Graph

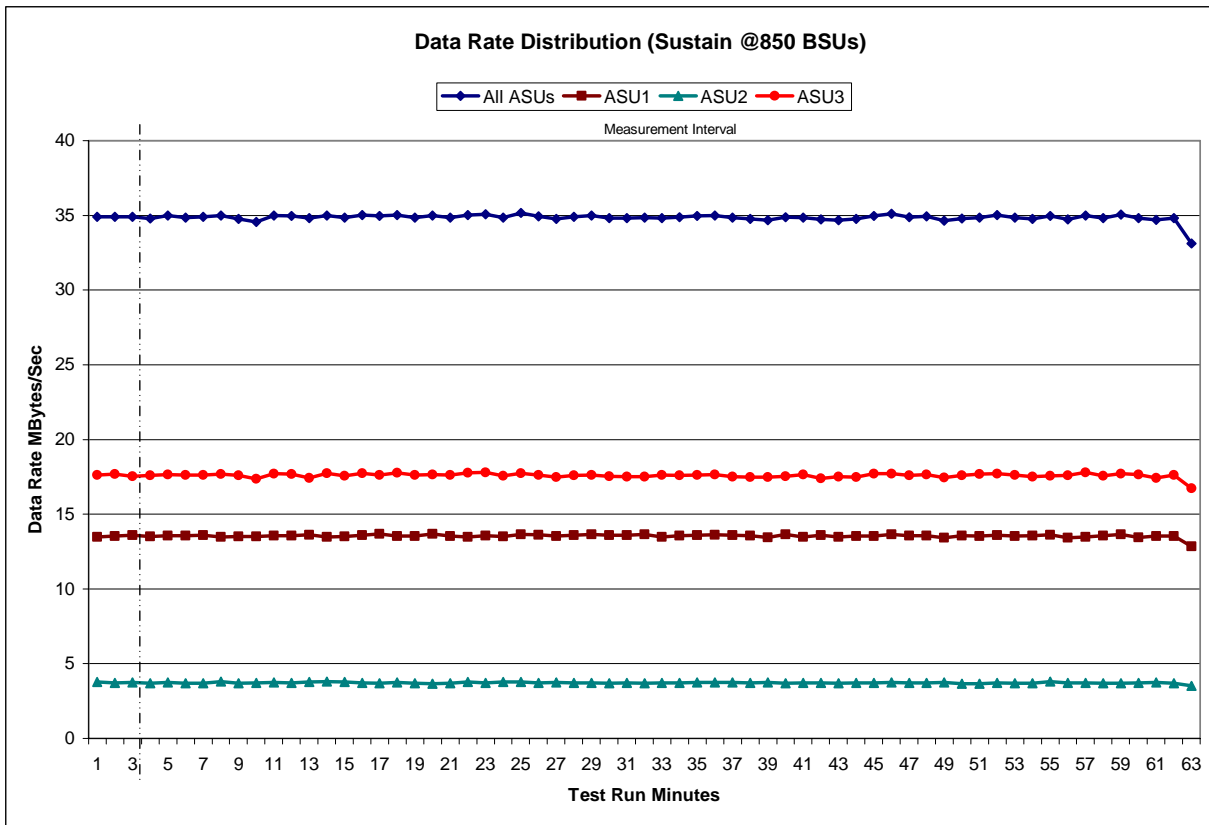

Sustainability – I/O Request Throughput Distribution Data

	Start	Stop	Interval	Duration
Ramp-Up/Start-Up	9:47:48	9:50:48	0-2	0:03:00
Measurement Interval	9:50:48	10:50:48	3-62	1:00:00

Interval	All ASUs	ASU1	ASU2	ASU3	Interval	All ASUs	ASU1	ASU2	ASU3
0	4,243.12	2,523.80	525.00	1,194.32	32	4,243.67	2,525.23	524.25	1,194.18
1	4,238.23	2,522.13	521.27	1,194.83	33	4,244.88	2,529.42	524.05	1,191.42
2	4,267.48	2,543.23	526.85	1,197.40	34	4,256.22	2,539.72	520.93	1,195.57
3	4,249.28	2,534.18	520.75	1,194.35	35	4,257.57	2,542.48	524.25	1,190.83
4	4,253.05	2,535.58	525.53	1,191.93	36	4,253.88	2,538.53	521.27	1,194.08
5	4,257.07	2,539.92	523.25	1,193.90	37	4,254.13	2,535.10	524.77	1,194.27
6	4,251.02	2,537.73	524.38	1,188.90	38	4,240.00	2,525.33	523.30	1,191.37
7	4,239.35	2,522.52	522.27	1,194.57	39	4,245.97	2,534.17	519.18	1,192.62
8	4,244.40	2,532.48	515.58	1,196.33	40	4,244.38	2,530.15	520.18	1,194.05
9	4,238.47	2,529.48	524.55	1,184.43	41	4,234.25	2,532.83	519.80	1,181.62
10	4,250.97	2,530.25	523.22	1,197.50	42	4,238.35	2,526.93	524.63	1,186.78
11	4,250.13	2,527.32	523.22	1,199.60	43	4,243.47	2,533.63	523.45	1,186.38
12	4,254.83	2,536.95	528.18	1,189.70	44	4,255.07	2,534.57	525.62	1,194.88
13	4,252.95	2,529.33	529.57	1,194.05	45	4,257.22	2,541.18	520.35	1,195.68
14	4,248.00	2,529.58	519.07	1,199.35	46	4,251.03	2,537.65	519.87	1,193.52
15	4,265.13	2,540.08	523.77	1,201.28	47	4,251.17	2,535.82	521.05	1,194.30
16	4,249.75	2,533.78	520.17	1,195.80	48	4,234.30	2,520.37	526.02	1,187.92
17	4,253.03	2,530.63	524.43	1,197.97	49	4,243.75	2,532.62	516.98	1,194.15
18	4,244.87	2,527.58	519.57	1,197.72	50	4,246.67	2,530.23	521.90	1,194.53
19	4,258.50	2,540.68	522.72	1,195.10	51	4,256.52	2,539.88	523.10	1,193.53
20	4,252.47	2,535.33	519.67	1,197.47	52	4,243.75	2,529.87	517.12	1,196.77
21	4,253.23	2,528.03	522.00	1,203.20	53	4,252.37	2,538.45	521.53	1,192.38
22	4,259.87	2,537.77	517.75	1,204.35	54	4,268.65	2,548.92	527.67	1,192.07
23	4,251.87	2,534.27	524.32	1,193.28	55	4,233.57	2,518.47	520.15	1,194.95
24	4,273.20	2,546.25	527.43	1,199.52	56	4,261.45	2,538.25	523.55	1,199.65
25	4,263.17	2,545.32	520.17	1,197.68	57	4,251.55	2,534.63	521.07	1,195.85
26	4,264.72	2,545.37	525.42	1,193.93	58	4,272.30	2,548.17	521.18	1,202.95
27	4,258.37	2,533.97	525.85	1,198.55	59	4,249.77	2,530.10	520.27	1,199.40
28	4,267.13	2,546.90	524.63	1,195.60	60	4,249.38	2,541.12	522.87	1,185.40
29	4,244.73	2,529.68	524.00	1,191.05	61	4,233.80	2,518.93	522.00	1,192.87
30	4,254.17	2,542.97	521.63	1,189.57	62	4,031.97	2,403.73	495.13	1,133.10
31	4,261.03	2,548.55	522.97	1,189.52	Average	4,247.76	2,532.48	522.06	1,193.22

Sustainability – I/O Request Throughput Distribution Graph

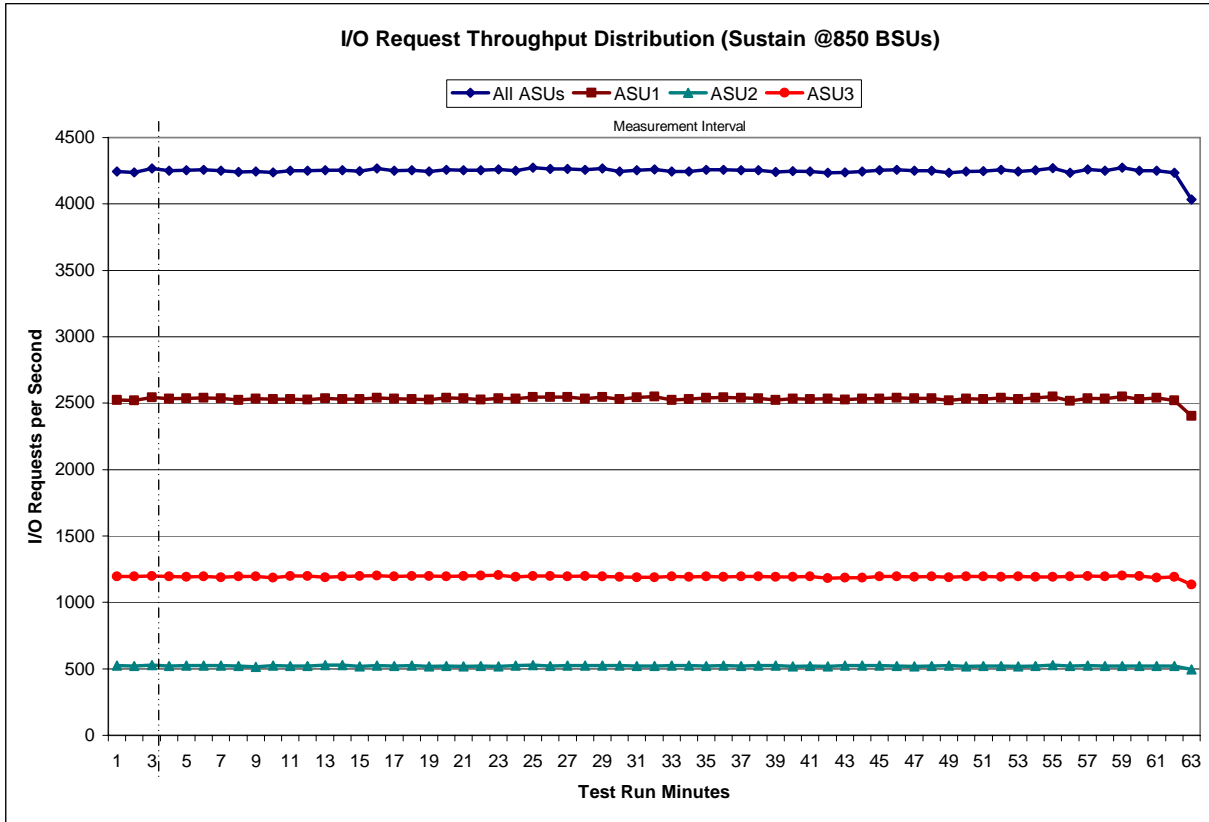

Sustainability – Average Response Time (ms) Distribution Data

	Start	Stop	Interval	Duration					
Ramp-Up/Start-Up	9:47:48	9:50:48	0-2	0:03:00					
Measurement Interval	9:50:48	10:50:48	3-62	1:00:00					

Interval	All ASUs	ASU1	ASU2	ASU3	Interval	All ASUs	ASU1	ASU2	ASU3
0	29.41	32.44	51.42	13.31	32	29.36	32.40	50.79	13.54
1	28.94	31.83	49.98	13.65	33	29.52	32.59	50.91	13.58
2	28.79	31.58	50.37	13.39	34	29.21	32.02	51.27	13.63
3	28.56	31.21	50.52	13.38	35	29.48	32.44	50.49	13.90
4	28.58	31.34	49.62	13.40	36	29.23	32.05	51.32	13.59
5	28.64	31.28	49.85	13.70	37	29.52	32.49	50.97	13.79
6	28.90	31.48	49.75	14.19	38	29.36	32.09	51.54	13.84
7	28.85	31.42	51.17	13.68	39	29.37	32.27	50.98	13.79
8	28.90	31.73	49.93	13.84	40	29.54	32.51	51.12	13.85
9	28.84	31.43	50.26	13.80	41	29.32	32.20	51.02	13.60
10	28.88	31.79	49.93	13.52	42	29.40	32.30	50.76	13.77
11	29.34	32.16	50.78	14.03	43	29.33	32.17	51.25	13.60
12	29.09	31.82	50.77	13.65	44	29.46	32.48	50.49	13.79
13	30.44	33.22	53.93	14.15	45	29.38	32.30	51.69	13.48
14	29.07	31.82	51.57	13.52	46	29.58	32.44	51.40	13.99
15	29.25	32.13	51.23	13.58	47	29.29	32.19	50.36	13.94
16	29.16	32.16	50.77	13.38	48	29.35	32.38	50.25	13.69
17	29.41	32.32	50.64	13.99	49	29.37	32.38	51.03	13.61
18	29.30	32.27	51.21	13.54	50	29.29	32.21	51.29	13.50
19	29.45	32.25	51.25	13.95	51	29.37	32.33	50.77	13.71
20	29.39	32.36	51.09	13.67	52	29.28	32.12	51.90	13.49
21	29.47	32.37	51.41	13.88	53	29.44	32.40	51.01	13.71
22	29.54	32.67	50.84	13.80	54	29.30	32.15	50.79	13.68
23	29.31	32.22	50.60	13.79	55	29.37	32.28	51.17	13.74
24	29.38	32.24	51.23	13.71	56	29.51	32.39	51.25	13.95
25	29.48	32.50	51.13	13.65	57	29.39	32.32	51.36	13.60
26	29.26	32.12	50.68	13.73	58	29.17	32.03	51.02	13.65
27	29.35	32.08	51.35	13.94	59	29.47	32.30	51.46	13.97
28	29.31	32.13	51.76	13.46	60	29.37	32.18	51.22	13.69
29	29.50	32.40	50.65	14.04	61	29.36	32.32	50.93	13.68
30	29.39	32.27	51.38	13.59	62	29.37	32.32	51.01	13.65
31	29.41	32.29	51.30	13.61	Average	29.30	32.18	50.99	13.72

Sustainability – Average Response Time (ms) Distribution Graph

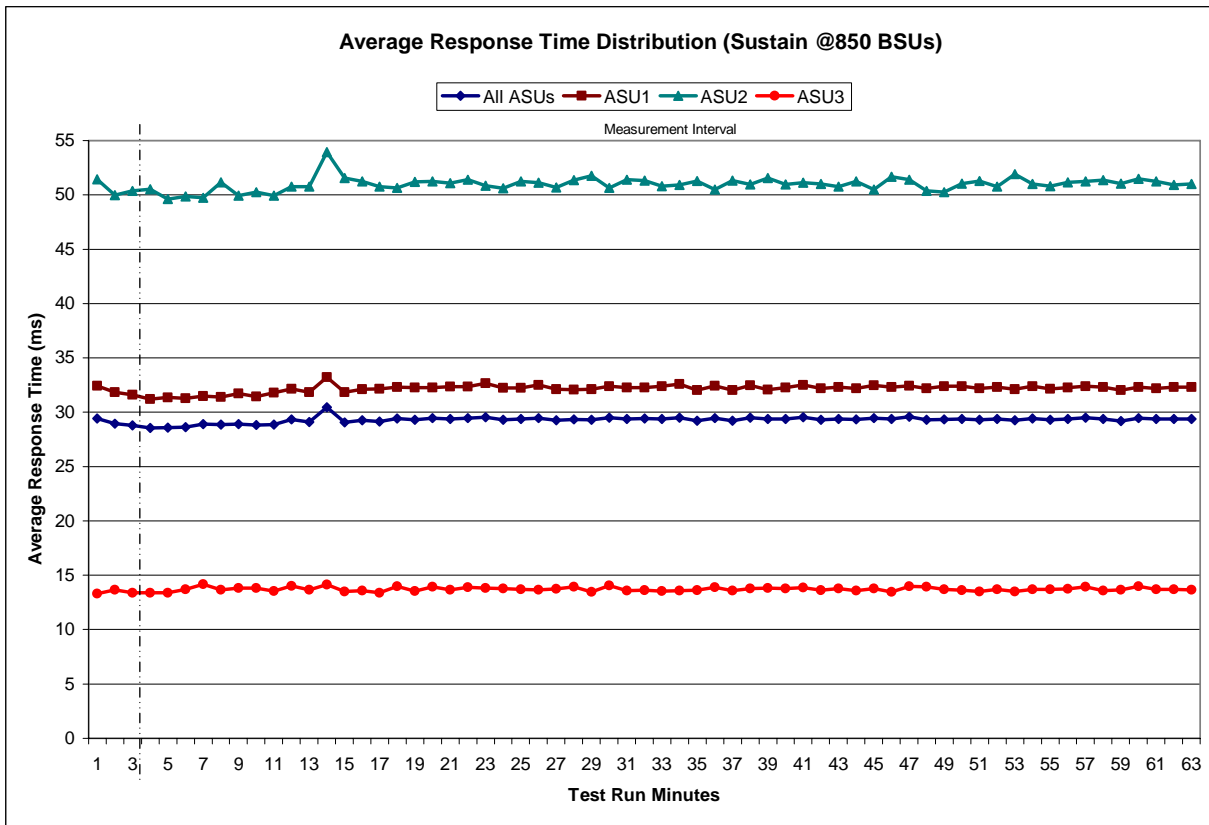

Sustainability – Response Time Frequency Distribution Data

Response Time (ms)	0-0.25	>0.25-0.5	>0.5-0.75	>0.75-1.0	>1.0-1.25	>1.25-1.5	>1.5-1.75	>1.75-2.0
Read	1,874	6,797	6,910	3,637	3,052	6,259	10,853	13,462
Write	1,859,517	2,768,782	1,702,461	439,993	171,351	92,618	55,000	34,764
All ASUs	1,861,391	2,775,579	1,709,371	443,630	174,403	98,877	65,853	48,226
ASU1	875,478	1,200,127	722,003	185,763	74,127	45,006	33,702	27,717
ASU2	200,526	278,436	168,758	43,652	17,330	9,662	6,053	4,244
ASU3	785,387	1,297,016	818,610	214,215	82,946	44,209	26,098	16,265
Response Time (ms)	>2.0-2.5	>2.5-3.0	>3.0-3.5	>3.5-4.0	>4.0-4.5	>4.5-5.0	>5.0-6.0	>6.0-7.0
Read	35,003	86,358	113,559	117,702	123,754	180,461	284,448	286,314
Write	53,758	33,603	29,115	27,251	25,418	24,344	45,550	43,556
All ASUs	88,761	119,961	142,674	144,953	149,172	204,805	329,998	329,870
ASU1	56,537	96,546	118,356	118,542	122,234	170,749	270,830	264,550
ASU2	7,584	8,364	11,485	14,591	15,920	23,351	39,469	46,503
ASU3	24,640	15,051	12,833	11,820	11,018	10,705	19,699	18,817
Response Time (ms)	>7.0-8.0	>8.0-9.0	>9.0-10.0	>10.0-15.0	>15.0-20.0	>20.0-25.0	>25.0-30.0	>30.0
Read	182,617	182,677	137,550	508,552	301,440	252,207	216,553	2,972,952
Write	41,168	39,192	37,202	169,041	149,629	104,727	121,106	1,187,810
All ASUs	223,785	221,869	174,752	677,593	451,069	356,934	337,659	4,160,762
ASU1	171,892	173,916	135,373	512,141	332,014	267,423	245,414	2,896,499
ASU2	34,280	31,179	23,456	94,134	55,940	44,120	40,598	659,777
ASU3	17,613	16,774	15,923	71,318	63,115	45,391	51,647	604,486

Sustainability – Response Time Frequency Distribution Graph

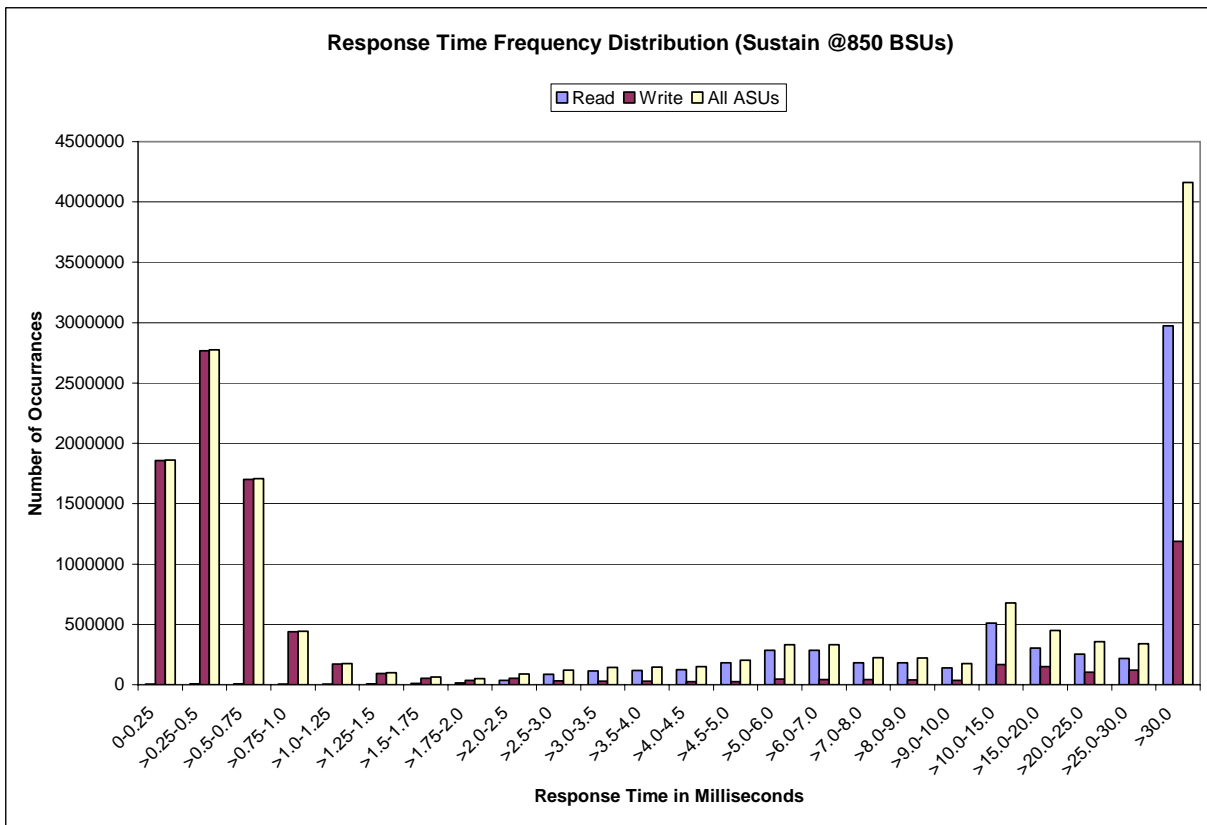

Sustainability – Measured Intensity Multiplier and Coefficient of Variation

Clause 3.4.3

IM – Intensity Multiplier: The ratio of I/Os for each I/O stream relative to the total I/Os for all I/O streams (ASU1-1 – ASU3-1) as required by the benchmark specification.

Clauses 6.1.0

MIM – Measured Intensity Multiplier: The Measured Intensity Multiplier represents the ratio of measured I/Os for each I/O stream relative to the total I/Os measured for all I/O streams (ASU1-1 – ASU3-1).

Clause 6.3.13.3

COV – Coefficient of Variation: This measure of variation for the Measured Intensity Multiplier cannot exceed 0.5.

	ASU1-1	ASU1-2	ASU1-3	ASU1-4	ASU2-1	ASU2-2	ASU2-3	ASU3-1
IM	0.0350	0.2810	0.0700	0.2100	0.0180	0.0700	0.0350	0.2810
MIM	0.0349	0.2811	0.0700	0.2101	0.0179	0.0700	0.0349	0.2809
COV	0.010	0.003	0.008	0.004	0.015	0.007	0.009	0.003

Primary Metrics Test – IOPS Test Phase

Clause 6.4.3.3

The IOPS Test Phase consists of one Test Run at the 100% load point with a Measurement Interval of five (5) minutes. The IOPS Test Phase immediately follows the Sustainability Test Phase without any interruption or manual intervention.

The IOPS Test Run generates the SPC-1C IOPS™ primary metric, which is computed as the I/O Request Throughput for the Measurement Interval of the IOPS Test Run.

The Average Response Time is computed for the IOPS Test Run and cannot exceed 30 milliseconds. If the Average Response Time exceeds the 30 millisecond constraint, the measurement is invalid.

Clause 10.4.8.2

For the IOPS Test Phase the FDR shall contain:

- 1. I/O Request Throughput Distribution (data and graph).*
- 2. Response Time Frequency Distribution (data and graph).*
- 3. Average Response Time Distribution (data and graph).*
- 4. The human readable SPC-1C Test Run Results File produced by the SPC-1C Workload Generator.*
- 5. A listing of all input parameters supplied to the SPC-1C Workload Generator.*
- 6. The Measured Intensity Multiplier for each I/O Stream.*
- 7. The variability of the Measured Intensity Multiplier, as defined in Clause 6.3.13.3.*
- 8. The total number of I/O Requests completed in the Measurement Interval as well as the number of I/O Requests with a Response Time less than or equal to 30 milliseconds and the number of I/O Requests with a Response Time greater than 30 milliseconds.*

SPC-1C Workload Generator Input Parameters

The SPC-1C Workload Generator input parameters for the Sustainability, IOPS, Response Time Ramp, Repeatability, and Persistence Test Runs are documented in “Appendix E: SPC-1C Workload Generator Input Parameters” on Page 66.

IOPS Test Results File

A link to the test results file generated from the IOPS Test Run is listed below.

[IOPS Test Results File](#)

IOPS Test Run – I/O Request Throughput Distribution Data

850 BSUs	Start	Stop	Interval	Duration
<i>Start-Up/Ramp-Up</i>	10:50:51	10:53:51	0-2	0:03:00
<i>Measurement Interval</i>	10:53:51	10:58:51	3-7	0:05:00
60 second intervals	All ASUs	ASU1	ASU2	ASU3
0	4,240.92	2,517.68	526.68	1,196.55
1	4,247.72	2,537.20	520.70	1,189.82
2	4,262.27	2,538.75	522.38	1,201.13
3	4,242.20	2,528.10	524.67	1,189.43
4	4,256.37	2,535.32	524.70	1,196.35
5	4,245.80	2,524.53	522.60	1,198.67
6	4,239.62	2,526.55	522.35	1,190.72
7	4,188.23	2,502.75	513.77	1,171.72
Average	4,234.44	2,523.45	521.62	1,189.38

IOPS Test Run – I/O Request Throughput Distribution Graph

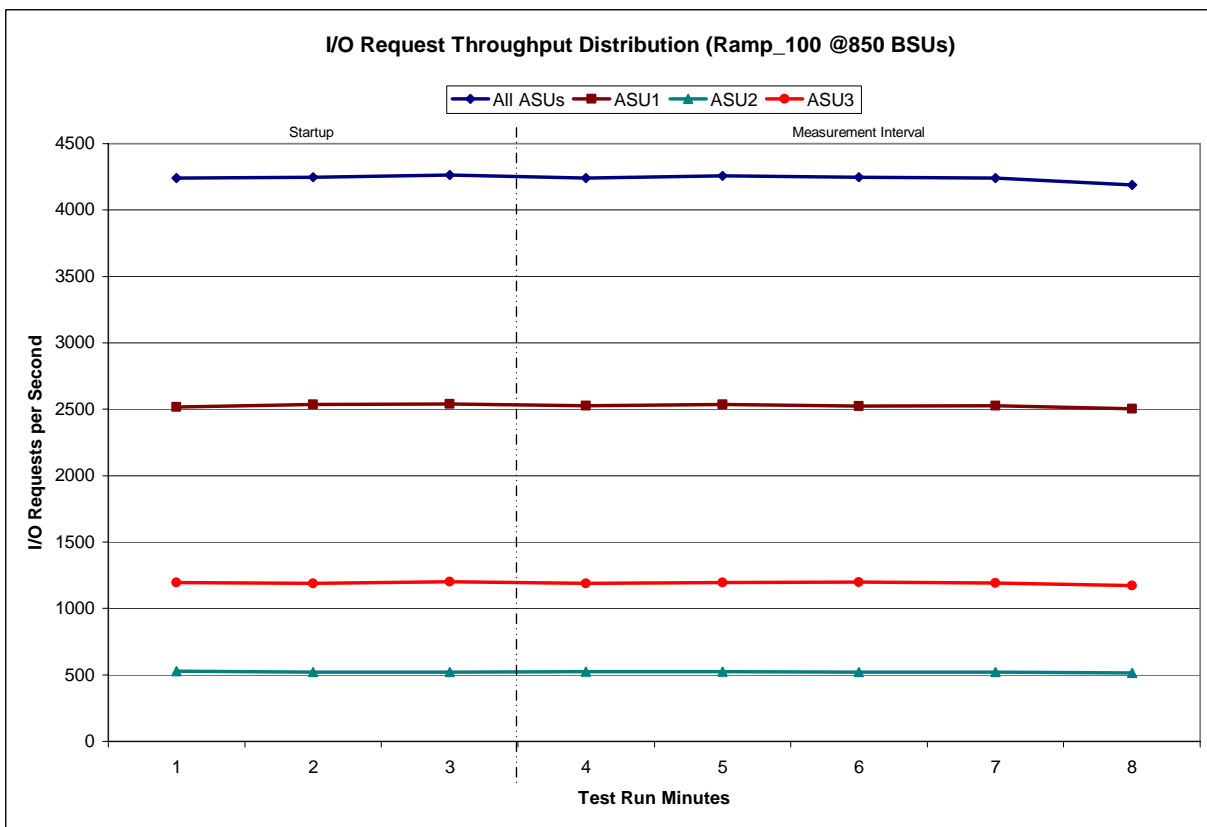

IOPS Test Run – Average Response Time (ms) Distribution Data

850 BSUs	Start	Stop	Interval	Duration
<i>Start-Up/Ramp-Up</i>	10:50:51	10:53:51	0-2	0:03:00
<i>Measurement Interval</i>	10:53:51	10:58:51	3-7	0:05:00
60 second intervals	All ASUs	ASU1	ASU2	ASU3
0	28.69	31.26	50.00	13.89
1	28.59	31.15	49.98	13.78
2	28.68	31.58	49.66	13.43
3	28.77	31.46	50.07	13.64
4	28.63	31.47	49.55	13.44
5	28.98	31.64	50.07	14.16
6	28.76	31.44	50.09	13.71
7	29.02	31.77	50.69	13.65
Average	28.83	31.56	50.09	13.72

IOPS Test Run – Average Response Time (ms) Distribution Graph

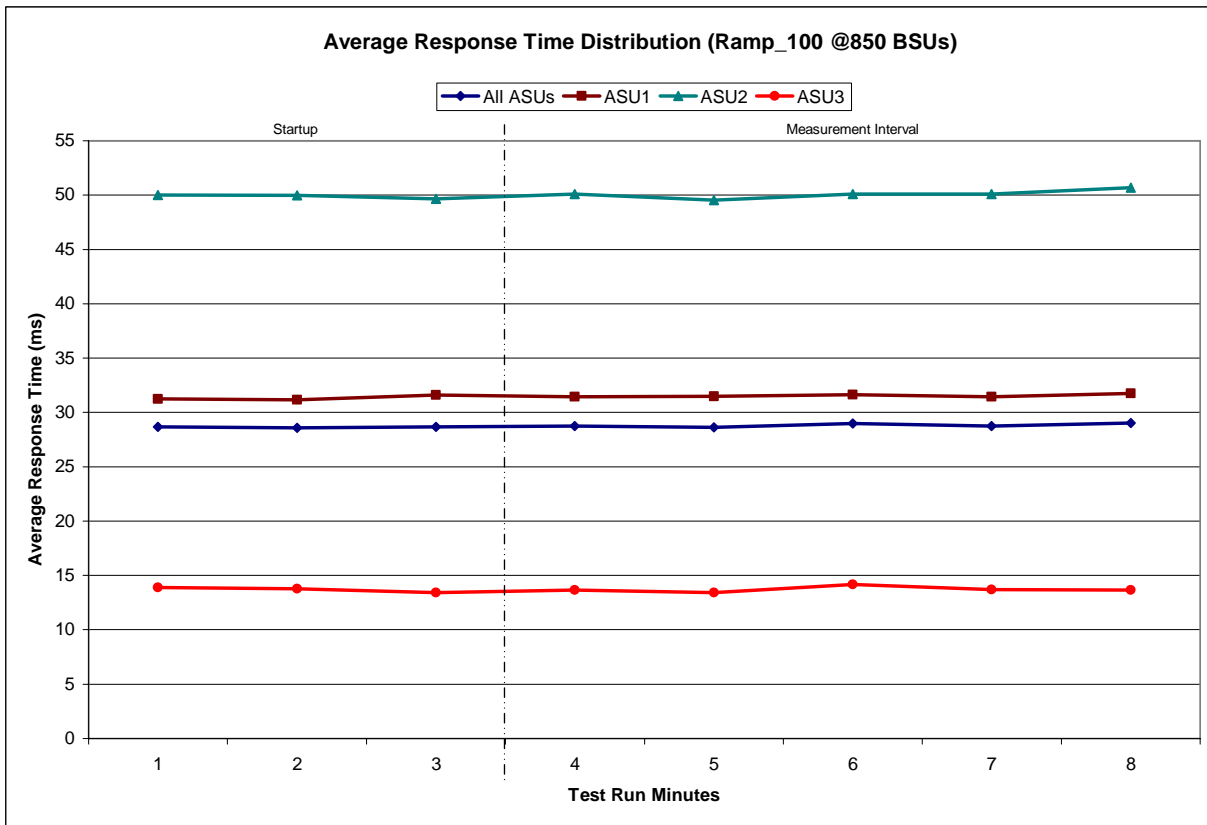

IOPS Test Run – Response Time Frequency Distribution Data

Response Time (ms)	0-0.25	>0.25-0.5	>0.5-0.75	>0.75-1.0	>1.0-1.25	>1.25-1.5	>1.5-1.75	>1.75-2.0
Read	173	594	597	284	254	534	889	1,179
Write	151122	231,889	142,712	35,959	14,472	7,700	4,604	2,878
All ASUs	151295	232,483	143,309	36,243	14,726	8,234	5,493	4,057
ASU1	71359	100,229	60,686	15,289	6,284	3,789	2,818	2,353
ASU2	16346	23,405	14,309	3,597	1,495	805	505	367
ASU3	63590	108,849	68,314	17,357	6,947	3,640	2,170	1,337

Response Time (ms)	>2.0-2.5	>2.5-3.0	>3.0-3.5	>3.5-4.0	>4.0-4.5	>4.5-5.0	>5.0-6.0	>6.0-7.0
Read	3,123	7,478	9,735	10,021	10,775	15,524	24,452	24,545
Write	4,333	2,967	2,466	2,345	2,252	2,039	3,901	3,538
All ASUs	7,456	10,445	12,201	12,366	13,027	17,563	28,353	28,083
ASU1	4,805	8,380	10,146	10,115	10,652	14,767	23,371	22,444
ASU2	637	739	977	1,210	1,391	1,961	3,324	4,109
ASU3	2,014	1,326	1,078	1,041	984	835	1,658	1,530

Response Time (ms)	>7.0-8.0	>8.0-9.0	>9.0-10.0	>10.0-15.0	>15.0-20.0	>20.0-25.0	>25.0-30.0	>30.0
Read	15,387	15,513	11,655	42,192	24,584	20,557	17,642	243,063
Write	3,567	3,349	3,365	14,335	12,567	9,218	10,195	97,810
All ASUs	18,954	18,862	15,020	56,527	37,151	29,775	27,837	340,873
ASU1	14,513	14,776	11,589	42,513	27,201	22,162	20,051	236,743
ASU2	2,929	2,658	1,989	7,915	4,644	3,679	3,331	54,163
ASU3	1,512	1,428	1,442	6,099	5,306	3,934	4,455	49,967

IOPS Test Run –Response Time Frequency Distribution Graph

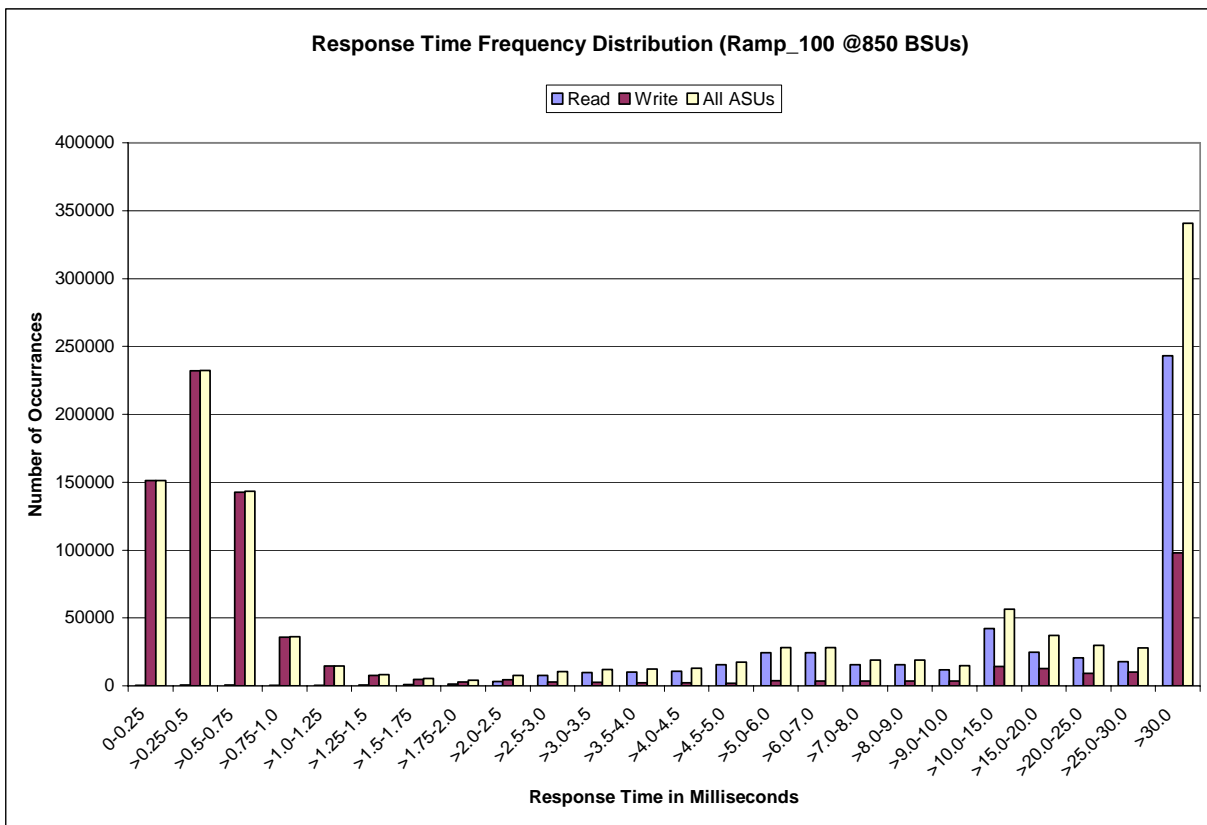

IOPS Test Run – I/O Request Information

I/O Requests Completed in the Measurement Interval	I/O Requests Completed with Response Time = or < 30 ms	I/O Requests Completed with Response Time > 30 ms
1,270,333	929,460	340,873

IOPS Test Run – Measured Intensity Multiplier and Coefficient of Variation

Clause 3.4.3

IM – Intensity Multiplier: The ratio of I/Os for each I/O stream relative to the total I/Os for all I/O streams (ASU1-1 – ASU3-1) as required by the benchmark specification.

Clauses 6.1.0

MIM – Measured Intensity Multiplier: The Measured Intensity Multiplier represents the ratio of measured I/Os for each I/O stream relative to the total I/Os measured for all I/O streams (ASU1-1 – ASU3-1).

Clause 6.3.13.3

COV – Coefficient of Variation: This measure of variation for the Measured Intensity Multiplier cannot exceed 0.5.

	ASU1-1	ASU1-2	ASU1-3	ASU1-4	ASU2-1	ASU2-2	ASU2-3	ASU3-1
IM	0.0350	0.2810	0.0700	0.2100	0.0180	0.0700	0.0350	0.2810
MIM	0.0350	0.2817	0.0697	0.2096	0.0178	0.0704	0.0349	0.2809
COV	0.008	0.004	0.007	0.003	0.017	0.003	0.009	0.003

Primary Metrics Test – Response Time Ramp Test Phase

Clause 6.4.3.4

The Response Time Ramp Test Phase consists of five Test Runs, one each at 95%, 90%, 80%, 50%, and 10% of the load point (100%) used to generate the SPC-1C IOPS™ primary metric. Each of the five Test Runs has a Measurement Interval of five (5) minutes. The Response Time Ramp Test Phase immediately follows the IOPS Test Phase without any interruption or manual intervention.

The five Response Time Ramp Test Runs, in conjunction with the IOPS Test Run (100%), demonstrate the relationship between Average Response Time and I/O Request Throughput for the Tested Storage Configuration (TSC) as illustrated in the response time/throughput curve on page 12.

In addition, the Average Response Time measured during the 10% Test Run is the value for the SPC-1C LRT™ metric. That value represents the Average Response Time of a lightly loaded TSC.

Clause 10.4.8.3

The following content shall appear in the FDR for the Response Time Ramp Phase:

- 1. A Response Time Ramp Distribution graph.*
- 2. The human readable Test Run Results File produced by the SPC-1C C Workload Generator for each Test Run within the Response Time Ramp Test Phase.*
- 3. An Average Response Time Distribution graph and table for the 10% BSU Level Test Run (the SPC-1C LRT™ metric).*
- 4. A listing of all input parameters supplied to the SPC-1C Workload Generator.*

SPC-1C Workload Generator Input Parameters

The SPC-1C Workload Generator input parameters for the Sustainability, IOPS, Response Time Ramp, Repeatability, and Persistence Test Runs are documented in “Appendix E: SPC-1C Workload Generator Input Parameters” on Page 66.

Response Time Ramp Test Results File

A link to each test result file generated from each Response Time Ramp Test Run list listed below.

[95% Load Level](#)

[90% Load Level](#)

[80% Load Level](#)

[50% Load Level](#)

[10% Load Level](#)

Response Time Ramp Distribution (IOPS) Data

The five Test Runs that comprise the Response Time Ramp Phase are executed at 95%, 90%, 80%, 50%, and 10% of the Business Scaling Unit (BSU) load level used to produce the SPC-1C IOPS™ primary metric. The 100% BSU load level is included in the following Response Time Ramp data tables and graphs for completeness.

100% Load Level - 850 BSUs					95% Load Level - 807 BSUs				
Start	Stop	Interval	Duration		Start	Stop	Interval	Duration	
Start-Up/Ramp-Up	10:50:51	10:53:51	0-2	0:03:00	Start-Up/Ramp-Up	10:58:54	11:01:54	0-2	0:03:00
Measurement Interval	10:53:51	10:58:51	3-7	0:05:00	Measurement Interval	11:01:54	11:06:54	3-7	0:05:00
<i>(60 second intervals)</i>					<i>(60 second intervals)</i>				
	All ASUs	ASU-1	ASU-2	ASU-3		All ASUs	ASU-1	ASU-2	ASU-3
0	4,240.92	2,517.68	526.68	1,196.55	0	4,036.88	2,405.80	495.42	1,135.67
1	4,247.72	2,537.20	520.70	1,189.82	1	3,983.72	2,379.72	486.48	1,117.52
2	4,262.27	2,538.75	522.38	1,201.13	2	4,105.93	2,451.35	504.20	1,150.38
3	4,242.20	2,528.10	524.67	1,189.43	3	4,033.07	2,406.42	494.00	1,132.65
4	4,256.37	2,535.32	524.70	1,196.35	4	4,026.90	2,402.42	498.50	1,125.98
5	4,245.80	2,524.53	522.60	1,198.67	5	4,024.18	2,398.97	497.85	1,127.37
6	4,239.62	2,526.55	522.35	1,190.72	6	4,030.47	2,405.42	498.33	1,126.72
7	4,188.23	2,502.75	513.77	1,171.72	7	4,013.20	2,385.63	495.00	1,132.57
Average	4,234.44	2,523.45	521.62	1,189.38	Average	4,025.56	2,399.77	496.74	1,129.06
90% Load Level - 765 BSUs					80% Load Level - 680 BSUs				
Start	Stop	Interval	Duration		Start	Stop	Interval	Duration	
Start-Up/Ramp-Up	11:06:57	11:09:57	0-2	0:03:00	Start-Up/Ramp-Up	11:15:00	11:18:00	0-2	0:03:00
Measurement Interval	11:09:57	11:14:57	3-7	0:05:00	Measurement Interval	11:18:00	11:23:00	3-7	0:05:00
<i>(60 second intervals)</i>					<i>(60 second intervals)</i>				
	All ASUs	ASU-1	ASU-2	ASU-3		All ASUs	ASU-1	ASU-2	ASU-3
0	3,831.90	2,285.72	470.63	1,075.55	0	3,403.33	2,028.30	416.85	958.18
1	3,832.67	2,282.07	474.65	1,075.95	1	3,399.53	2,028.65	418.97	951.92
2	3,811.62	2,274.10	469.72	1,067.80	2	3,407.15	2,032.43	421.57	953.15
3	3,811.58	2,267.12	469.47	1,075.00	3	3,409.40	2,023.00	422.32	964.08
4	3,823.17	2,276.80	470.27	1,076.10	4	3,404.42	2,031.33	416.18	956.90
5	3,814.00	2,270.90	469.18	1,073.92	5	3,384.50	2,020.80	412.23	951.47
6	3,819.32	2,276.43	471.95	1,070.93	6	3,408.85	2,037.85	422.75	948.25
7	3,748.30	2,230.23	465.20	1,052.87	7	3,365.30	2,004.72	411.78	948.80
Average	3,803.27	2,264.30	469.21	1,069.76	Average	3,394.49	2,023.54	417.05	953.90
50% Load Level - 425 BSUs					10% Load Level - 85 BSUs				
Start	Stop	Interval	Duration		Start	Stop	Interval	Duration	
Start-Up/Ramp-Up	11:23:03	11:26:03	0-2	0:03:00	Start-Up/Ramp-Up	11:31:05	11:34:05	0-2	0:03:00
Measurement Interval	11:26:03	11:31:03	3-7	0:05:00	Measurement Interval	11:34:05	11:39:05	3-7	0:05:00
<i>(60 second intervals)</i>					<i>(60 second intervals)</i>				
	All ASUs	ASU-1	ASU-2	ASU-3		All ASUs	ASU-1	ASU-2	ASU-3
0	2,133.58	1,270.52	259.27	603.80	0	425.30	254.15	53.38	117.77
1	2,130.82	1,270.37	263.05	597.40	1	422.15	252.63	52.68	116.83
2	2,122.67	1,262.68	259.18	600.80	2	419.43	249.52	50.93	118.98
3	2,125.60	1,269.67	261.00	594.93	3	425.57	255.35	51.85	118.37
4	2,120.40	1,260.57	261.62	598.22	4	423.53	251.90	52.42	119.22
5	2,138.30	1,275.15	263.22	599.93	5	425.40	253.73	51.52	120.15
6	2,123.33	1,261.03	260.50	601.80	6	429.70	257.28	52.68	119.73
7	2,112.77	1,261.63	259.03	592.10	7	379.27	226.82	45.85	106.60
Average	2,124.08	1,265.61	261.07	597.40	Average	416.69	249.02	50.86	116.81

Response Time Ramp Distribution (IOPS) Graph

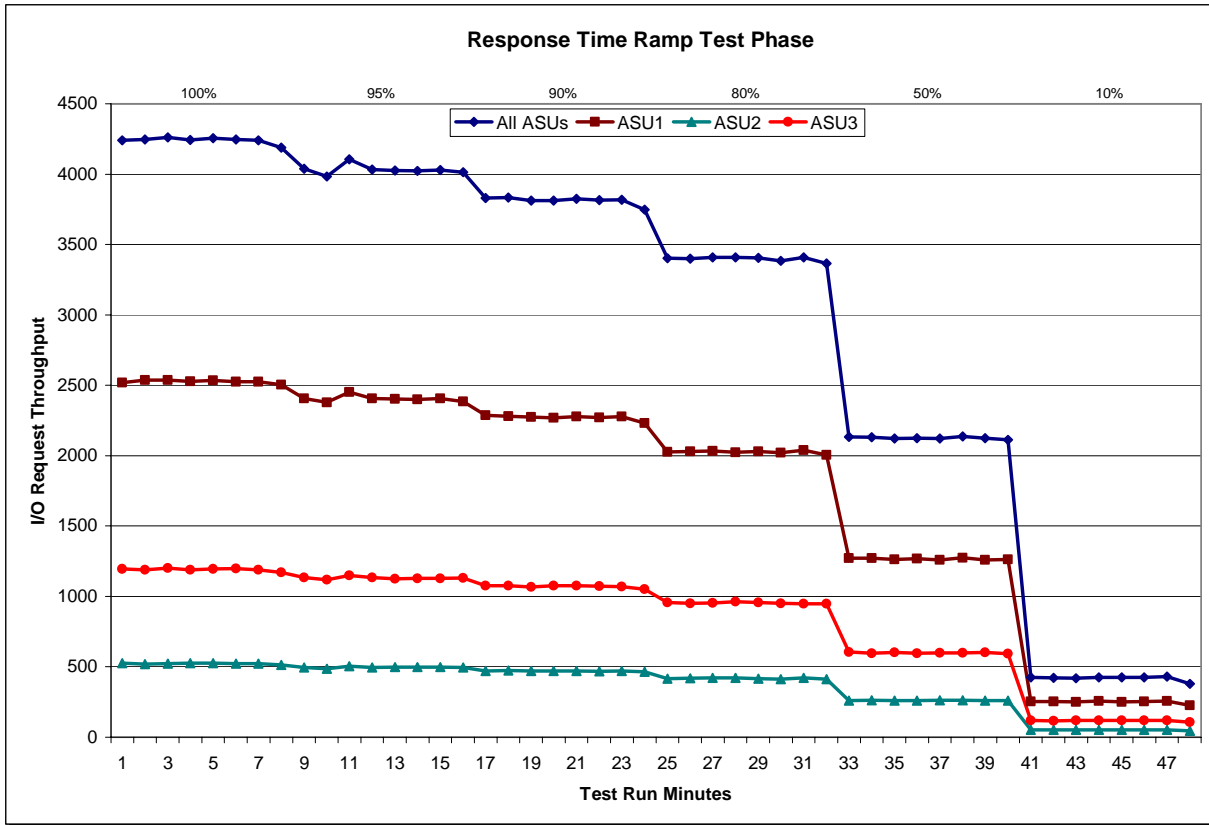

SPC-1C LRT™ Average Response Time (ms) Distribution Data

85 BSUs	Start	Stop	Interval	Duration
<i>Start-Up/Ramp-Up</i>	11:31:05	11:34:05	0-2	0:03:00
<i>Measurement Interval</i>	11:34:05	11:39:05	3-7	0:05:00
60 second intervals	All ASUs	ASU1	ASU2	ASU3
0	3.16	3.89	4.56	0.96
1	3.19	3.88	4.98	0.88
2	3.23	3.88	5.10	1.06
3	3.23	3.82	5.45	0.99
4	3.40	4.24	5.03	0.92
5	3.19	3.87	4.97	1.01
6	3.15	3.93	4.37	0.95
7	3.37	4.12	4.67	1.22
Average	3.27	4.00	4.90	1.02

SPC-1C LRT™ Average Response Time (ms) Distribution Graph

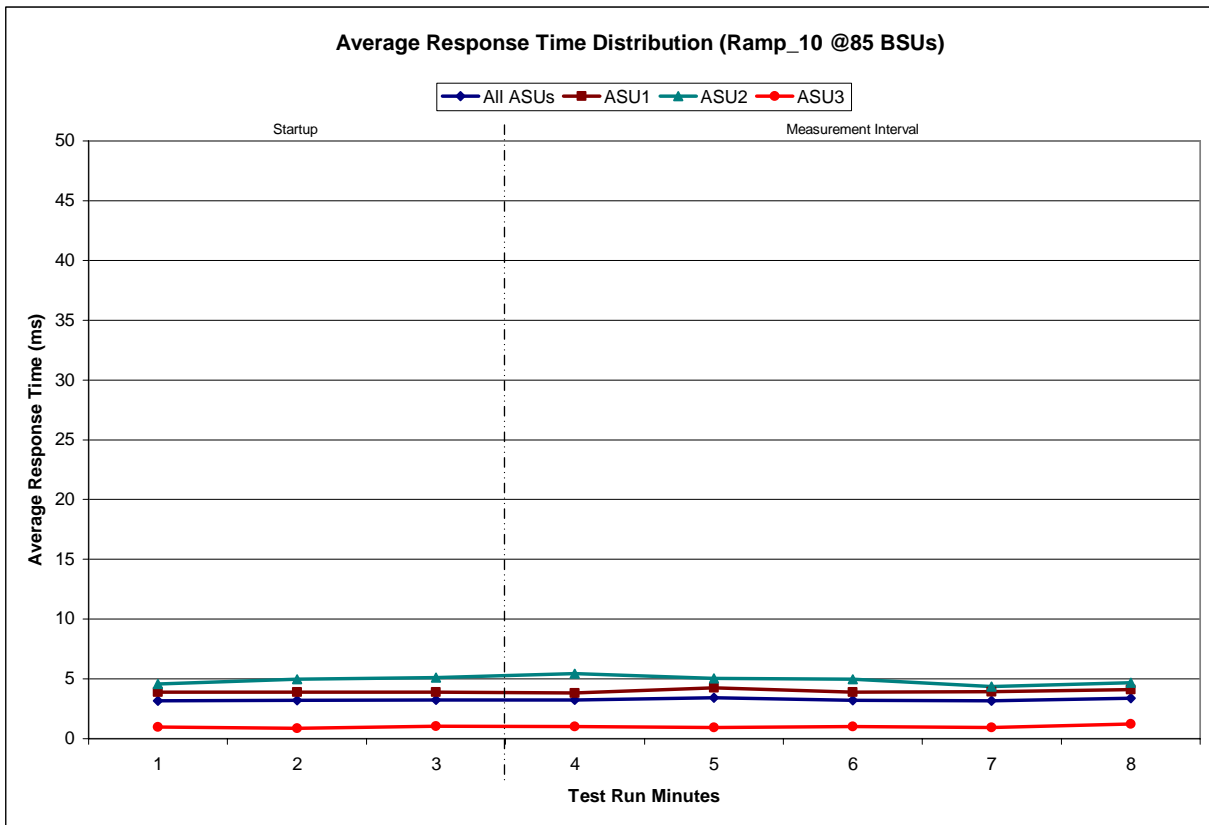

SPC-1C LRT™ (10%) – Measured Intensity Multiplier and Coefficient of Variation

Clause 3.4.3

IM – Intensity Multiplier: The ratio of I/Os for each I/O stream relative to the total I/Os for all I/O streams (ASU1-1 – ASU3-1) as required by the benchmark specification.

Clauses 6.1.0

MIM – Measured Intensity Multiplier: The Measured Intensity Multiplier represents the ratio of measured I/Os for each I/O stream relative to the total I/Os measured for all I/O streams (ASU1-1 – ASU3-1).

Clause 6.3.13.3

COV – Coefficient of Variation: This measure of variation for the Measured Intensity Multiplier cannot exceed 0.5.

	ASU1-1	ASU1-2	ASU1-3	ASU1-4	ASU2-1	ASU2-2	ASU2-3	ASU3-1
IM	0.0350	0.2810	0.0700	0.2100	0.0180	0.0700	0.0350	0.2810
MIM	0.0344	0.2828	0.0704	0.2100	0.0175	0.0699	0.0346	0.2803
COV	0.013	0.005	0.015	0.010	0.025	0.023	0.025	0.007

Repeatability Test

Clause 6.4.4

The Repeatability Test demonstrates the repeatability and reproducibility of the SPC-1C IOPS™ primary metric and SPC-1C LRT™ metric generated in earlier Test Runs.

There are two identical Repeatability Test Phases. Each Test Phase contains two Test Runs. Each of the Test Runs will have a Measurement Interval of no less than five (5) minutes. The two Test Runs in each Test Phase will be executed without interruption or any type of manual intervention.

The first Test Run in each Test Phase is executed at the 10% load point. The Average Response Time from each of the Test Runs is compared to the SPC-1C LRT™ metric. Each Average Response Time value must be less than the SPC-1C LRT™ metric plus 5%.

The second Test Run in each Test Phase is executed at the 100% load point. The I/O Request Throughput from the Test Runs is compared to the SPC-1C IOPS™ primary metric. Each I/O Request Throughput value must be greater than the SPC-1C IOPS™ primary metric minus 5%. In addition, the Average Response Time for each Test Run cannot exceed 30 milliseconds.

If any of the above constraints are not met, the benchmark measurement is invalid.

Clause 10.4.8.4

The FDR shall contain the following for the Repeatability Test:

- 1. A table containing the results of the Repeatability Test.*
- 2. I/O Request Throughput Distribution graph and table for each Repeatability Test Run.*
- 3. An Average Response Time Distribution graph and table for each Repeatability Test Run.*
- 4. The human readable Test Run Results File produced by the Workload Generator. The human readable Test Run Results File produced by the SPC-1C C Workload Generator.*
- 5. A listing of all input parameters supplied to the SPC-1C Workload Generator.*

SPC-1C Workload Generator Input Parameters

The SPC-1C Workload Generator input parameters for the Sustainability, IOPS, Response Time Ramp, Repeatability, and Persistence Test Runs are documented in “Appendix E: SPC-1C Workload Generator Input Parameters” on Page 66.

Repeatability Test Results File

The values for the SPC-1C IOPS™, SPC-1C LRT™, and the Repeatability Test measurements are listed in the tables below.

	SPC-1C IOPS™
<i>Primary Metrics</i>	4,234.44
Repeatability Test Phase 1	4,246.04
Repeatability Test Phase 2	4,240.23

The SPC-1C IOPS™ values in the above table were generated using 100% of the specified Business Scaling Unit (BSU) load level. Each of the Repeatability Test Phase values for SPC-1C IOPS™ must be greater than 95% of the reported SPC-1C IOPS™ Primary Metric.

	SPC-1C LRT™
<i>Primary Metrics</i>	3.27 ms
Repeatability Test Phase 1	3.27 ms
Repeatability Test Phase 2	3.29 ms

The average response time values in the SPC-1C LRT™ column were generated using 10% of the specified Business Scaling Unit (BSU) load level. Each of the Repeatability Test Phase values for SPC-1C LRT™ must be less than 105% of the reported SPC-1C LRT™ Primary Metric.

A link to the test result file generated from each Repeatability Test Run is listed below.

- [Repeatability Test Phase 1, Test Run 1 \(LRT\)](#)
- [Repeatability Test Phase 1, Test Run 2 \(IOPS\)](#)
- [Repeatability Test Phase 2, Test Run 1 \(LRT\)](#)
- [Repeatability Test Phase 2, Test Run 2 \(IOPS\)](#)

Repeatability 1 LRT - I/O Request Throughput Distribution Data

85 BSUs	Start	Stop	Interval	Duration
<i>Start-Up/Ramp-Up</i>	11:39:08	11:42:08	0-2	0:03:00
<i>Measurement Interval</i>	11:42:08	11:47:08	3-7	0:05:00

60 second intervals	All ASUs	ASU1	ASU2	ASU3
0	424.28	252.70	52.88	118.70
1	428.48	254.08	52.27	122.13
2	429.52	255.95	53.58	119.98
3	427.20	254.65	52.88	119.67
4	425.58	254.68	51.53	119.37
5	425.12	252.50	52.27	120.35
6	419.53	248.07	53.58	117.88
7	378.28	222.50	48.47	107.32
Average	415.14	246.48	51.75	116.92

Repeatability 1 LRT - I/O Request Throughput Distribution Graph

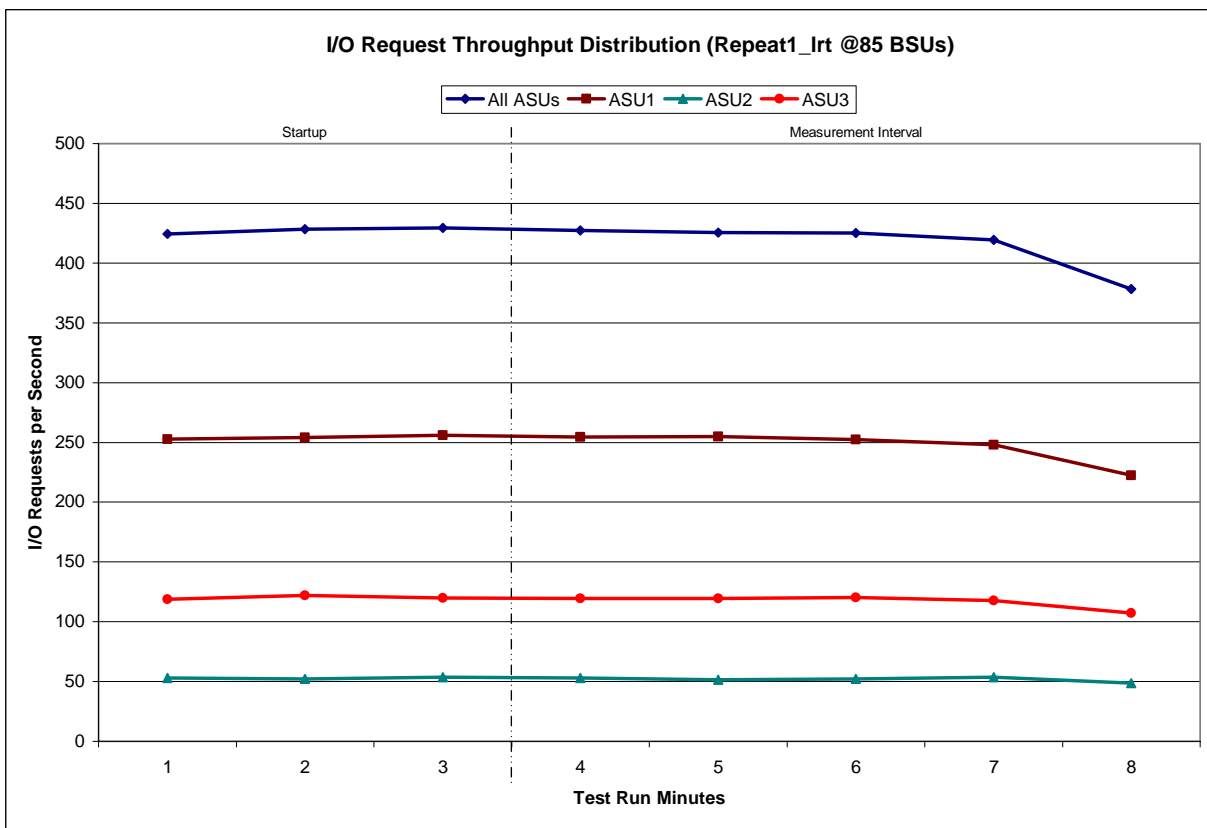

Repeatability 1 LRT –Average Response Time (ms) Distribution Data

85 BSUs	Start	Stop	Interval	Duration
<i>Start-Up/Ramp-Up</i>	11:39:08	11:42:08	0-2	0:03:00
<i>Measurement Interval</i>	11:42:08	11:47:08	3-7	0:05:00
60 second intervals	All ASUs	ASU1	ASU2	ASU3
0	3.21	3.87	4.81	1.07
1	3.26	3.93	5.44	0.94
2	3.31	3.91	5.61	0.99
3	3.25	3.87	5.56	0.93
4	3.19	3.93	4.49	1.03
5	3.13	3.71	4.92	1.12
6	3.35	4.11	4.97	1.03
7	3.44	4.03	5.40	1.31
Average	3.27	3.93	5.07	1.08

Repeatability 1 LRT –Average Response Time (ms) Distribution Graph

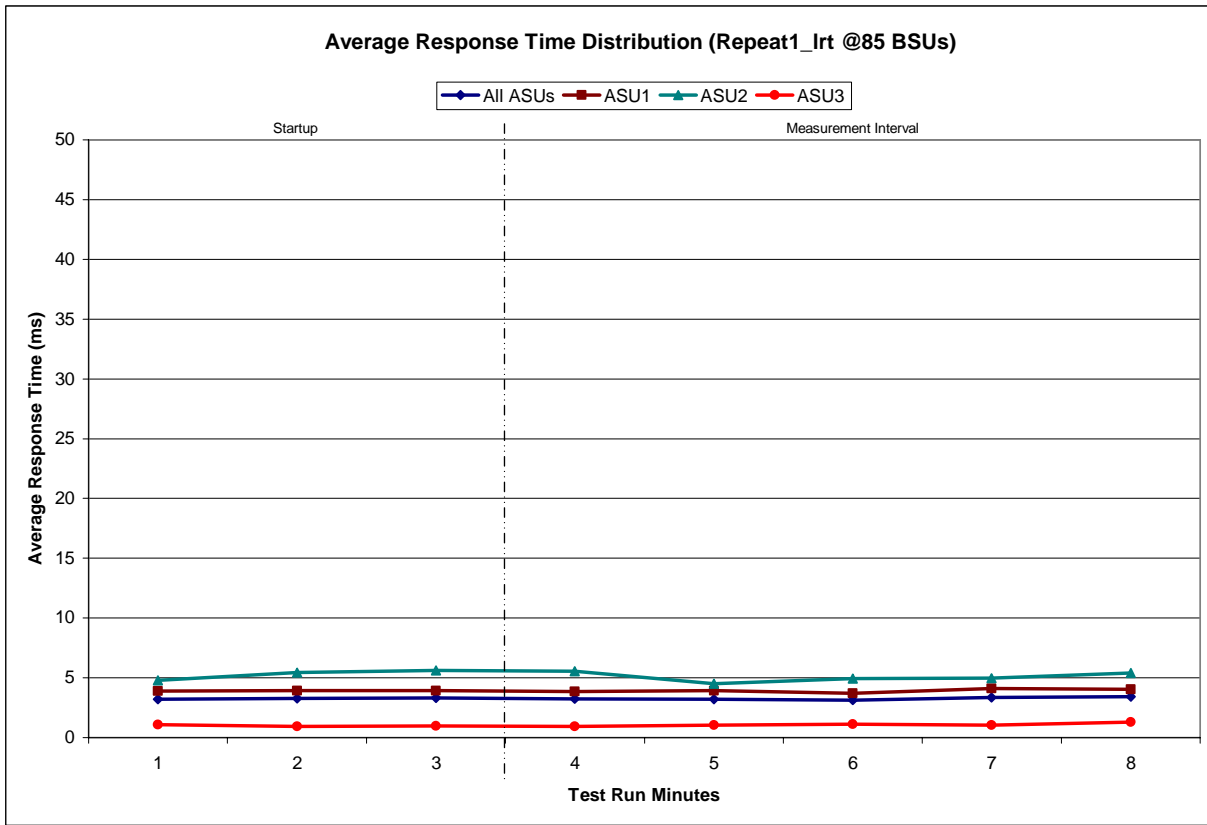

Repeatability 1 IOPS - I/O Request Throughput Distribution Data

850 BSUs	Start	Stop	Interval	Duration
<i>Start-Up/Ramp-Up</i>	11:47:11	11:50:11	0-2	0:03:00
<i>Measurement Interval</i>	11:50:11	11:55:11	3-7	0:05:00
60 second intervals	All ASUs	ASU1	ASU2	ASU3
0	4,256.40	2,534.40	525.27	1,196.73
1	4,238.87	2,525.87	519.57	1,193.43
2	4,233.20	2,523.87	520.03	1,189.30
3	4,247.43	2,527.08	524.87	1,195.48
4	4,253.95	2,532.17	525.55	1,196.23
5	4,243.75	2,532.60	520.00	1,191.15
6	4,267.63	2,539.75	529.03	1,198.85
7	4,217.42	2,514.32	520.48	1,182.62
Average	4,246.04	2,529.18	523.99	1,192.87

Repeatability 1 IOPS - I/O Request Throughput Distribution Graph

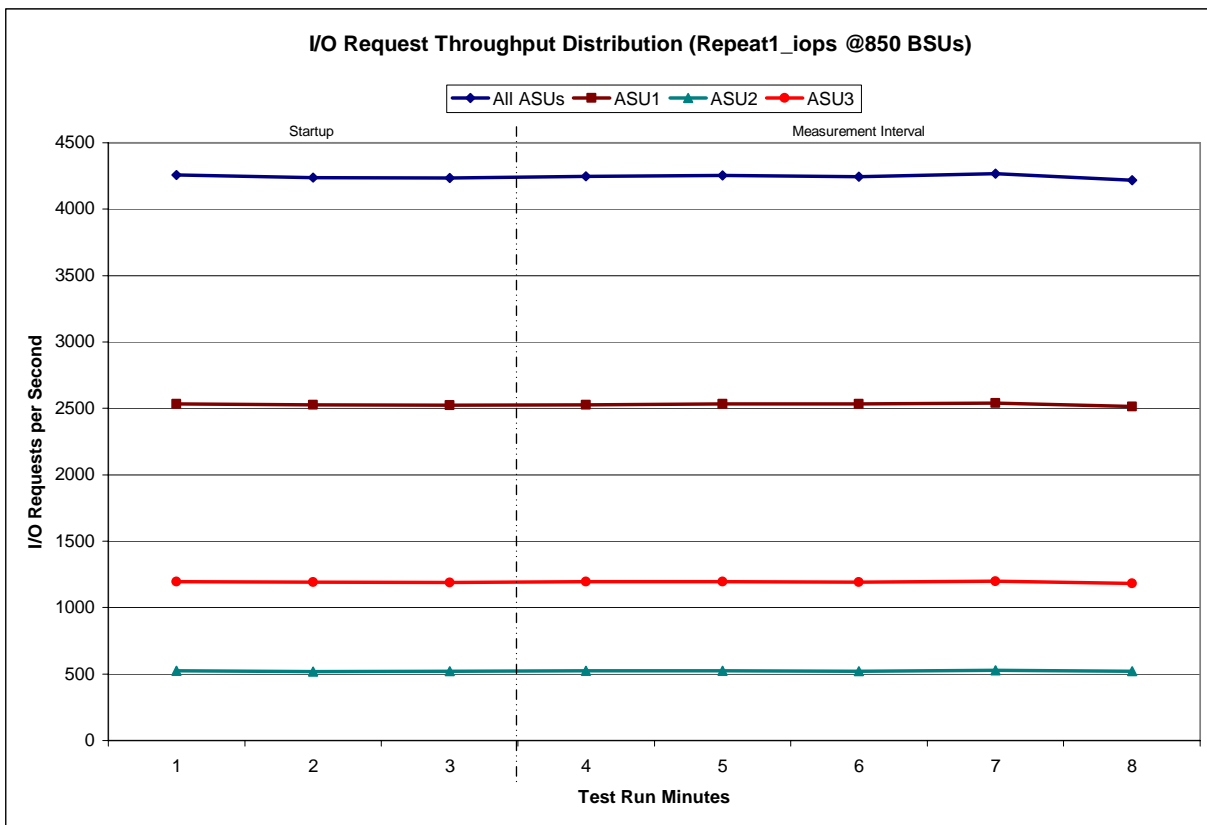

Repeatability 1 IOPS -Average Response Time (ms) Distribution Data

850 BSUs	Start	Stop	Interval	Duration
<i>Start-Up/Ramp-Up</i>	11:47:11	11:50:11	0-2	0:03:00
<i>Measurement Interval</i>	11:50:11	11:55:11	3-7	0:05:00
60 second intervals	All ASUs	ASU1	ASU2	ASU3
0	28.43	31.09	49.63	13.51
1	28.68	31.40	50.12	13.61
2	28.68	31.21	50.26	13.87
3	28.87	31.68	50.26	13.55
4	28.69	31.51	49.57	13.55
5	28.94	31.56	50.94	13.77
6	28.77	31.48	50.79	13.33
7	28.83	31.56	49.92	13.74
Average	28.82	31.56	50.30	13.59

Repeatability 1 IOPS -Average Response Time (ms) Distribution Graph

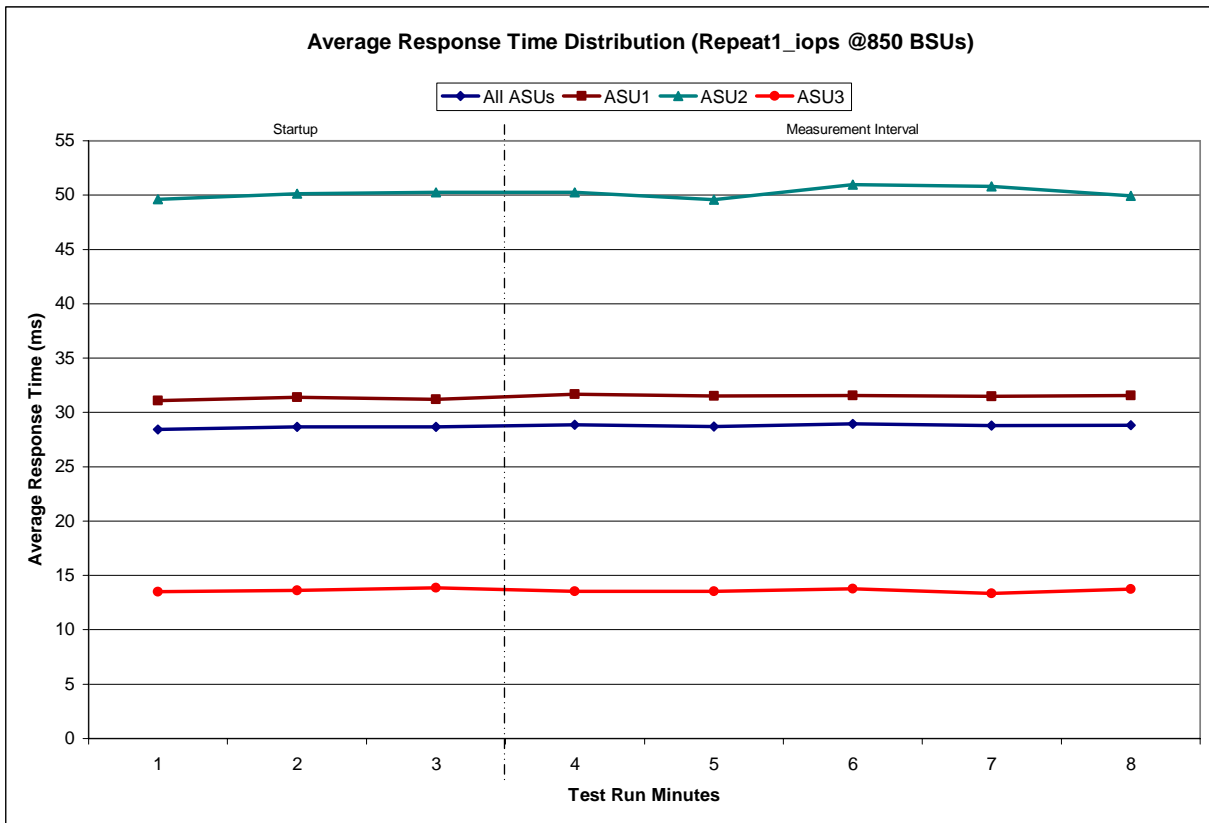

Repeatability 2 LRT - I/O Request Throughput Distribution Data

85 BSUs	Start	Stop	Interval	Duration
<i>Start-Up/Ramp-Up</i>	11:55:14	11:58:14	0-2	0:03:00
<i>Measurement Interval</i>	11:58:14	12:03:14	3-7	0:05:00
60 second intervals	All ASUs	ASU1	ASU2	ASU3
0	427.07	255.90	52.38	118.78
1	422.68	249.92	52.40	120.37
2	426.65	254.08	52.80	119.77
3	430.92	258.75	54.28	117.88
4	423.53	251.40	53.12	119.02
5	430.48	255.12	52.37	123.00
6	423.65	252.70	51.35	119.60
7	377.18	225.42	44.58	107.18
Average	417.15	248.68	51.14	117.34

Repeatability 2 LRT - I/O Request Throughput Distribution Graph

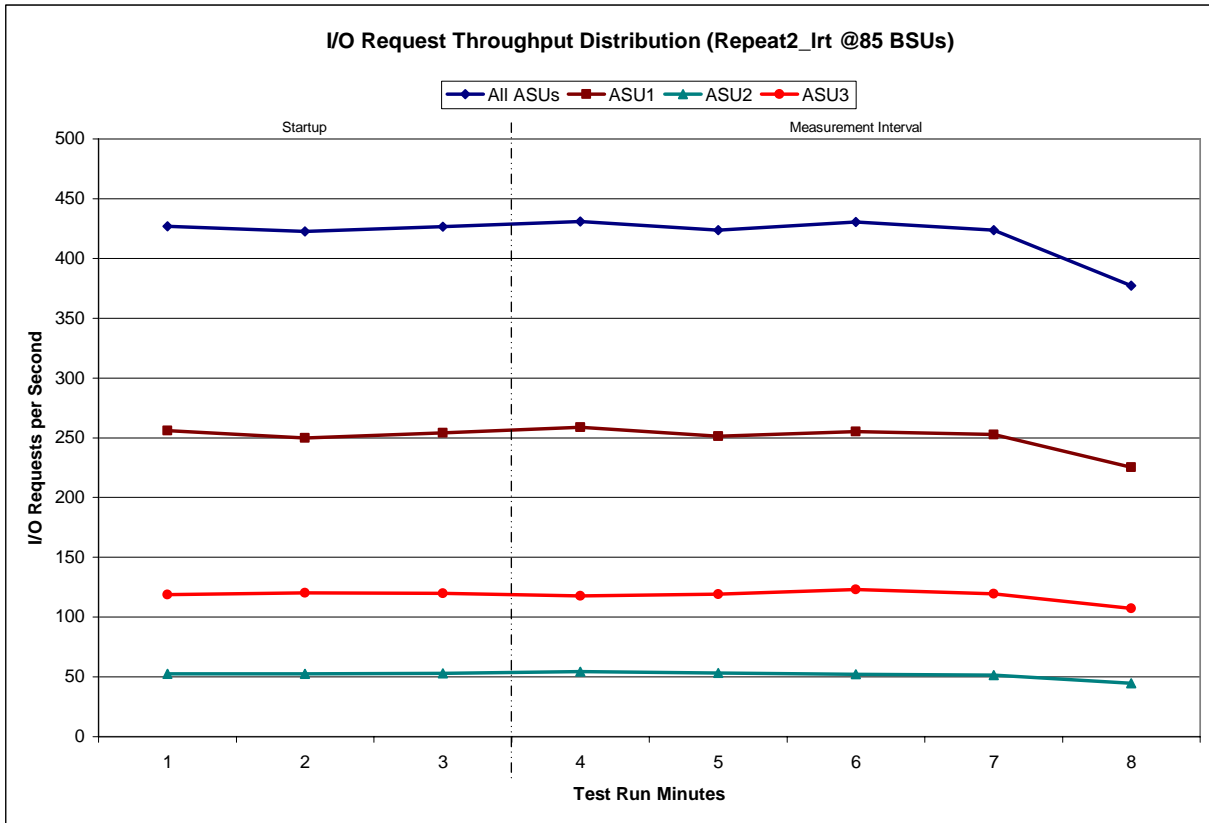

Repeatability 2 LRT –Average Response Time (ms) Distribution Data

85 BSUs	Start	Stop	Interval	Duration
<i>Start-Up/Ramp-Up</i>	11:55:14	11:58:14	0-2	0:03:00
<i>Measurement Interval</i>	11:58:14	12:03:14	3-7	0:05:00
60 second intervals	All ASUs	ASU1	ASU2	ASU3
0	3.16	3.80	4.83	1.03
1	3.22	3.77	5.80	0.95
2	3.12	3.82	4.33	1.10
3	3.23	3.85	5.13	1.01
4	3.19	3.84	4.88	1.07
5	3.73	4.46	5.82	1.32
6	3.22	3.96	4.43	1.15
7	3.06	3.78	4.40	0.98
Average	3.29	3.98	4.93	1.11

Repeatability 2 LRT –Average Response Time (ms) Distribution Graph

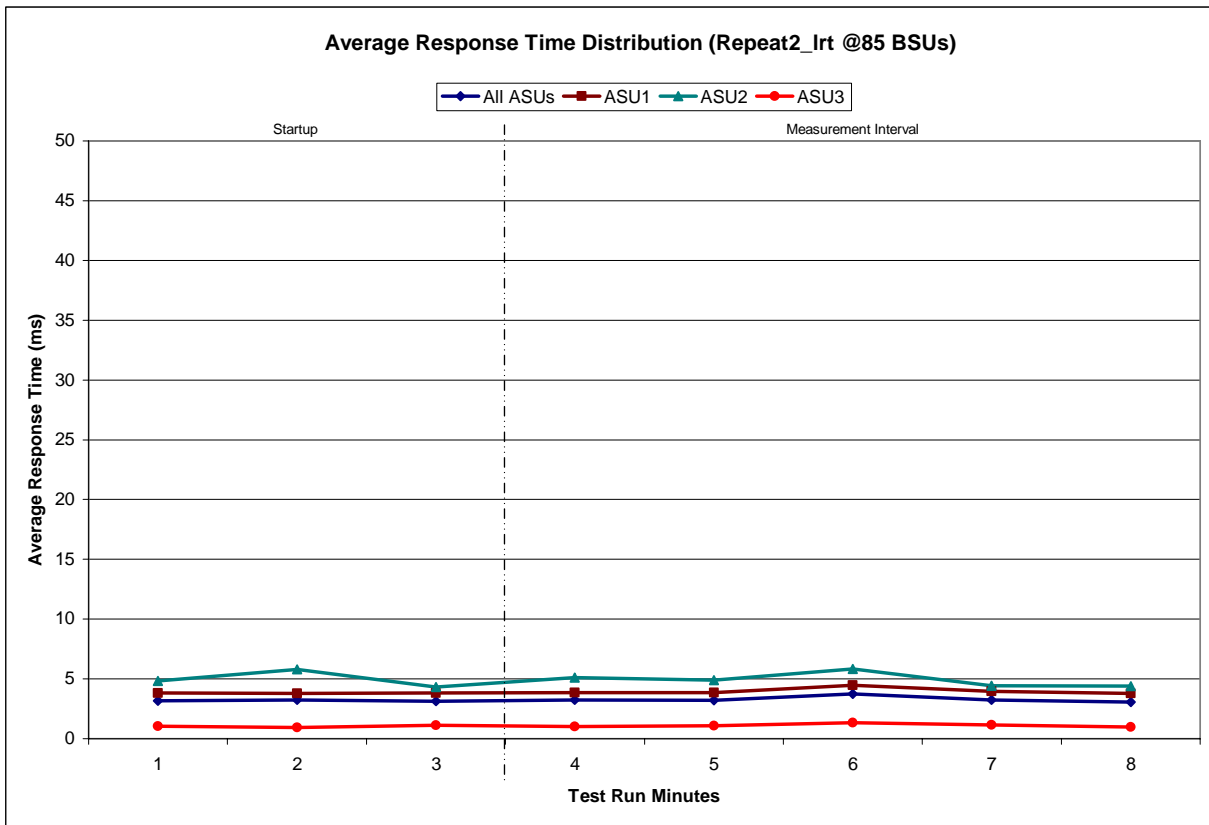

Repeatability 2 IOPS - I/O Request Throughput Distribution Data

850 BSUs	Start	Stop	Interval	Duration
<i>Start-Up/Ramp-Up</i>	12:03:17	12:06:17	0-2	0:03:00
<i>Measurement Interval</i>	12:06:17	12:11:17	3-7	0:05:00
60 second intervals	All ASUs	ASU1	ASU2	ASU3
0	4,244.63	2,528.15	521.55	1,194.93
1	4,252.20	2,536.53	520.40	1,195.27
2	4,255.58	2,537.10	519.23	1,199.25
3	4,250.40	2,534.12	520.52	1,195.77
4	4,259.15	2,537.88	522.90	1,198.37
5	4,253.68	2,532.40	526.62	1,194.67
6	4,237.40	2,529.63	520.12	1,187.65
7	4,200.50	2,506.20	513.25	1,181.05
Average	4,240.23	2,528.05	520.68	1,191.50

Repeatability 2 IOPS - I/O Request Throughput Distribution Graph

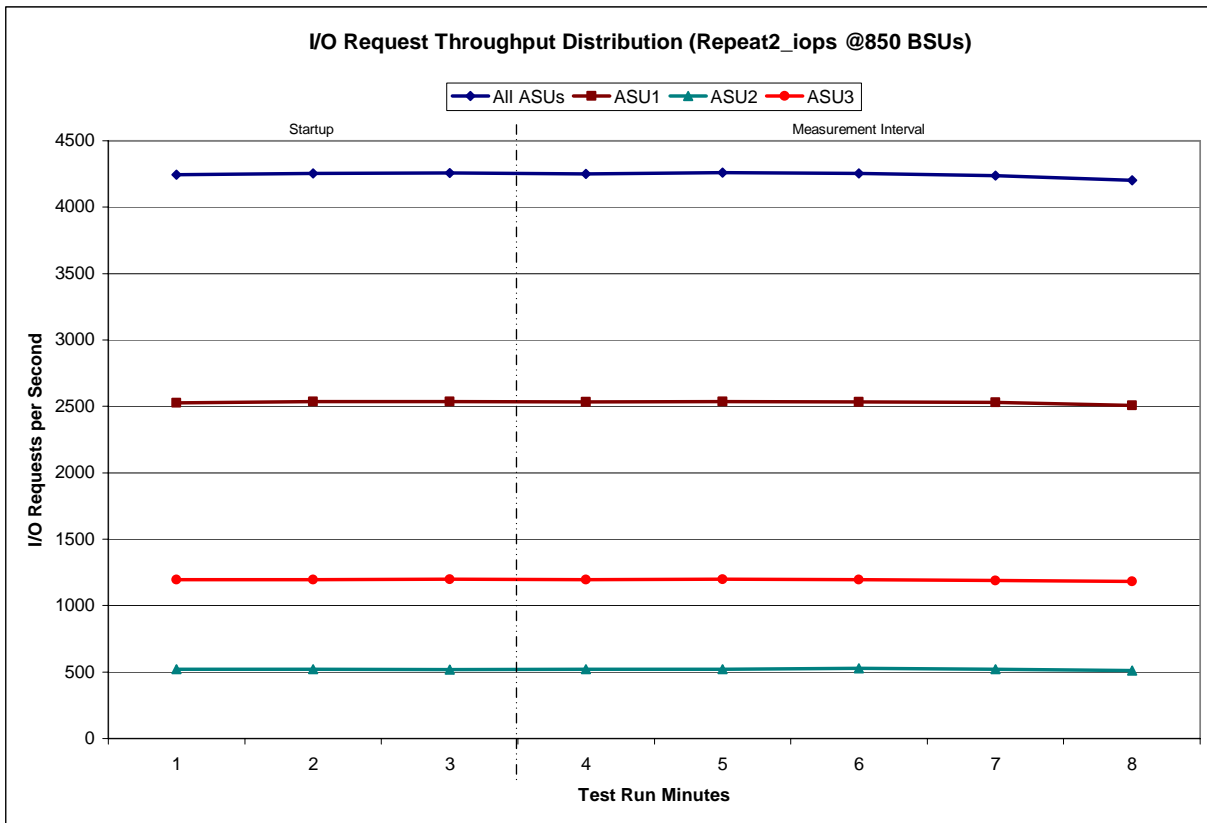

Repeatability 2 IOPS –Average Response Time (ms) Distribution Data

850 BSUs	Start	Stop	Interval	Duration
<i>Start-Up/Ramp-Up</i>	12:03:17	12:06:17	0-2	0:03:00
<i>Measurement Interval</i>	12:06:17	12:11:17	3-7	0:05:00
60 second intervals	All ASUs	ASU1	ASU2	ASU3
0	28.55	31.35	49.62	13.42
1	28.81	31.69	50.21	13.39
2	28.80	31.51	50.80	13.53
3	28.82	31.32	51.17	13.79
4	28.93	31.50	50.98	13.87
5	28.83	31.47	50.95	13.49
6	28.86	31.52	50.68	13.64
7	28.95	31.73	50.27	13.78
Average	28.88	31.51	50.81	13.71

Repeatability 2 IOPS –Average Response Time (ms) Distribution Graph

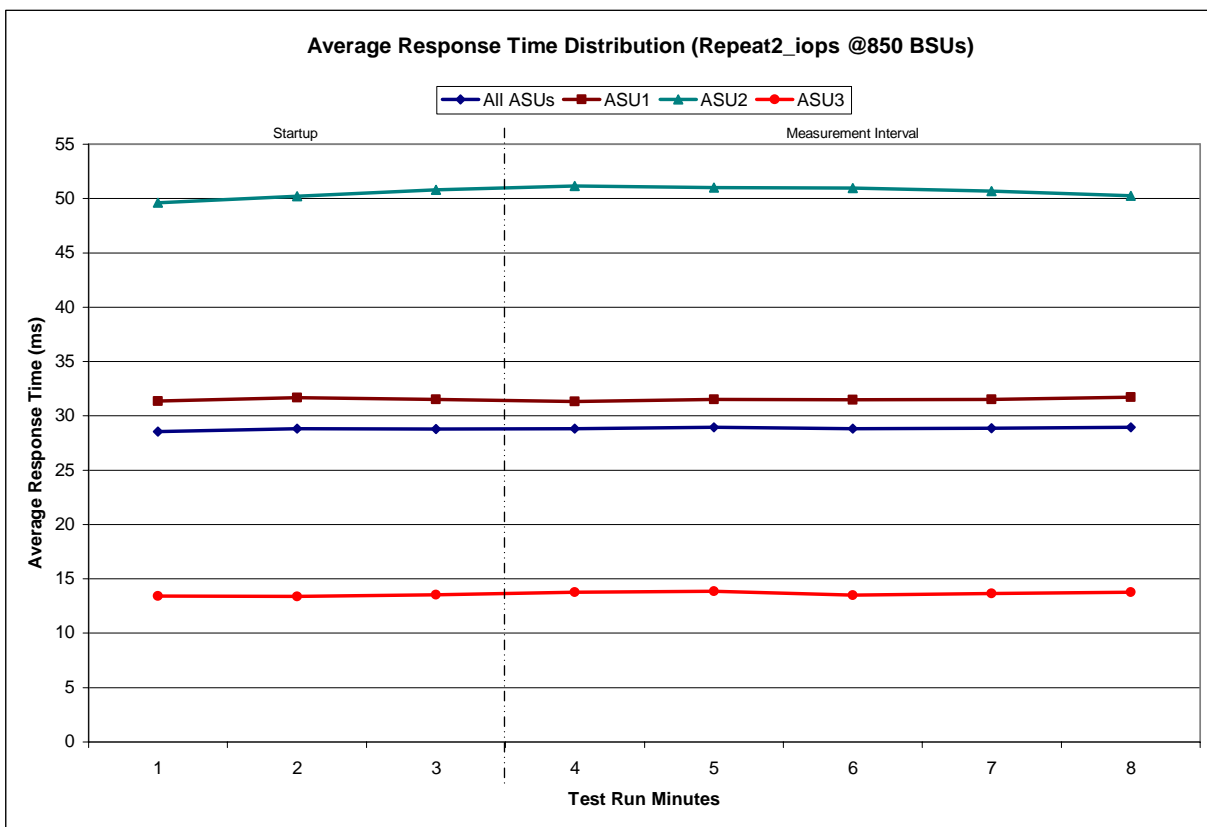

Repeatability 1 (LRT)
Measured Intensity Multiplier and Coefficient of Variation

Clause 3.4.3

IM – Intensity Multiplier: The ratio of I/Os for each I/O stream relative to the total I/Os for all I/O streams (ASU1-1 – ASU3-1) as required by the benchmark specification.

Clauses 6.1.0

MIM – Measured Intensity Multiplier: The Measured Intensity Multiplier represents the ratio of measured I/Os for each I/O stream relative to the total I/Os measured for all I/O streams (ASU1-1 – ASU3-1).

Clause 6.3.13.3

COV – Coefficient of Variation: This measure of variation for the Measured Intensity Multiplier cannot exceed 0.5.

	ASU1-1	ASU1-2	ASU1-3	ASU1-4	ASU2-1	ASU2-2	ASU2-3	ASU3-1
IM	0.0350	0.2810	0.0700	0.2100	0.0180	0.0700	0.0350	0.2810
MIM	0.0355	0.2793	0.0707	0.2082	0.0184	0.0704	0.0359	0.2816
COV	0.036	0.011	0.027	0.009	0.050	0.032	0.036	0.006

Repeatability 1 (IOPS)
Measured Intensity Multiplier and Coefficient of Variation

	ASU1-1	ASU1-2	ASU1-3	ASU1-4	ASU2-1	ASU2-2	ASU2-3	ASU3-1
IM	0.0350	0.2810	0.0700	0.2100	0.0180	0.0700	0.0350	0.2810
MIM	0.0350	0.2811	0.0702	0.2093	0.0181	0.0701	0.0352	0.2809
COV	0.009	0.002	0.010	0.003	0.019	0.007	0.003	0.001

Repeatability 2 (LRT)
Measured Intensity Multiplier and Coefficient of Variation

	ASU1-1	ASU1-2	ASU1-3	ASU1-4	ASU2-1	ASU2-2	ASU2-3	ASU3-1
IM	0.0350	0.2810	0.0700	0.2100	0.0180	0.0700	0.0350	0.2810
MIM	0.0343	0.2829	0.0703	0.2086	0.0188	0.0690	0.0348	0.2813
COV	0.039	0.003	0.018	0.017	0.044	0.025	0.038	0.017

Repeatability 2 (IOPS)
Measured Intensity Multiplier and Coefficient of Variation

	ASU1-1	ASU1-2	ASU1-3	ASU1-4	ASU2-1	ASU2-2	ASU2-3	ASU3-1
<i>IM</i>	<i>0.0350</i>	<i>0.2810</i>	<i>0.0700</i>	<i>0.2100</i>	<i>0.0180</i>	<i>0.0700</i>	<i>0.0350</i>	<i>0.2810</i>
MIM	0.0349	0.2815	0.0697	0.2100	0.0179	0.0700	0.0348	0.2810
COV	0.015	0.003	0.008	0.005	0.023	0.003	0.008	0.002

Data Persistence Test

Clause 7

The Data Persistence Test demonstrates the Tested Storage Configuration (TSC):

- *Is capable of maintain data integrity across a power cycle.*
- *Ensures the transfer of data between Logical Volumes and host systems occurs without corruption or loss.*

The SPC-1C Workload Generator will write 16 block I/O requests at random over the total Addressable Storage Capacity of the TSC for ten (10) minutes at a minimum of 25% of the load used to generate the SPC-1C IOPS™ primary metric. The bit pattern selected to be written to each block as well as the address of the block will be retained in a log file.

The Tested Storage Configuration will be shutdown and restarted using a power off/power on cycle at the end of the above sequence of write operations. In addition, any caches employing battery backup must be flushed/emptied.

The SPC-1C Workload Generator will then use the above log file to verify each block written contains the correct bit pattern.

Clause 10.4.8.5

The FDR shall contain the following for the Data Persistence Test:

1. *A listing of the SPC-1C Workload Generator commands and parameters used to execute each of the Test Runs in the Persistence Test.*
2. *The human readable SPC-1C Test Results File for each of the Test Runs in the Data Persistence Test.*
3. *A table from the successful Persistence Test, which contains the results from the test.*

SPC-1C Workload Generator Input Parameters

The SPC-1C Workload Generator input parameters for the Sustainability, IOPS, Response Time Ramp, Repeatability, and Persistence Test Runs are documented in “Appendix E: SPC-1C Workload Generator Input Parameters” on Page 66.

Data Persistence Test Results File

A link to each test result file generated from each Data Persistence Test is listed below.

[Persistence 1 Test Results File](#)

[Persistence 2 Test Results File](#)

Data Persistence Test Results

Data Persistence Test Results	
Data Persistence Test Run Number: 1	
Total Number of Logical Blocks Written	10,222,800
Total Number of Logical Blocks Verified	8,894,880
Total Number of Logical Blocks that Failed Verification	0
Time Duration for Writing Test Logical Blocks	10 minutes
Size in Bytes of each Logical Block	512
Number of Failed I/O Requests in the process of the Test	0

In some cases the same address was the target of multiple writes, which resulted in more Logical Blocks Written than Logical Blocks Verified. In the case of multiple writes to the same address, the pattern written and verified must be associated with the last write to that address.

PRICED STORAGE CONFIGURATION AVAILABILITY DATE

Clause 10.4.9

The committed delivery date for general availability (Availability Date) of all products that comprise the Priced Storage Configuration must be reported. When the Priced Storage Configuration includes products or components with different availability dates, the reported Availability Date must be the date at which all components are committed to be available. All availability dates, whether for individual components or for the Priced Storage Configuration as a whole, must be disclosed to a precision of one day.

The Availability Date shall be stated in the FDR by either a combination of specific alphanumeric month, numeric day, and numeric year or as "Currently Available" in the case where all components that comprise the Priced Storage Configuration are currently available for customer order and shipment.

The LSI MegaRAID SAS 8888ELP as documented in this Full Disclosure Report is currently available for customer purchase and shipment.

ANOMALIES OR IRREGULARITIES

Clause 10.4.10

The FDR shall include a clear and complete description of any anomalies or irregularities encountered in the course of executing the SPC-1C benchmark that may in any way call into question the accuracy, verifiability, or authenticity of information published in the FDR.

There were no anomalies or irregularities encountered during the SPC-1C Onsite Audit of the LSI MegaRAID SAS 8888ELP.

APPENDIX A: SPC-1C GLOSSARY

“Decimal” (*powers of ten*) Measurement Units

In the storage industry, the terms “kilo”, “mega”, “giga”, “tera”, “peta”, and “exa” are commonly used prefixes for computing performance and capacity. For the purposes of the SPC workload definitions, all of the following terms are defined in “powers of ten” measurement units.

- A kilobyte (KB) is equal to 1,000 (10^3) bytes.
- A megabyte (MB) is equal to 1,000,000 (10^6) bytes.
- A gigabyte (GB) is equal to 1,000,000,000 (10^9) bytes.
- A terabyte (TB) is equal to 1,000,000,000,000 (10^{12}) bytes.
- A petabyte (PB) is equal to 1,000,000,000,000,000 (10^{15}) bytes
- An exabyte (EB) is equal to 1,000,000,000,000,000,000 (10^{18}) bytes

“Binary” (*powers of two*) Measurement Units

The sizes reported by many operating system components use “powers of two” measurement units rather than “power of ten” units. The following standardized definitions and terms are also valid and may be used in this document.

- A kibibyte (KiB) is equal to 1,024 (2^{10}) bytes.
- A mebibyte (MiB) is equal to 1,048,576 (2^{20}) bytes.
- A gibibyte (GiB) is equal to 1,073,741,824 (2^{30}) bytes.
- A tebibyte (TiB) is equal to 1,099,511,627,776 (2^{40}) bytes.
- A pebibyte (PiB) is equal to 1,125,899,906,842,624 (2^{50}) bytes.
- An exbibyte (EiB) is equal to 1,152,921,504,606,846,967 (2^{60}) bytes.

SPC-1C Data Repository Definitions

Total ASU Capacity: The total storage capacity read and written in the course of executing the SPC-1C benchmark.

Application Storage Unit (ASU): The logical interface between the storage and SPC-1C Workload Generator. The three ASUs (Data, User, and Log) are typically implemented on one or more Logical Volume.

Logical Volume: The division of Addressable Storage Capacity into individually addressable logical units of storage used in the SPC-1C benchmark. Each Logical Volume is implemented as a single, contiguous address space.

Addressable Storage Capacity: The total storage (sum of Logical Volumes) that can be read and written by application programs such as the SPC-1C Workload Generator.

Configured Storage Capacity: This capacity includes the Addressable Storage Capacity and any other storage (parity disks, hot spares, etc.) necessary to implement the Addressable Storage Capacity.

Physical Storage Capacity: The formatted capacity of all storage devices physically present in the Tested Storage Configuration (TSC).

Data Protection Overhead: The storage capacity required to implement the selected level of data protection.

Required Storage: The amount of Configured Storage Capacity required to implement the Addressable Storage Configuration, excluding the storage required for the three ASUs.

Global Storage Overhead: The amount of Physical Storage Capacity that is required for storage subsystem use and unavailable for use by application programs.

Total Unused Storage: The amount of storage capacity available for use by application programs but not included in the Total ASU Capacity.

SPC-1C Data Protection Levels

Protected: Data protection in the event of a single point of failure of any of the configured storage devices.

Unprotected: The Test Sponsor asserts no claim of data protection in the event of a single point of failure.

SPC-1C Test Execution Definitions

Average Response Time: The sum of the Response Times for all Measured I/O Requests divided by the total number of Measured I/O Requests.

Completed I/O Request: An I/O Request with a Start Time and a Completion Time (see "I/O Completion Types" below).

Completion Time: The time recorded by the Workload Generator when an I/O Request is satisfied by the TSC as signaled by System Software.

Data Rate: The data transferred in all Measured I/O Requests in an SPC-1C Test Run divided by the length of the Test Run in seconds.

Expected I/O Count: For any given I/O Stream and Test Phase, the product of 50 times the BSU level, the duration of the Test Phase in seconds, and the Intensity Multiplier for that I/O Stream.

Failed I/O Request: Any I/O Request issued by the Workload Generator that could not be completed or was signaled as failed by System Software. A Failed I/O Request has no Completion Time (see "I/O Completion Types" below).

I/O Request Throughput: The total number of Measured I/O requests in an SPC-1C Test Run divided by the duration of the Measurement Interval in seconds.

In-Flight I/O Request: An I/O Request issued by the I/O Command Generator to the TSC that has a recorded Start Time, but does not complete within the Measurement Interval (see “I/O Completion Types” below).

Measured I/O Request: A Completed I/O Request with a Completion Time occurring within the Measurement Interval (see “I/O Completion Types” below).

Measured Intensity Multiplier: The percentage of all Measured I/O Requests that were issued by a given I/O Stream.

Measurement Interval: The finite and contiguous time period, after the TSC has reached Steady State, when data is collected by a Test Sponsor to generate an SPC-1C test result or support an SPC-1C test result.

Ramp-Up: The time required for the Benchmark Configuration (BC) to produce Steady State throughput after the Workload Generator begins submitting I/O Requests to the TSC for execution.

Ramp-Down: The time required for the BC to complete all I/O Requests issued by the Workload Generator. The Ramp-Down period begins when the Workload Generator ceases to issue new I/O Requests to the TSC.

Response Time: The Response Time of a Measured I/O Request is its Completion Time minus its Start Time.

Start Time: The time recorded by the Workload Generator when an I/O Request is submitted, by the Workload Generator, to the System Software for execution on the Tested Storage Configuration (TSC).

Start-Up: The period that begins after the Workload Generator starts to submit I/O requests to the TSC and ends at the beginning of the Measurement Interval.

Shut-Down: The period between the end of the Measurement Interval and the time when all I/O Requests issued by the Workload Generator have completed or failed.

Steady State: The consistent and sustainable throughput of the TSC. During this period the load presented to the TSC by the Workload Generator is constant.

Test: A collection of Test Phases and or Test Runs sharing a common objective.

Test Run: The execution of SPC-1C for the purpose of producing or supporting an SPC-1C test result. SPC-1C Test Runs may have a finite and measured Ramp-Up period, Start-Up period, Shut-Down period, and Ramp-Down period as illustrated in the “SPC-1C Test Run Components” below. All SPC-1C Test Runs shall have a Steady State period and a Measurement Interval.

Test Phase: A collection of one or more SPC-1C Test Runs sharing a common objective and intended to be run in a specific sequence.

I/O Completion Types

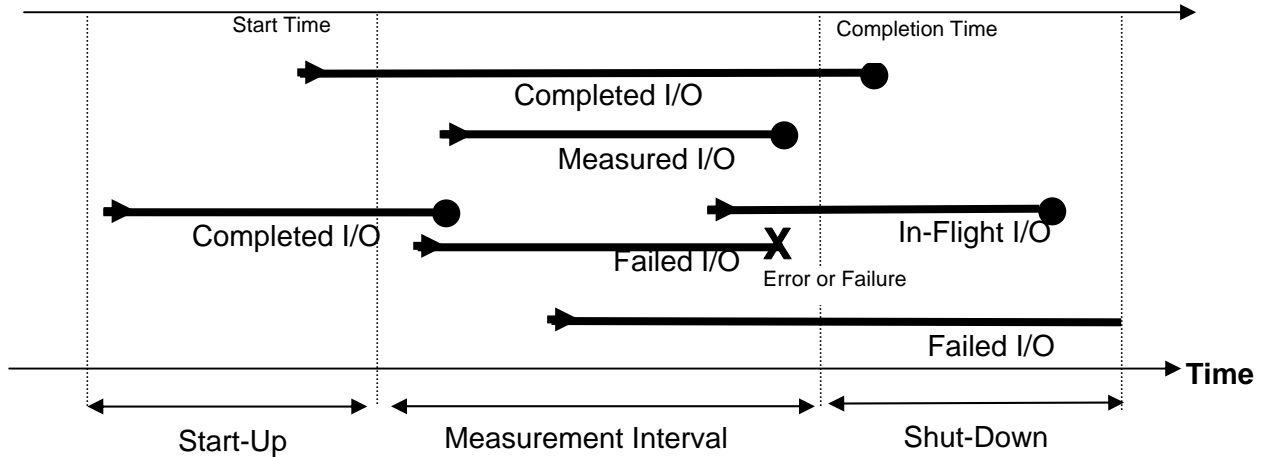

SPC-1C Test Run Components

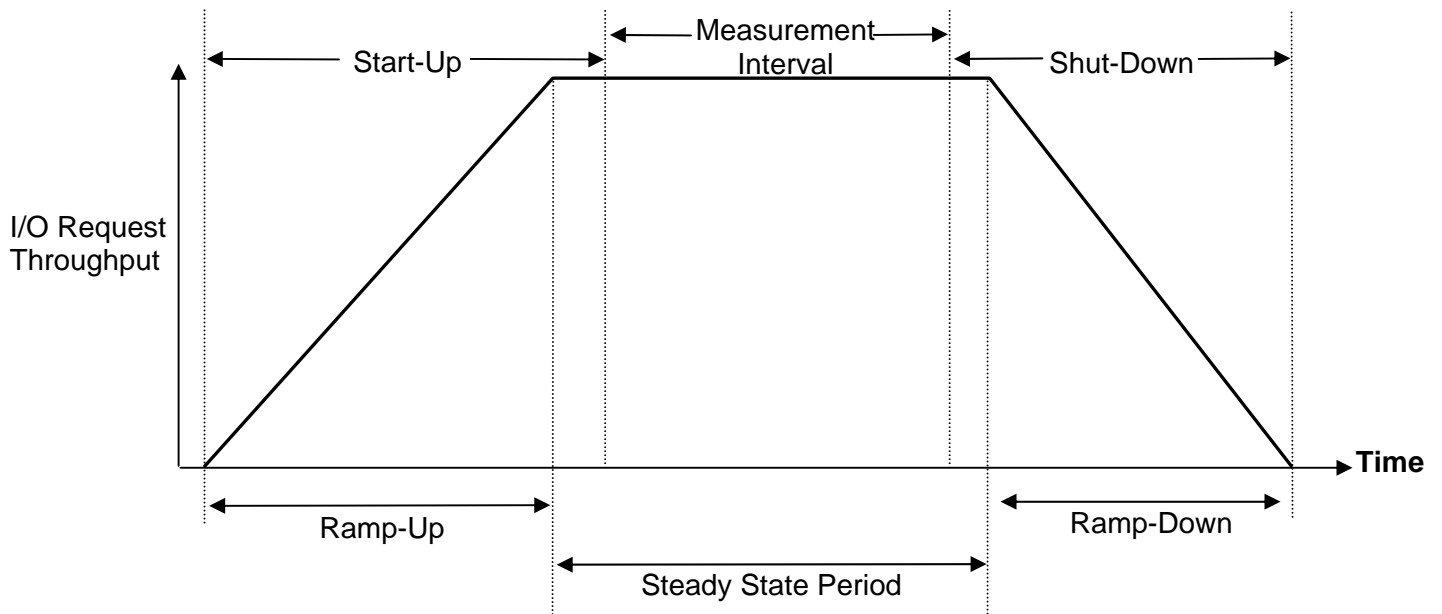

APPENDIX B: CUSTOMER TUNABLE PARAMETERS AND OPTIONS

Raid-5 Volume Parameters/Options

The following LSI MegaCLI commands were used to change default values for the LSI MegaRAID SAS 8888ELP using the script listed below. This script is executed after successful completion of the steps documented in *Appendix C: Tested Storage Configuration (TSC) Creation*.

```
REM ***** Change Defaults *****
set adptr=0
Set BBU=CachedBadBBU
set access=RW
set DiskCache=-EnDskCache

MegaCLI -LDSetProp %BBU% -Lall -a%adptr%
MegaCLI -LDSetProp -%access% -Lall -a%adptr%
MegaCLI -LDSetProp %DiskCache% -Lall -a%adptr%
MegaCLI -LDSetProp -name one -L0 -a%adptr%
MegaCLI -LDSetProp -name two -L1 -a%adptr%
MegaCLI -LDSetProp -name three -L2 -a%adptr%
MegaCLI -LDSetProp -name four -L3 -a%adptr%
MegaCLI -LDSetProp -name five -L4 -a%adptr%
MegaCLI -LDSetProp -name six -L5 -a%adptr%
MegaCLI -LDSetProp -name seven -L6 -a%adptr%
MegaCLI -LDSetProp -name eight -L7 -a%adptr%
REM *****
```

Disk Enclosure Backplane Configuration

The default configuration for the AIX Xtore disk enclosure is that all twenty-four disks are attached to a single x4 SAS link. For maximum throughput, that default was changed to zone the enclosure into two banks of twelve disks each. After zoning, the first twelve slots, 0 – 11 will be connected to the Primary side of the enclosure, and the remaining twelve slots, 12 – 23 will be connected to the Secondary side of the enclosure.

To change the default configuration of the enclosure, perform the following steps. It is not necessary for the enclosure to be populated for this procedure, but it does have to be powered on.

- Attach to the COM port on the rear of Primary expander of the 24-drive disk enclosure
- Attach other end of the serial cable to the serial port on a computer on which a terminal emulator program is running
- In the terminal emulator window, enter the following commands to configure the Primary side of the enclosure:
 - tZoneCfg -s 0-7 1
 - tZoneCfg -s 8-13 1
 - tZoneCfg -s 20-23 1
 - tZoneCfg -w
 - tZoneCfg -d
- Attach to the COM port on the rear of Secondary expander of the 24-drive disk enclosure. In the terminal emulator window, enter the following commands to configure the Secondary side of the enclosure:

- ***tZoneCfg -s 0-13 2***
- ***tZoneCfg -s 14-23 2***
- ***tZoneCfg -w***
- ***tZoneCfg -d***
- Power cycle the enclosure for zoning to take effect.
- Once the enclosure is zoned, settings are stored in non-volatile memory, so will persist through power cycles.

APPENDIX C: TESTED STORAGE CONFIGURATION (TSC) CREATION

Create RAID-5 Volumes

The MegaCLI utility can be used to create, delete, and manage RAID volumes through a command line interface. The utility is available on the LSI website at:

http://www.lsi.com/storage_home/products_home/internal RAID/megaraid_sas/megaraid_sas_8888elp/index.html

The following commands, embedded in script files, were used to create the RAID-5 volumes.

Clear RAID volumes

First, clear any RAID volumes that may be on the controller card.

```
REM *****Clear All RAID Volumes *****
MegaCLI -cfgclr -aALL
REM *****
```

Get disk list

Second, get a list all attached disks. Record the enclosure and slot numbers.

```
REM ***** Get Physical Disk Enclosure & Slot *****
MegaCLI -PDInfo -aALL
REM *****
```

Create the RAID-5 Volumes

Third, use the enclosure and slot numbers to modify the script below. Typically, the enclosure number is the same for all disks. "48" is used in this configuration. Typically the Slot numbers are adjacent integers.

```
REM ***** Create 8 RAID 5 Volumes *****
REM Span : NO
REM # HDD in Vol : 3
REM Phys HDD List : 0,1,2 etc
REM Spares : NO
REM Encryption : NO
REM RAID Level : 5
REM Stripe Size : 64 KB
REM LD Name : one,two,three,four,five
REM LD Read Policy : Adaptive Read Ahead
REM LD Write Policy : Write Back, Bad BBU
REM LD IO Policy : Direct IO
REM Access Policy : Read / Write
REM Disk Cache Policy : Enable
REM Initialization : Quick Init
REM *****

set adptr=0
set DriveList0=[48:0, 48:1, 48:2]
set DriveList1=[48:3, 48:4, 48:5]
set DriveList2=[48:6, 48:7, 48:8]
set DriveList3=[48:9, 48:10, 48:11]
set DriveList4=[48:12, 48:13, 48:14]
set DriveList5=[48:15, 48:16, 48:17]
set DriveList6=[48:18, 48:19, 48:20]
set DriveList7=[48:21, 48:22, 48:23]
set level=5
set stripe=64
set ReadCache=ADRA
set WriteCache=WB
```

```
Set BBU=CachedBadBBU
set IOpolicy=Direct
set access=RW
set DiskCache=-EnDskCache
set BI=-Dsbl

@echo on

REM ***** Create all Volumes *****
MegaCli -CfgLdAdd -r%level%DriveList0% %WriteCache% %ReadCache%
%IOpolicy% %BBU% -sz%stripe% -a%adptr%
MegaCli -CfgLdAdd -r%level%DriveList1% %WriteCache% %ReadCache%
%IOpolicy% %BBU% -sz%stripe% -a%adptr%
MegaCli -CfgLdAdd -r%level%DriveList2% %WriteCache% %ReadCache%
%IOpolicy% %BBU% -sz%stripe% -a%adptr%
MegaCli -CfgLdAdd -r%level%DriveList3% %WriteCache% %ReadCache%
%IOpolicy% %BBU% -sz%stripe% -a%adptr%
MegaCli -CfgLdAdd -r%level%DriveList4% %WriteCache% %ReadCache%
%IOpolicy% %BBU% -sz%stripe% -a%adptr%
MegaCli -CfgLdAdd -r%level%DriveList5% %WriteCache% %ReadCache%
%IOpolicy% %BBU% -sz%stripe% -a%adptr%
MegaCli -CfgLdAdd -r%level%DriveList6% %WriteCache% %ReadCache%
%IOpolicy% %BBU% -sz%stripe% -a%adptr%
MegaCli -CfgLdAdd -r%level%DriveList7% %WriteCache% %ReadCache%
%IOpolicy% %BBU% -sz%stripe% -a%adptr%
```

Configure ASU-1, ASU-2, and ASU-3 from the RAID-5 Volumes

Create three logical volumes, using a portion of each RAID5 volume. The Windows Configuration Manager, as documented below, was used to create the three logical volumes.

Create an alignment partition

- Start the Windows Computer Manager and select **Disk Management**
- Right click and select **Convert to Dynamic Disk** for volumes 1 through 5
- Right click on Disk 1 and select **New Volume**
- In the New Volume Wizard, select **Next**
- Select Volume to create: **Striped**, then **Next**
- Select **Disk 2**, then **Add 7** times to include all 8 disks in the stripe volume
- In the text box **Select the amount of space in MB**, enter **8** then **Next**
- Assign Drive Letter **M** then **Next**
- Select **Do not format this volume**, then **Next**
- Select **Finish**

Configure ASU-3

- Right click on Disk 1 and select **New Volume**
- In the New Volume Wizard, select **Next**
- Select Volume to create: **Striped**, then **Next**
- Select **Disk 2**, then **Add 7** times to include all 8 disks in the stripe volume

- In the text box **Select the amount of space in MB**, enter **3500** then **Next**
- Assign Drive Letter **Z** then **Next**
- Select **Do not format this volume**, then **Next**
- Select **Finish**

Configure ASU-2

- Right click on Disk 1 and select **New Volume**
- In the New Volume Wizard, select **Next**
- Select Volume to create: **Striped**, then **Next**
- Select **Disk 2**, then **Add 7** times to include all 8 disks in the stripe volume
- In the text box **Select the amount of space in MB**, enter **15751** then **Next**
- Assign Drive Letter **Y** then **Next**
- Select **Do not format this volume**, then **Next**
- Select **Finish**

Configure ASU-1

- Right click on Disk 1 and select **New Volume**
- In the New Volume Wizard, select **Next**
- Select Volume to create: **Striped**, then **Next**
- Select **Disk 2**, then **Add 7** times to include all 8 disks in the stripe volume
- In the text box **Select the amount of space in MB**, enter **15751** then **Next**
- Assign Drive Letter **X** then **Next**
- Select **Do not format this volume**, then **Next**
- Select **Finish**

Remove alignment partition

- Left click to select partition **M**
- Right click and select **Delete Volume**, then **Yes**.

Disable Volume Initialization

The controller will begin initialization upon the first I/O to each volume. Since the initial data stored on the new volumes is of no consequence for the benchmark measurements, volume initialization can be bypassed. The following MegaCLI commands will abort and disable initialization of all RAID volumes:

```
MegaCLI -LDBI -abort -Lall -aALL  
MegaCLI -LDBI -dsbl -Lall -aALL
```

The commands may be executed from the command line of a DOS window and only need to be executed once during the initial configuration process.

APPENDIX D: SPC-1C WORKLOAD GENERATOR STORAGE COMMANDS AND PARAMETERS

The content of SPC-1C Workload Generator command and parameter files, used in this benchmark, is listed below.

metrics.txt

```
* ASU Logical Volume Definitions

sd=asu1_1,lun=\\.x:
sd=asu2_1,lun=\\.y:
sd=asu3_1,lun=\\.z:

* Metrics Test

rd=sustain,bsus=850,startup=180,elapsed=3600,interval=60
rd=ramp_100,bsus=850,startup=180,elapsed=300,interval=60
rd=ramp_95,bsus=808,startup=180,elapsed=300,interval=60
rd=ramp_90,bsus=765,startup=180,elapsed=300,interval=60
rd=ramp_80,bsus=680,startup=180,elapsed=300,interval=60
rd=ramp_50,bsus=425,startup=180,elapsed=300,interval=60
rd=ramp_10,bsus=85,startup=180,elapsed=300,interval=60
```

repeat1.txt

```
* ASU Logical Volume Definitions

sd=asu1_1,lun=\\.x:
sd=asu2_1,lun=\\.y:
sd=asu3_1,lun=\\.z:

* Repeatability Test Phase 1

rd=repeat1_lrt,bsus=85,startup=180,elapsed=300,interval=60
rd=repeat1_iops,bsus=850,startup=180,elapsed=300,interval=60
```

repeat2.txt

```
* ASU Logical Volume Definitions

sd=asu1_1,lun=\\.x:
sd=asu2_1,lun=\\.y:
sd=asu3_1,lun=\\.z:

* Repeatability Test Phase 2

rd=repeat2_lrt,bsus=85,startup=180,elapsed=300,interval=60
rd=repeat2_iops,bsus=850,startup=180,elapsed=300,interval=60
```

persist1.txt

* ASU Logical Volume Definitions

sd=asu1_1,lun=\\.x:

sd=asu2_1,lun=\\.y:

sd=asu3_1,lun=\\.z:

* Persistence Test Run 1

rd=pers_1,bsus=213

persist2.txt

* ASU Logical Volume Definitions

sd=asu1_1,lun=\\.x:

sd=asu2_1,lun=\\.y:

sd=asu3_1,lun=\\.z:

* Persistence Test Run 1

rd=pers_2

APPENDIX E: SPC-1C WORKLOAD GENERATOR INPUT PARAMETERS

Primary Metrics Test, Repeatability Test, and Persistence Test Run 1

The following script was used to execute the Primary Metrics Test (*Sustainability Test Phase, IOPS Test Phase, and Response Time Ramp Test Phase*), Repeatability Test (*Repeatability Test Phase 1 and Repeatability Test Phase 2*), and Persistence Test Run 1 in an uninterrupted sequence.

```
java spc1 -fmetrics.txt -ometrics SPCOut -br 5
java spc1 -frepeat1.txt -orepeatability1 SPCOut -br 5
java spc1 -frepeat2.txt -orepeatability2 SPCOut -br 5
java spc1 -fpersist1.txt -opersistence1 SPCOut -br 5
```

Cache Flush

The RAID cache is battery backed-up and must be flushed following Persistence Test Run 1 and prior to the power cycle that precedes Persistence Test Run 2. The following command was executed to flush the RAID cache at that point.

```
MegaCLI -AdpCacheFlush -aall
```

Persistence Test Run 2

The following script was used to execute Persistence Test Run 2.

```
java spc1 -fpersist2.txt -opersistence2 SPCOut -br 5
```

APPENDIX F: THIRD-PARTY QUOTES

LSI MegaRAID SAS 8888ELP

LSI
LSI LSI00142 x8 lane PCI Express 1.0a compliant PCI Power Management Specification 1.1 compliant SATA / SAS MegaRAID SAS 8888ELP Kit RAID levels 0, 1, 5, and 6 RAID spans 10, 50 and 60 - Retail SAS 8-E 8-1 PT RAID 0/1/5/6/10/50 PCI-E

\$789.99
3 Business Day Shipping \$8.25 (Not available in HI, AK and PR)
In Stock

Image Viewer

Protect Your Investment
Avoid the headaches of out-of warranty repairs; get the ultimate protection for your purchase! (expand for options)

Special Offers

- No Payments for up to 12 Months, minimum purchase required, subject to credit approval. [NPA important disclosures](#)
- No Payments for 90 Days On purchases over \$250 with Bill Me Later®! [BML important disclosures](#)

Similar Items
Not the product you're looking for? We can make some suggestions to help you decide on a product that fits your needs. [view similar products](#)

CUSTOMER REVIEWS		SPECIFICATIONS	
Model			
Brand	LSI		
Model	LSI00142		
Specifications			
Type	SATA / SAS		
External Ports	Two SAS SFF8088 x4 external connectors		
Internal Connectors	Two SAS SFF8087 x4 internal connectors		
Interface	x8 lane PCI Express 1.0a compliant PCI Power Management Specification 1.1 compliant		
Transfer Rate	Up to 3Gb/s per port		
RAID	RAID levels 0, 1, 5, and 6 RAID spans 10, 50 and 60		
Dimensions	7.7" x 2.5"		
Features			
Features	Auto-resume on array rebuild Auto resume array reconstruction Online Capacity Expansion (OCE) RAID Level Migration (RLM) Create 64 logical volumes Up to 64TB LUN support Comprehensive management tools LED fault indicator header Audible alarm circuit		
Packaging			
Package Contents	LSI00142 Quick Installation Guide Resource Disk SAS Cable Low-profile Bracket		

Seagate Savvio™ 15K, 36 GB SAS Disk Drives

The screenshot shows a web page for Global Micro. At the top, there are navigation links: Home, Customer Service, About Us, and Contact Us. On the right, there is a shopping cart icon with '0 Items In Cart', a 'View Cart' link, and a 'My Account' link. The main header features the Global Micro logo and several brand logos: Dell, Maxtor, Seagate, HP, and Fujitsu. A search bar is present with the text 'Enter Keyword or Part Number' and a 'GO' button. Below the header is a navigation menu with categories: Controller Cards, CPU, Electronics, Mass Storage, Memory, Misc., Networking, Printers & Acces., RAID Solutions, Servers, and Video Cards. The main content area displays a product listing for a '36GB 15K HD SAS SFF 2.5LP 11IN HPL DP [ST9367515S] - NEW'. The price is listed as '\$276.00' and the status is 'In Stock'. There is a 'Click to enlarge' link and two buttons: 'REVIEWS' and 'ADD TO CART'. On the left, there is a 'Manufacturers' dropdown menu with 'Please Select' as the current selection. At the bottom of the page, there is a footer with copyright information: 'Copyright © 2008. All rights reserved.' and 'Powered by osCommerce and BWS'. There are also links for 'Privacy Notice', 'Terms Of Service', and 'Shipping & Returns', and logos for Visa and MasterCard.

AIC XJ SA26-224R Disk Enclosure



LSI Logic Corporation
Sales Quote# 4227527
Created By: Jackie Fuentes

Bill To: LSI Logic Corporation
 Attn: Accounts Payable
 MS LSI A/P
 4420 Arrowswest Dr.
 Colorado Springs, CO 80907

Ship To: LSI Logic Corporation
 Attn: Bob Frizzell
 47658 Kato Road
 FREMONT, CA 94538

Ship-Via		Member Reference		Project	Cost Center
UPS Ground					
PO Number	Date	Sales Person		Terms	Num
frizzell1117a	2008-11-17	Jerry Morin - 708-799-0582 - TeamJerry@moredirect.com		Net 30	4227527

Quote Items

Qty	Mfg Part #	Description	Manufacturer	Unit Price	Extended
1	XJ-SA26-224R-B	SAS JBOD 2U 24-BAY 2.5DRIVE D UAL EXP BLK(XJ-SA26-224R-B)	AIC	\$2,087.14	\$2,087.14
Total (Product Only):					\$2,087.14

* Pricing and availability are subject to change.
*** Prices do not include tax or shipping**

Signature _____ Date _____
 Print Name _____

MoreDirect, Inc.
 4800 T-Rex Ave., Suite 300
 Boca Raton, Florida 33431
 Tel. (561) 237-3300.

External SAS Cables



SEARCH OUR INVENTORY:

7 character minimum

Home
New Products
Custom Requests
EX4-10Gb Ethernet Cables
Emulation
Fiber Optic Cables
Fibre Channel
Infiniband Cables
Mini-SAS (iPass)
Optical Transceivers
PCIe (PCI Express) Cables
SAS Products
SATA Products
SEST Cables
Special Adapters
USB

CONTACT INFO ABOUT US VIEW CART CHECKOUT
Email Password [Forgot password?](#)

Mini-SAS Cables

[Mini-SAS \(iPass\)](#) » [Mini-SAS Cables](#)

SA-8888-1m

Part #:	SA-8888-1m
Description:	MiniSAS (SFF-8088) - MiniSAS (SFF-8088), 1 meter
Minimum Quantity:	1
List Price:	\$48.00
Wiring Diagrams:	WB

For Corporate or Volume Pricing, call 303-810-5110

Mini SAS (**ISAS**) is the newest generation of Serial Attached SCSI (SAS) cables. The smaller connector design and positive locking save space and insure reliable connections. This line of cables is ready for the jump to 6Gb/s planned for 2007.

SERIAL CABLES is pleased to announce our new **Mini SAS** series of Cables to meet the requirements of the new Mini SAS specifications from the SCSI T-10 committee. The two primary connectors in **Mini SAS** are the 26-CKT External connector and the 35-CKT Internal connector that can also carry Sideband signals if they are used.

In the Marketplace for SAS and SATA products, there has been considerable confusion in the use of the terms "straight-through" and "crossover" cables. To alleviate this confusion **Serial Cables** uses part numbers and descriptions that more clearly indicate the use of each cable.

Our Part numbering is simple to understand. The last two numbers of the specified connector type (Example: SFF-8088, this cable connector would be represented as an 88 in the part number). Also, the first two number indicate the "Host Side" and the second two number indicate the "Target Side" and lastly the length in meters. Simply mouse over any specified part number/description in the table below and get a visual of the cable connector ends for the part number you are selecting.

