



**SPC BENCHMARK 1™**  
**FULL DISCLOSURE REPORT**

**NETWORK APPLIANCE, INC.** *(TEST SPONSOR)*  
**EMC CLARION CX3 MODEL 40**  
*(SNAPVIEW™ ENABLED)*

**SPC-1 V1.10.1**

**Submitted for Review: January 29, 2008**

**Submission Identifier: A00060**

**Revised: January 31, 2008**

**First Edition – January 2008**

THE INFORMATION CONTAINED IN THIS DOCUMENT IS DISTRIBUTED ON AN AS IS BASIS WITHOUT ANY WARRANTY EITHER EXPRESS OR IMPLIED. The use of this information or the implementation of any of these techniques is the customer's responsibility and depends on the customer's ability to evaluate and integrate them into the customer's operational environment. While each item has been reviewed by Network Appliance, Inc. for accuracy in a specific situation, there is no guarantee that the same or similar results will be obtained elsewhere. Customers attempting to adapt these techniques to their own environment do so at their own risk.

This publication was produced in the United States. Network Appliance, Inc. does not offer all of the products, services, or features discussed in this document and the information is subject to change with notice. Consult your local Network Appliance, Inc. representative for information on products and services available in your area.

© Copyright Network Appliance, Inc. 2008. All rights reserved.

Permission is hereby granted to reproduce this document in whole or in part, provided the copyright notice as printed above is set forth in full text on the title page of each item reproduced.

**Trademarks**

SPC Benchmark-1, SPC-1, SPC-1 IOPS, and SPC-1 LRT are trademarks of the Storage Performance Council. NetApp is registered trademarks of Network Appliance, Inc. in the United States and other countries. All other brands, trademarks, and product names are the property of their respective owners.

## Table of Contents

<b>Audit Certification</b> .....	<b>vii</b>
<b>Audit Certification (cont.)</b> .....	<b>viii</b>
<b>Letter of Good Faith</b> .....	<b>ix</b>
<b>Executive Summary</b> .....	<b>10</b>
<b>Test Sponsor and Contact Information</b> .....	<b>10</b>
<b>Revision Information and Key Dates</b> .....	<b>10</b>
<b>Tested Storage Product (TSP) Description</b> .....	<b>10</b>
<b>Summary of Results</b> .....	<b>11</b>
<b>Storage Capacities and Relationships</b> .....	<b>11</b>
<b>Response Time - Throughput Curve</b> .....	<b>12</b>
<b>Response Time - Throughput Data</b> .....	<b>12</b>
<b>Tested Storage Configuration Pricing (Priced Storage Configuration)</b> .....	<b>13</b>
<b>Differences between the Tested Storage Configuration (TSC) and Priced Storage Configuration</b> .....	<b>13</b>
<b>Benchmark Configuration/Tested Storage Configuration Diagram</b> .....	<b>14</b>
<b>Benchmark Configuration/Tested Storage Configuration Components</b> .....	<b>15</b>
<b>Configuration Information</b> .....	<b>16</b>
<b>Benchmark Configuration (BC)/Tested Storage Configuration (TSC) Diagram</b> .....	<b>16</b>
<b>Storage Network Configuration</b> .....	<b>16</b>
<b>Host System Configuration</b> .....	<b>16</b>
<b>Customer Tunable Parameters and Options</b> .....	<b>17</b>
<b>Tested Storage Configuration (TSC) Description</b> .....	<b>17</b>
<b>SPC-1 Workload Generator Storage Configuration</b> .....	<b>17</b>
<b>SPC-1 Data Repository</b> .....	<b>18</b>
<b>Storage Capacities and Relationships</b> .....	<b>18</b>
SPC-1 Storage Capacities .....	<b>18</b>
SPC-1 Storage Hierarchy Ratios .....	<b>18</b>
SPC-1 Storage Capacities and Relationships Illustration .....	<b>19</b>
<b>Logical Volume Capacity and ASU Mapping</b> .....	<b>19</b>
<b>SPC-1 Benchmark Execution Results</b> .....	<b>20</b>
<b>SPC-1 Tests, Test Phases, and Test Runs</b> .....	<b>20</b>
<b>Primary Metrics Test - Sustainability Test Phase</b> .....	<b>21</b>
SPC-1 Workload Generator Input Parameters .....	<b>21</b>
Sustainability Test Results File .....	<b>21</b>
Sustainability - Data Rate Distribution Data (MB/second).....	<b>22</b>

Sustainability – Data Rate Distribution Graph .....	23
Sustainability – I/O Request Throughput Distribution Data .....	24
Sustainability – I/O Request Throughput Distribution Graph .....	25
Sustainability – Average Response Time (ms) Distribution Data .....	26
Sustainability – Average Response Time (ms) Distribution Graph .....	27
Sustainability – Response Time Frequency Distribution Data .....	28
Sustainability – Response Time Frequency Distribution Graph .....	28
Sustainability – Measured Intensity Multiplier and Coefficient of Variation.....	29
<b>Primary Metrics Test – IOPS Test Phase .....</b>	<b>30</b>
SPC-1 Workload Generator Input Parameters .....	30
IOPS Test Results File.....	30
IOPS Test Run – I/O Request Throughput Distribution Data .....	31
IOPS Test Run – I/O Request Throughput Distribution Graph.....	31
IOPS Test Run – Average Response Time (ms) Distribution Data .....	32
IOPS Test Run – Average Response Time (ms) Distribution Graph .....	32
IOPS Test Run – Response Time Frequency Distribution Data .....	33
IOPS Test Run –Response Time Frequency Distribution Graph.....	33
IOPS Test Run – I/O Request Information.....	34
IOPS Test Run – Measured Intensity Multiplier and Coefficient of Variation.....	34
<b>Primary Metrics Test – Response Time Ramp Test Phase .....</b>	<b>35</b>
SPC-1 Workload Generator Input Parameters .....	35
Response Time Ramp Test Results File.....	35
Response Time Ramp Distribution (IOPS) Data.....	36
Response Time Ramp Distribution (IOPS) Graph .....	37
SPC-1 LRT™ Average Response Time (ms) Distribution Data.....	38
SPC-1 LRT™ Average Response Time (ms) Distribution Graph .....	38
SPC-1 LRT™ (10%) – Measured Intensity Multiplier and Coefficient of Variation .....	39
<b>Repeatability Test .....</b>	<b>40</b>
SPC-1 Workload Generator Input Parameters .....	40
Repeatability Test Results File .....	41
Repeatability 1 LRT – I/O Request Throughput Distribution Data.....	42
Repeatability 1 LRT – I/O Request Throughput Distribution Graph .....	42
Repeatability 1 LRT –Average Response Time (ms) Distribution Data .....	43
Repeatability 1 LRT –Average Response Time (ms) Distribution Graph.....	43
Repeatability 1 IOPS – I/O Request Throughput Distribution Data .....	44
Repeatability 1 IOPS – I/O Request Throughput Distribution Graph.....	44
Repeatability 1 IOPS –Average Response Time (ms) Distribution Data.....	45
Repeatability 1 IOPS –Average Response Time (ms) Distribution Graph .....	45
Repeatability 2 LRT – I/O Request Throughput Distribution Data.....	46

Repeatability 2 LRT – I/O Request Throughput Distribution Graph .....	46
Repeatability 2 LRT –Average Response Time (ms) Distribution Data .....	47
Repeatability 2 LRT –Average Response Time (ms) Distribution Graph.....	47
Repeatability 2 IOPS – I/O Request Throughput Distribution Data .....	48
Repeatability 2 IOPS – I/O Request Throughput Distribution Graph.....	48
Repeatability 2 IOPS –Average Response Time (ms) Distribution Data.....	49
Repeatability 2 IOPS –Average Response Time (ms) Distribution Graph .....	49
Repeatability 1 (LRT) Measured Intensity Multiplier and Coefficient of Variation .....	50
Repeatability 1 (IOPS) Measured Intensity Multiplier and Coefficient of Variation .....	50
Repeatability 2 (LRT) Measured Intensity Multiplier and Coefficient of Variation .....	50
Repeatability 2 (IOPS) Measured Intensity Multiplier and Coefficient of Variation .....	51
<b>Data Persistence Test.....</b>	<b>52</b>
SPC-1 Workload Generator Input Parameters .....	52
Data Persistence Test Results File .....	52
Data Persistence Test Results.....	53
<b>Priced Storage Configuration Availability Date.....</b>	<b>54</b>
<b>Pricing Information.....</b>	<b>54</b>
<b>Anomalies or Irregularities .....</b>	<b>54</b>
<b>Appendix A: SPC-1 Glossary .....</b>	<b>55</b>
“Decimal” ( <i>powers of ten</i> ) Measurement Units.....	55
“Binary” ( <i>powers of two</i> ) Measurement Units.....	55
SPC-1 Data Repository Definitions.....	55
SPC-1 Data Protection Levels .....	56
SPC-1 Test Execution Definitions .....	56
I/O Completion Types .....	58
SPC-1 Test Run Components .....	58
<b>Appendix B: Customer Tunable Parameters and Options.....</b>	<b>59</b>
Windows 2003 Server.....	59
CX3-40 Storage System.....	59
<b>Appendix C: Tested Storage Configuration (TSC) Creation .....</b>	<b>60</b>
<b>Storage System.....</b>	<b>60</b>
Create RAID Groups.....	60
Create LUNs.....	60
<b>Host System .....</b>	<b>63</b>
<b>Brocade FCP Switches.....</b>	<b>65</b>
<b>Appendix D: SPC-1 Workload Generator Storage Commands and Parameters .....</b>	<b>66</b>

**Appendix E: SPC-1 Workload Generator Input Parameters ..... 67**  
    **Primary Metrics Test, Repeatability Test, and Persistence Test Run 1 .....67**  
    **Persistence Test Run 2.....67**  
**Appendix F: Third-Party Quote ..... 68**  
**Appendix G: Use of EMC’s SnapView™ ..... 69**

## AUDIT CERTIFICATION



Steve Daniel  
Network Appliance, Inc.  
7301 Kit Creek Road, Building 1  
Research Triangle Park, NC 27709

January 29, 2008

The SPC Benchmark 1™ results listed below for the EMC CLARiiON CX3 Model 40 (*SnapView™ enabled*) were produced in compliance with the SPC Benchmark 1™ V1.10.1 Onsite Audit requirements.

SPC Benchmark 1™ V1.10.1 Results	
Tested Storage Configuration (TSC) Name: EMC CLARiiON CX3 Model 40 ( <i>SnapView™ enabled</i> )	
Metric	Reported Result
SPC-1 IOPS™	8,997.17
SPC-1 Price-Performance	\$59.49/SPC-1 IOPS™
Total ASU Capacity	7,054.148 GB
Data Protection Level	Mirroring
Total TSC Price (including three-year maintenance)	\$535,251

The following SPC Benchmark 1™ Onsite Audit requirements were reviewed and found compliant with V1.10.1 of the SPC Benchmark 1™ specification:

- A Letter of Good Faith, signed by a senior executive.
- The following Data Repository storage items were verified by physical inspection and information supplied by Network Appliance, Inc.:
  - ✓ Physical Storage Capacity and requirements.
  - ✓ Configured Storage Capacity and requirements.
  - ✓ Addressable Storage Capacity and requirements.
  - ✓ Capacity of each Logical Volume and requirements.
  - ✓ Capacity of each Application Storage Unit (ASU) and requirements.
- An appropriate diagram of the Benchmark Configuration (BC)/Tested Storage Configuration (TSC).
- Physical verification of the components to match the above diagram.

Storage Performance Council  
643 Bair Island Road, Suite 103  
Redwood City, CA 94062  
[AuditService@storageperformance.org](mailto:AuditService@storageperformance.org)  
650.556.9384



**LETTER OF GOOD FAITH**

7 January, 2008

Walter Baker  
Gradient Systems  
643 Blair Island Road, Suite 103  
Redwood City, CA 94063-2755

To: Walter Baker  
Subject: SPC-1 Letter of Good Faith for the EMC CLARiiON CX 3 Model 40

Network Appliance, Inc is the SPC-1 Test Sponsor for the above listed product. To the best of our knowledge and belief, the required SPC-1 benchmark results and materials we have submitted for that product are complete, accurate, and in full compliance with V1.10.1 of the SPC-1 benchmark specification.

In addition, we have reported any items in the Benchmark Configuration and execution of the benchmark that affected the reported results even if the items are not explicitly required to be disclosed by the SPC-1 benchmark specification.

Sincerely,

A handwritten signature in black ink, appearing to read 'Phil Brotherton'.

Phil Brotherton  
Vice President  
Enterprise Applications Business Unit

Network Appliance, Inc. 495 East Java Drive Sunnyvale, CA 94088 Telephone 408.822.6000 Fax 408.822.4501  
www.netapp.com

## **EXECUTIVE SUMMARY**

### **Test Sponsor and Contact Information**

<b>Test Sponsor and Contact Information</b>	
<b>Test Sponsor Primary Contact</b>	Network Appliance, Inc. – <a href="http://www.netapp.com/">http://www.netapp.com/</a> Steve Daniel – <a href="mailto:daniel@netapp.com">daniel@netapp.com</a> 7301 Kit Creek Road Building 1 Research Triangle Park, NC 27709 Phone: (919) 476-5726 FAX: (919) 476-4272
<b>Test Sponsor Alternate Contact</b>	Network Appliance, Inc. – <a href="http://www.netapp.com/">http://www.netapp.com/</a> Dean Brock – <a href="mailto:Dean.Brock@netapp.com">Dean.Brock@netapp.com</a> 7301 Kit Creek Road Building 1 Research Triangle Park, NC 27709 Phone: (919) 476-5609 FAX: (919) 476-4272
<b>Auditor</b>	Storage Performance Council – <a href="http://www.storageperformance.org">http://www.storageperformance.org</a> Walter E. Baker – <a href="mailto:AuditService@StoragePerformance.org">AuditService@StoragePerformance.org</a> 643 Bair Island Road, Suite 103 Redwood City, CA 94063 Phone: (650) 556-9384 FAX: (650) 556-9385

### **Revision Information and Key Dates**

<b>Revision Information and Key Dates</b>	
<b>SPC-1 Specification revision number</b>	V1.10.1
<b>SPC-1 Workload Generator revision number</b>	V2.00.04a
<b>Date Results were first used publicly</b>	January 29, 2008
<b>Date the FDR was submitted to the SPC</b>	January 29, 2008
<b>Date revised FDR was submitted to the SPC</b> Inclusion of omitted capacities diagram: page 11 Activation of hyperlinks to results files: various pages	January 31, 2008
<b>Date the TSC is available for shipment to customers</b>	currently available
<b>Date the TSC completed audit certification</b>	January 29, 2008

### **Tested Storage Product (TSP) Description**

The CX3-40 is the performance workhorse of EMC's CLARiiON CX3 UltraScale series. Featuring quad Xeon processors, 8 GB memory, quad 4 Gb/s back-end loops, and support for up to 240 drives, the CX3-40 appeals to commercial and enterprise customers with OLTP and messaging (e.g., Microsoft Exchange) workloads, and with larger requirements for array-based replication. Enterprise-class business continuance features include hot-pluggable redundant hardware, hot spare disk drives, multi-path failover, snapshots, cloning, local/remote mirroring, and non-disruptive firmware upgrades.

### Summary of Results

SPC-1 Results	
Tested Storage Configuration (TSC) Name: EMC CLARiiON CX3 Model 40	
Metric	Reported Result
SPC-1 IOPS™	8,997.17
SPC-1 Price-Performance	\$59.49/SPC-1 IOPS™
Total ASU Capacity	7,054.148GB
Data Protection Level	Mirroring
Total TSC Price (including three-year maintenance)	\$535,251

**SPC-1 IOPS™** represents the maximum I/O Request Throughput at the 100% load point.

**Total ASU (Application Storage Unit) Capacity** represents the total storage capacity read and written in the course of executing the SPC-1 benchmark.

A **Data Protection Level** of Mirroring configures two or more identical copies of user data.

### Storage Capacities and Relationships

The following diagram documents the various storage capacities, used in this benchmark, and their relationships.

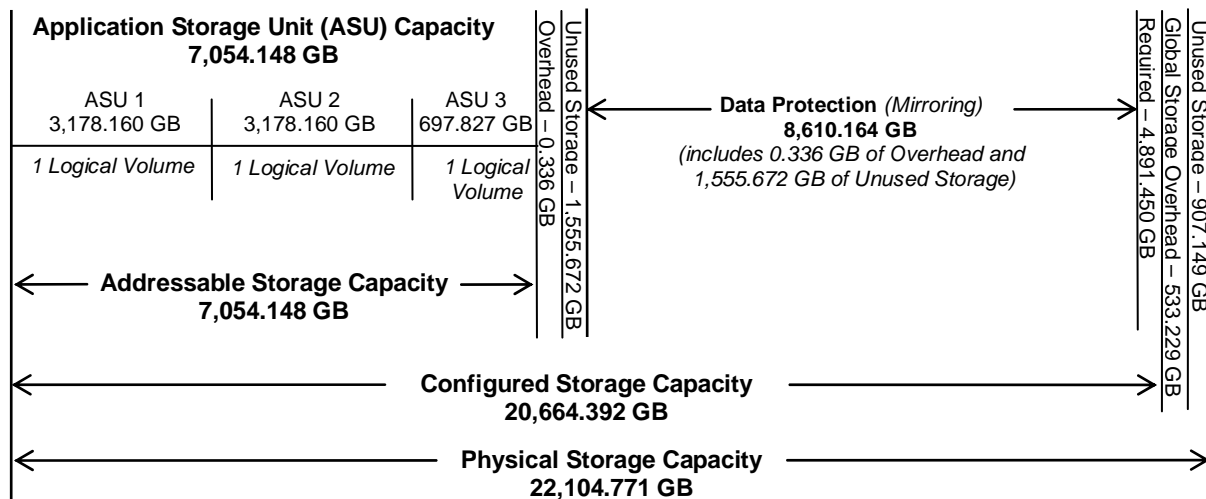

### Response Time – Throughput Curve

The Response Time-Throughput Curve illustrates the Average Response Time (milliseconds) and I/O Request Throughput at 100%, 95%, 90%, 80%, 50%, and 10% of the workload level used to generate the SPC-1 IOPS™ metric.

The Average Response Time measured at any of the above load points cannot exceed 30 milliseconds or the benchmark measurement is invalid.

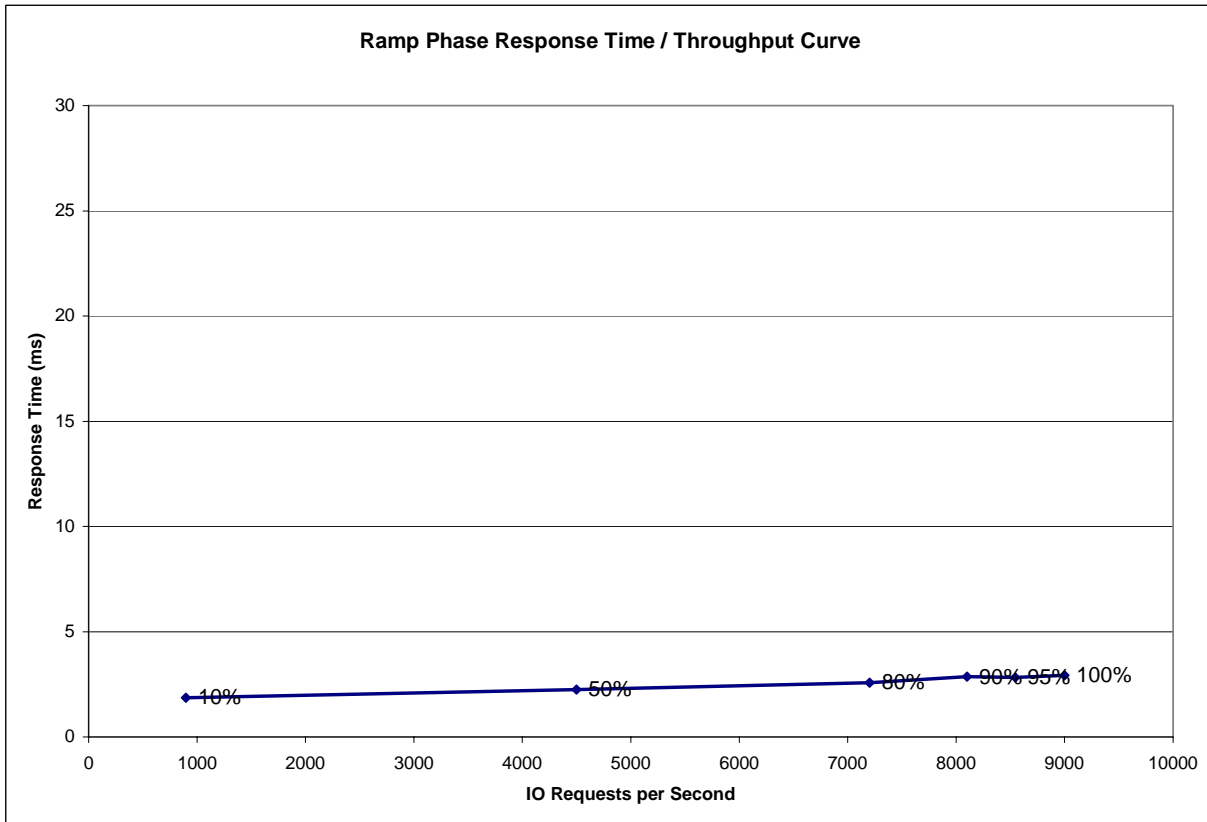

### Response Time – Throughput Data

	10% Load	50% Load	80% Load	90% Load	95% Load	100% Load
<b>I/O Request Throughput</b>	898.75	4,499.35	7,200.94	8,100.50	8,545.80	8,997.17
<b>Average Response Time (ms):</b>						
All ASUs	1.86	2.25	2.57	2.85	2.83	2.92
ASU-1	2.47	2.90	3.24	3.54	3.52	3.61
ASU-2	1.58	1.93	2.30	2.58	2.56	2.65
ASU-3	0.67	1.02	1.26	1.53	1.49	1.56
Reads	3.90	4.40	4.88	5.20	5.20	5.32
Writes	0.53	0.85	1.07	1.32	1.28	1.35

## Tested Storage Configuration Pricing (*Priced Storage Configuration*)

Qty	Product	U/M	Unit List	Discount	Total	Vendor
1	CX3-40C-FD - SPE-FIELD INSTALL	EA	\$42,300	0%	\$42,300	see attached third party quotation
11	CX-4PDAE-FD - 4G DAE FIELD INSTALL	EA	\$5,900	0%	\$64,900	see attached third party quotation
150	CX-4G15-146 - 146GB 15K 4GB FC	EA	\$1,645	0%	\$246,750	see attached third party quotation
1	V-CX4014615K - VAULT PACK CX3-40 146GB 15K 4GB DRIVES QTY 5	EA	\$8,225	0%	\$8,225	see attached third party quotation
4	FC2-HSSDC-8M - 8M HSSDC2 to HSSDC2 bus cbl	EA	\$600	0%	\$2,400	see attached third party quotation
1	PP-WN-KIT - POWERPATH WINDOWS KIT	EA	\$0	0%	\$0	see attached third party quotation
1	NAV-ENKIT - NAVI ENTERPRISE MEDIA	EA	\$0	0%	\$0	see attached third party quotation
8	NAVAGT-WINKIT - NAVI AGENT WINDOWS MEDIA	EA	\$0	0%	\$0	see attached third party quotation
1	SV3-KIT - SNAPVIEW MEDIA CX3-XX SER	EA	\$0	0%	\$0	see attached third party quotation
8	UTIL-WIN - Windows Software Utilities	EA	\$40	0%	\$320	see attached third party quotation
1	CX34C-KIT - CS3-40C DOCS AND RTU KIT	EA	\$0	0%	\$0	see attached third party quotation
1	C-MODEM-US - CLARIION SERVICE MODEM-US	EA	\$0	0%	\$0	see attached third party quotation
1	NAV34-EN - NAVI MGR CX3-40 ENTPR LIC	EA	\$58,000	0%	\$58,000	see attached third party quotation
1	SV34 - SNAPVIEW CX3-40	EA	\$17,400	0%	\$17,400	see attached third party quotation
1	PP-WN-WG - PPATH WINDOWS WGR	EA	\$1,440	0%	\$1,440	see attached third party quotation
1	PS-BAS-PP1 - POWERPATH 1HOST QS	EA	\$1,330	0%	\$1,330	see attached third party quotation
1	PS-BAS-PMBLK - POWERPATH 1HOST QS	EA	\$1,970	0%	\$1,970	see attached third party quotation
1	M-PRESW-001- premium software support	EA	\$33,929	0%	\$33,929	see attached third party quotation
1	M-PRESW-004 - premium software support - open SW	EA	\$777	0%	\$777	see attached third party quotation
1	WU-PREHW-001- premium hardware support	EA	\$31,317	0%	\$31,317	see attached third party quotation
2	QLA2462-E-SP - 2 PORT 4GB PCI-X	EA	\$1,700	0%	\$3,400	see attached third party quotation
2	Brocade 16-Port 200e FC Full Fab Switch,-C,R5	EA	\$8,700	0%	\$17,400	Network Appliance, Inc.
2	BSWITCH-16PORT-R5 HW Support,Premium,4hr,y	EA	\$1,697	0%	\$3,393	Network Appliance, Inc.
2	BSWITCH-16PORT-R5 SW Subs,Premium,4hr,y	EA	\$0	0%	\$0	Network Appliance, Inc.
	Hardware Total				\$385,375	
	Software Total				\$77,160	
	Services Total				\$3,300	
	prepaid software maintenance (3YR-4HOUR)				\$34,706	
	hardware warranty upgrade summary (3YR 4HOUR)				\$34,710	
	<b>Total Price</b>				<b>\$535,251</b>	

## Differences between the Tested Storage Configuration (TSC) and Priced Storage Configuration

The Tested Storage Configuration contained 154 disk drives and the Priced Storage Configuration contained 155 disk drives.

### Benchmark Configuration/Tested Storage Configuration Diagram

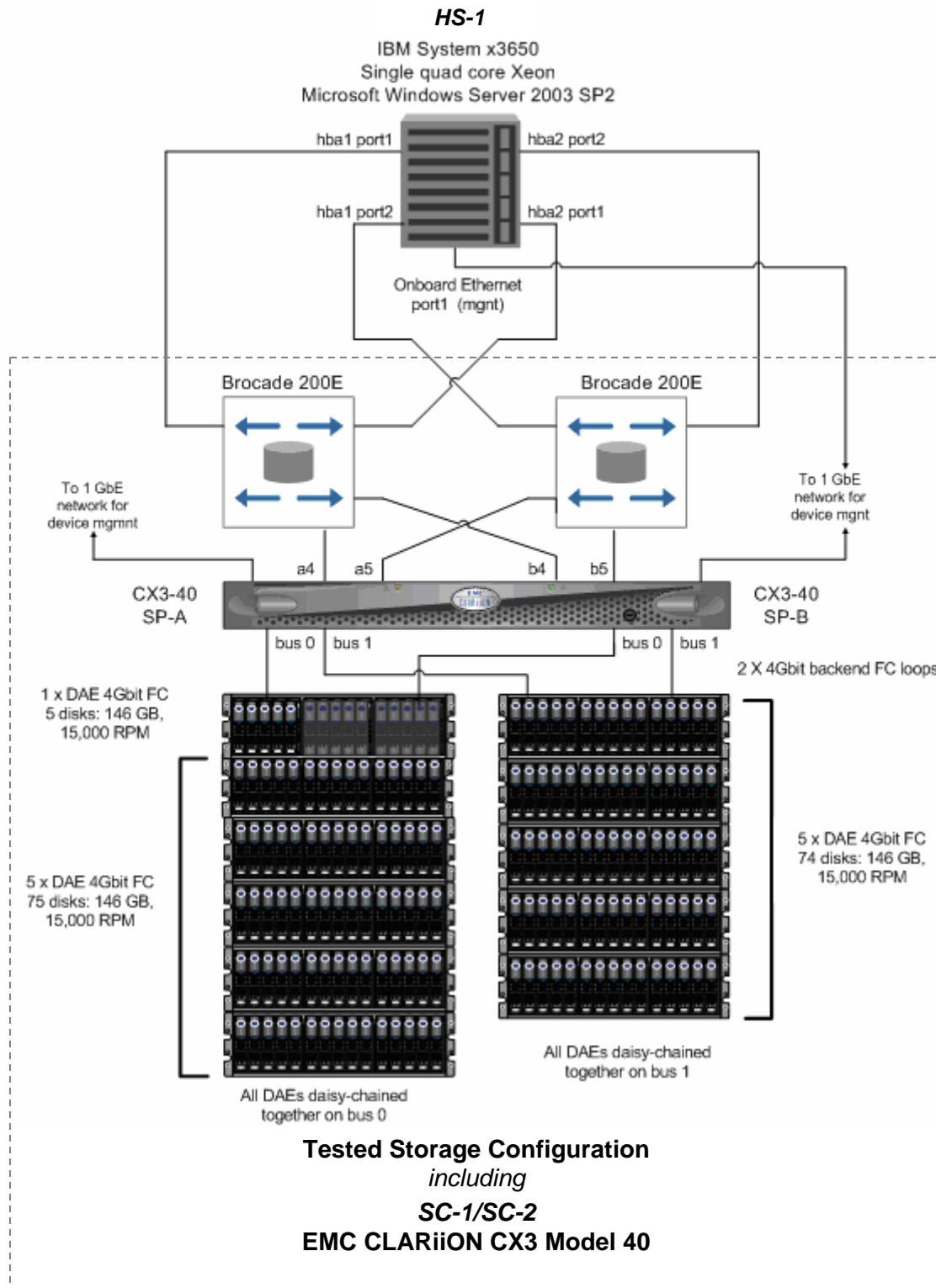

## Benchmark Configuration/Tested Storage Configuration Components

Host System:	Tested Storage Configuration (TSC):
<b>HS-1: IBM System x3650</b>	2 – Qlogic QLA2462-E, 2-Port, 4Gb, PCI-X HBAs
Single quad core Xeon processor	2 – Brocade 16-Port 200e FC switches
3 GHz CPUs, 8 MB cache per CPU	<b>SC-1/SC-2: EMC CLARiiON CX3 Model 40</b> 2 – storage controllers each with: 2 – Intel Xeon 2.8 GHz processors FLARE 03.26.040.5.005 4 GB main memory and cache 2 – 4Gb/s front-end ports 2 – 4Gb/s backend ports <b>SnapView™</b>
18 GB main memory	
Windows Server 2003 with SP2	
Priced Host System Software: Navisphere Powerpath Windows Kit 5.0	
PCI-X	154 – 146 GB 15K RPM disk drives
WG	

In each of the following sections of this document, the appropriate Full Disclosure Report requirement, from the SPC-1 benchmark specification, is stated in italics followed by the information to fulfill the stated requirement.

## **CONFIGURATION INFORMATION**

### **Benchmark Configuration (BC)/Tested Storage Configuration (TSC) Diagram**

#### **Clause 9.2.4.4.1**

*A one page Benchmark Configuration (BC)/Tested Storage Configuration (TSC) diagram shall be included in the Executive Summary...*

The Benchmark Configuration (BC)/Tested Storage Configuration (TSC) is illustrated on page 14 (*Benchmark Configuration/Tested Storage Configuration Diagram*).

### **Storage Network Configuration**

#### **Clause 9.2.4.4.1**

...

5. *If the TSC contains network storage, the diagram will include the network configuration. If a single diagram is not sufficient to illustrate both the Benchmark Configuration and network configuration in sufficient detail, the Benchmark Configuration diagram will include a high-level network illustration as shown in Figure 9-8. In that case, a separate, detailed network configuration diagram will also be included as described in Clause 9.2.4.4.2.*

#### **Clause 9.2.4.4.2**

*If a storage network was configured as a part of the Tested Storage Configuration and the Benchmark Configuration diagram described in Clause 9.2.4.4.1 contains a high-level illustration of the network configuration, the Executive Summary will contain a one page topology diagram of the storage network as illustrated in Figure 9-9.*

The Benchmark Configuration (BC)/Tested Storage Configuration (TSC), including the network configuration, is illustrated on page 14 (*Benchmark Configuration/Tested Storage Configuration Diagram*).

### **Host System Configuration**

#### **Clause 9.2.4.4.3**

*The FDR shall minimally contain, for each Host System running the Workload Generator, a listing of the following:*

1. *Number and type of CPUs.*
2. *Main memory capacity.*
3. *Cache memory capacity.*
4. *Number and type of disk controllers or Host Bus Adapters.*

The details of the Host System configuration may be found on page 14 (*Benchmark Configuration/Tested Storage Configuration Diagram*).

## Customer Tunable Parameters and Options

### Clause 9.2.4.5.1

*All Benchmark Configuration (BC) components with customer tunable parameter and options that have been altered from their default values must be listed in the FDR. The FDR entry for each of those components must include both the name of the component and the altered value of the parameter or option. If the parameter name is not self-explanatory to a knowledgeable practitioner, a brief description of the parameter's use must also be included in the FDR entry.*

“Appendix B: Customer Tunable Parameters and Options” on page 59 contains the customer tunable parameters and options that have been altered from their default values for this benchmark.

## Tested Storage Configuration (TSC) Description

### Clause 9.2.4.5.2

*The FDR must include sufficient information to recreate the logical representation of the TSC. In addition to customer tunable parameters and options (Clause 4.2.4.5.3), that information must include, at a minimum:*

- *A diagram and/or description of the following:*
  - *All physical components that comprise the TSC. Those components are also illustrated in the BC Configuration Diagram in Clause 9.2.4.4.1 and/or the Storage Network Configuration Diagram in Clause 9.2.4.4.2.*
  - *The logical representation of the TSC, configured from the above components that will be presented to the Workload Generator.*
- *Listings of scripts used to create the logical representation of the TSC.*
- *If scripts were not used, a description of the process used with sufficient detail to recreate the logical representation of the TSC.*

“Appendix C: Tested Storage Configuration (TSC) Creation” on page 60 contains the detailed information that describes how to create and configure the logical TSC.

## SPC-1 Workload Generator Storage Configuration

### Clause 9.2.4.5.3

*The FDR must include all SPC-1 Workload Generator storage configuration commands and parameters.*

The SPC-1 Workload Generator storage configuration commands and parameters for this measurement appear in “Appendix D: SPC-1 Workload Generator Storage Commands and Parameters” on page 66.

## SPC-1 DATA REPOSITORY

This portion of the Full Disclosure Report presents the detailed information that fully documents the various SPC-1 storage capacities and mappings used in the Tested Storage Configuration. “SPC-1 Data Repository Definitions” on page 55 contains definitions of terms specific to the SPC-1 Data Repository.

### Storage Capacities and Relationships

#### Clause 9.2.4.6.1

Two tables and an illustration documenting the storage capacities and relationships of the SPC-1 Storage Hierarchy (Clause 2.1) shall be included in the FDR.

#### SPC-1 Storage Capacities

SPC-1 Storage Capacities		
Storage Hierarchy Component	Units	Capacity
Total ASU Capacity	Gigabytes (GB)	7,054.148
Addressable Storage Capacity	Gigabytes (GB)	7,054.148
Configured Storage Capacity	Gigabytes (GB)	20,664.392
Physical Storage Capacity	Gigabytes (GB)	22,104.771
Data Protection ( <i>Mirroring</i> )	Gigabytes (GB)	8,610.164
Required Storage ( <i>spares/firmware drives/SnapView</i> )	Gigabytes (GB)	4,891.450
Global Storage Overhead	Gigabytes (GB)	533.229
Total Unused Storage	Gigabytes (GB)	4,018.493

#### SPC-1 Storage Hierarchy Ratios

	Addressable Storage Capacity	Configured Storage Capacity	Physical Storage Capacity
Total ASU Capacity	100.00%	34.14%	31.91%
Required for Data Protection ( <i>Mirroring</i> )		41.67%	38.95%
Addressable Storage Capacity		34.14%	31.91%
Required Storage		23.67%	22.13%
Configured Storage Capacity			93.48%
Global Storage Overhead			2.41%
Unused Storage:			
Addressable	0.00%		
Configured		15.06%	
Physical			4.10%

The Physical Storage Capacity consisted of 22,104.771 GB distributed over 154 disk drives each with a formatted capacity of 144.738 GB. There was 907.149 GB (4.10%) of Unused Storage within the Physical Storage Capacity. Global Storage Overhead consisted of 533.229 GB (2.41%) of Physical Storage Capacity. A total of 3,444.065 GB was allocated within the Configured Storage Capacity (*Required category*) for SnapView™. There was 3,111.344 GB (15.06%) of Unused Storage within the Configured Storage Capacity. The Total ASU Capacity utilized 100.00% of the Addressable Storage Capacity resulting in 0.000 GB (0.00%) of Unused Storage within the Addressable Storage Capacity.

**SPC-1 Storage Capacities and Relationships Illustration**

The various storage capacities configured in the benchmark result are illustrated below (not to scale).

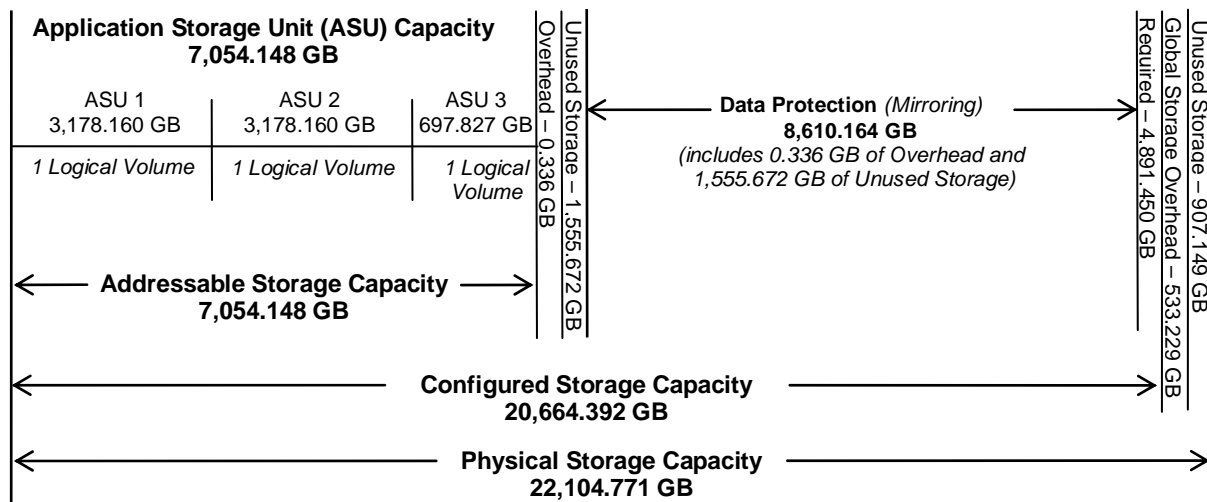

**Logical Volume Capacity and ASU Mapping**

*Clause 9.2.4.6.2*

A table illustrating the capacity of each ASU and the mapping of Logical Volumes to ASUs shall be provided in the FDR. ... Logical Volumes shall be sequenced in the table from top to bottom per its position in the contiguous address space of each ASU. The capacity of each Logical Volume shall be stated. ... In conjunction with this table, the Test Sponsor shall provide a complete description of the type of data protection (see Clause 2.4.5) used on each Logical Volume.

Logical Volume Capacity and Mapping		
ASU-1 (3,178.160 GB)	ASU-2 (3,178.160 GB)	ASU-3 (697.827 GB)
1 Logical Volume 3,178.160 GB per Logical Volume (,178.160 GB used per Logical Volume)	1 Logical Volume ,178.160 GB per Logical Volume (,178.160 GB used per Logical Volume)	1 Logical Volume 697.827 GB per Logical Volume (697.827 GB used per Logical Volume)

The Data Protection Level used for all Logical Volumes was Mirroring as described on page 11. See “ASU Configuration” in the [IOPS Test Results File](#) for more detailed configuration information.

## **SPC-1 BENCHMARK EXECUTION RESULTS**

This portion of the Full Disclosure Report documents the results of the various SPC-1 Tests, Test Phases, and Test Runs. “SPC-1 Test Execution Definitions” on page 56 contains definitions of terms specific to the SPC-1 Tests, Test Phases, and Test Runs.

### ***Clause 5.4.3***

*The Tests must be executed in the following sequence: Primary Metrics, Repeatability, and Data Persistence. That required sequence must be uninterrupted from the start of Primary Metrics to the completion of Persistence Test Run 1. Uninterrupted means the Benchmark Configuration shall not be power cycled, restarted, disturbed, altered, or adjusted during the above measurement sequence. If the required sequence is interrupted other than for the Host System/TSC power cycle between the two Persistence Test Runs, the measurement is invalid.*

## **SPC-1 Tests, Test Phases, and Test Runs**

The SPC-1 benchmark consists of the following Tests, Test Phases, and Test Runs:

- **Primary Metrics Test**
  - Sustainability Test Phase and Test Run
  - IOPS Test Phase and Test Run
  - Response Time Ramp Test Phase
    - 95% of IOPS Test Run
    - 90% of IOPS Test Run
    - 80% of IOPS Test Run
    - 50% of IOPS Test Run
    - 10% of IOPS Test Run (LRT)
- **Repeatability Test**
  - Repeatability Test Phase 1
    - 10% of IOPS Test Run (LRT)
    - IOPS Test Run
  - Repeatability Test Phase 2
    - 10% of IOPS Test Run (LRT)
    - IOPS Test Run
- **Data Persistence Test**
  - Data Persistence Test Run 1
  - Data Persistence Test Run 2

Each Test is an atomic unit that must be executed from start to finish before any other Test, Test Phase, or Test Run may be executed.

The results from each Test, Test Phase, and Test Run are listed below along with a more detailed explanation of each component.

## Primary Metrics Test – Sustainability Test Phase

### Clause 5.4.4.1.1

*The Sustainability Test Phase has exactly one Test Run and shall demonstrate the maximum sustainable I/O Request Throughput within at least a continuous three (3) hour Measurement Interval. This Test Phase also serves to insure that the TSC has reached Steady State prior to reporting the final maximum I/O Request Throughput result (SPC-1 IOPS™).*

### Clause 5.4.4.1.2

*The computed I/O Request Throughput of the Sustainability Test must be within 5% of the reported SPC-1 IOPS™ result.*

### Clause 5.4.4.1.4

*The Average Response Time, as defined in Clause 5.1.1, will be computed and reported for the Sustainability Test Run and cannot exceed 30 milliseconds. If the Average Response time exceeds that 30-milliseconds constraint, the measurement is invalid.*

### Clause 9.2.4.7.1

*For the Sustainability Test Phase the FDR shall contain:*

- 1. A Data Rate Distribution graph and data table.*
- 2. I/O Request Throughput Distribution graph and data table.*
- 3. A Response Time Frequency Distribution graph and table.*
- 4. An Average Response Time Distribution graph and table.*
- 5. The human readable Test Run Results File produced by the Workload Generator (may be included in an appendix).*
- 6. A listing or screen image of all input parameters supplied to the Workload Generator (may be included in an appendix).*
- 7. The Measured Intensity Multiplier for each I/O stream.*
- 8. The variability of the Measured Intensity Multiplier, as defined in Clause 5.3.13.3.*

## SPC-1 Workload Generator Input Parameters

The SPC-1 Workload Generator input parameters for the Sustainability, IOPS, Response Time Ramp, Repeatability, and Persistence Test Runs are documented in “Appendix E: SPC-1 Workload Generator Input Parameters” on Page 67.

## Sustainability Test Results File

A link to the test results file generated from the Sustainability Test Run is listed below.

[Sustainability Test Results File](#)

**Sustainability – Data Rate Distribution Data (MB/second)**

Ramp-Up/Start-Up Measurement Interval		Start	Stop	Interval	Duration															
		15:23:50	15:26:50	0-2	0:03:00															
		15:26:50	18:26:50	3-182	3:00:00															
Interval	All ASUs	ASU1	ASU2	ASU3	Interval	All ASUs	ASU1	ASU2	ASU3	Interval	All ASUs	ASU1	ASU2	ASU3						
0	73.87	28.67	7.84	37.37	63	67.34	26.17	7.08	34.10	126	56.03	21.70	5.95	28.37						
1	73.73	28.68	7.91	37.14	64	54.19	20.99	5.73	27.47	127	55.77	21.59	6.00	28.18						
2	73.93	28.63	7.82	37.48	65	53.77	20.90	5.75	27.11	128	57.90	22.49	6.15	29.26						
3	73.85	28.70	7.82	37.32	66	46.65	18.01	5.07	23.57	129	61.46	23.90	6.53	31.02						
4	73.63	28.72	7.81	37.10	67	57.56	22.31	6.17	29.07	130	60.99	23.77	6.46	30.76						
5	73.91	28.72	7.87	37.32	68	56.60	21.92	6.05	28.64	131	60.95	23.74	6.49	30.73						
6	74.13	28.69	7.93	37.51	69	58.21	22.67	6.20	29.35	132	64.23	25.02	6.95	32.26						
7	73.92	28.82	7.80	37.31	70	60.15	23.28	6.43	30.44	133	58.89	22.84	6.28	29.77						
8	73.89	28.82	7.84	37.23	71	63.82	24.90	6.80	32.12	134	63.81	24.84	6.85	32.12						
9	73.83	28.67	7.81	37.36	72	61.52	23.78	6.48	31.26	135	62.50	24.31	6.73	31.45						
10	73.62	28.65	7.98	37.00	73	58.31	22.71	6.21	29.38	136	67.05	26.04	7.11	33.91						
11	73.90	28.71	7.84	37.35	74	63.76	24.74	6.80	32.22	137	65.90	25.47	6.97	33.46						
12	73.94	28.81	7.91	37.22	75	64.87	25.28	6.95	32.64	138	67.72	26.30	7.17	34.26						
13	73.76	28.65	7.82	37.29	76	66.05	25.54	7.12	33.39	139	63.59	24.67	6.71	32.21						
14	73.69	28.65	7.79	37.25	77	64.54	25.10	6.91	32.54	140	66.44	25.72	7.08	33.64						
15	73.66	28.56	7.90	37.19	78	60.94	23.75	6.53	30.65	141	68.00	26.35	7.28	34.37						
16	73.93	28.71	7.89	37.33	79	67.02	25.94	7.18	33.90	142	66.00	25.63	7.07	33.30						
17	74.16	28.68	7.94	37.54	80	63.40	24.60	6.72	32.09	143	68.68	26.67	7.36	34.65						
18	73.66	28.66	7.90	37.09	81	68.02	26.35	7.27	34.40	144	69.08	26.85	7.40	34.83						
19	73.82	28.56	7.92	37.34	82	65.32	25.41	6.98	32.94	145	68.45	26.60	7.32	34.53						
20	73.72	28.79	7.82	37.11	83	63.52	24.69	6.80	32.03	146	69.90	27.07	7.46	35.36						
21	74.12	28.77	7.90	37.46	84	63.78	24.83	6.76	32.19	147	70.03	27.26	7.46	35.31						
22	74.13	28.67	7.88	37.58	85	69.03	26.73	7.41	34.89	148	65.39	25.48	7.03	32.88						
23	73.91	28.67	7.77	37.48	86	67.94	26.39	7.32	34.23	149	70.33	27.26	7.52	35.55						
24	73.93	28.82	7.84	37.27	87	68.52	26.66	7.39	34.47	150	68.47	26.71	7.33	34.43						
25	74.09	28.60	7.98	37.51	88	69.98	27.25	7.52	35.20	151	69.86	27.08	7.43	35.36						
26	73.85	28.59	7.95	37.31	89	70.04	27.18	7.51	35.34	152	71.83	27.90	7.62	36.31						
27	73.66	28.65	7.75	37.26	90	71.80	27.83	7.71	36.26	153	67.82	26.45	7.29	34.08						
28	73.67	28.60	7.85	37.22	91	68.98	26.83	7.37	34.78	154	68.38	26.50	7.36	34.53						
29	74.09	28.64	7.92	37.53	92	67.76	26.29	7.24	34.23	155	73.76	28.60	7.81	37.34						
30	73.93	28.67	7.91	37.34	93	70.22	27.18	7.43	35.61	156	66.03	25.72	7.03	33.28						
31	73.71	28.63	7.87	37.20	94	71.16	27.77	7.62	35.77	157	73.52	28.57	7.83	37.13						
32	74.11	28.89	7.79	37.43	95	72.36	28.19	7.66	36.51	158	73.61	28.47	7.88	37.27						
33	73.87	28.62	7.98	37.27	96	70.56	27.33	7.66	35.56	159	68.02	26.42	7.31	34.30						
34	74.04	28.62	7.98	37.45	97	70.07	27.13	7.46	35.47	160	71.25	27.64	7.63	35.98						
35	73.73	28.64	7.80	37.29	98	74.82	29.04	7.92	37.86	161	71.89	27.86	7.67	36.35						
36	73.85	28.59	7.89	37.37	99	71.87	27.88	7.63	36.37	162	64.95	25.26	6.97	32.71						
37	73.79	28.57	7.93	37.29	100	73.71	28.60	7.99	37.12	163	70.29	27.21	7.47	35.60						
38	73.72	28.72	7.84	37.16	101	75.76	29.59	8.06	38.11	164	73.02	28.35	7.69	36.98						
39	74.01	28.64	7.94	37.42	102	71.56	27.74	7.57	36.25	165	74.82	29.13	7.98	37.71						
40	73.77	28.63	7.86	37.29	103	72.89	28.29	7.77	36.83	166	74.22	28.99	7.99	37.24						
41	73.77	28.68	7.87	37.22	104	72.31	28.03	7.71	36.56	167	72.35	27.99	7.69	36.67						
42	73.92	28.80	7.94	37.18	105	74.91	29.19	7.98	37.74	168	79.77	30.99	8.49	40.29						
43	73.87	28.63	7.89	37.34	106	69.32	26.97	7.49	34.85	169	74.24	28.86	7.90	37.48						
44	73.66	28.70	7.88	37.08	107	71.51	27.77	7.63	36.10	170	79.34	30.81	8.38	40.14						
45	73.91	28.69	7.81	37.41	108	78.96	30.71	8.47	39.78	171	78.14	30.38	8.37	39.39						
46	73.89	28.76	7.92	37.21	109	75.86	29.30	8.03	38.53	172	77.29	29.87	8.20	39.22						
47	74.10	28.54	7.98	37.58	110	76.81	29.90	8.27	38.64	173	75.83	29.47	8.12	38.24						
48	73.85	28.50	7.90	37.45	111	79.55	30.92	8.50	40.13	174	78.01	30.29	8.36	39.36						
49	74.04	28.72	7.84	37.48	112	79.19	30.88	8.45	39.86	175	79.27	30.82	8.44	40.00						
50	73.90	28.70	7.85	37.35	113	72.29	28.14	7.73	36.43	176	80.14	31.07	8.51	40.56						
51	73.77	28.73	7.87	37.18	114	79.65	30.84	8.59	40.23	177	77.10	30.06	8.19	38.86						
52	73.91	28.68	7.86	37.37	115	74.67	28.91	7.94	37.82	178	80.50	31.07	8.56	40.86						
53	74.08	28.72	7.95	37.40	116	76.01	29.63	8.13	38.24	179	79.11	30.82	8.40	39.90						
54	73.80	28.64	7.82	37.34	117	77.23	29.86	8.24	39.13	180	184.07	71.47	19.70	92.91						
55	73.52	28.59	7.85	37.08	118	77.16	30.12	8.20	38.84	181	190.99	74.20	20.48	96.32						
56	73.94	28.71	7.91	37.32	119	202.07	78.37	21.60	102.11	182	103.58	40.07	11.03	52.48						
57	73.97	28.74	7.94	37.29	120	137.28	53.25	14.69	69.33											
58	73.93	28.75	7.96	37.22	121	116.84	45.38	12.35	59.11											
59	73.69	28.68	7.85	37.17	122	101.43	39.25	10.94	51.23											
60	73.91	28.61	7.98	37.31	123	94.86	36.74	10.11	48.00											
61	73.73	28.55	7.87	37.31	124	77.04	29.95	8.20	38.88											
62	69.46	26.97	7.37	35.12	125	54.45	21.20	5.81	27.44											

### Sustainability – Data Rate Distribution Graph

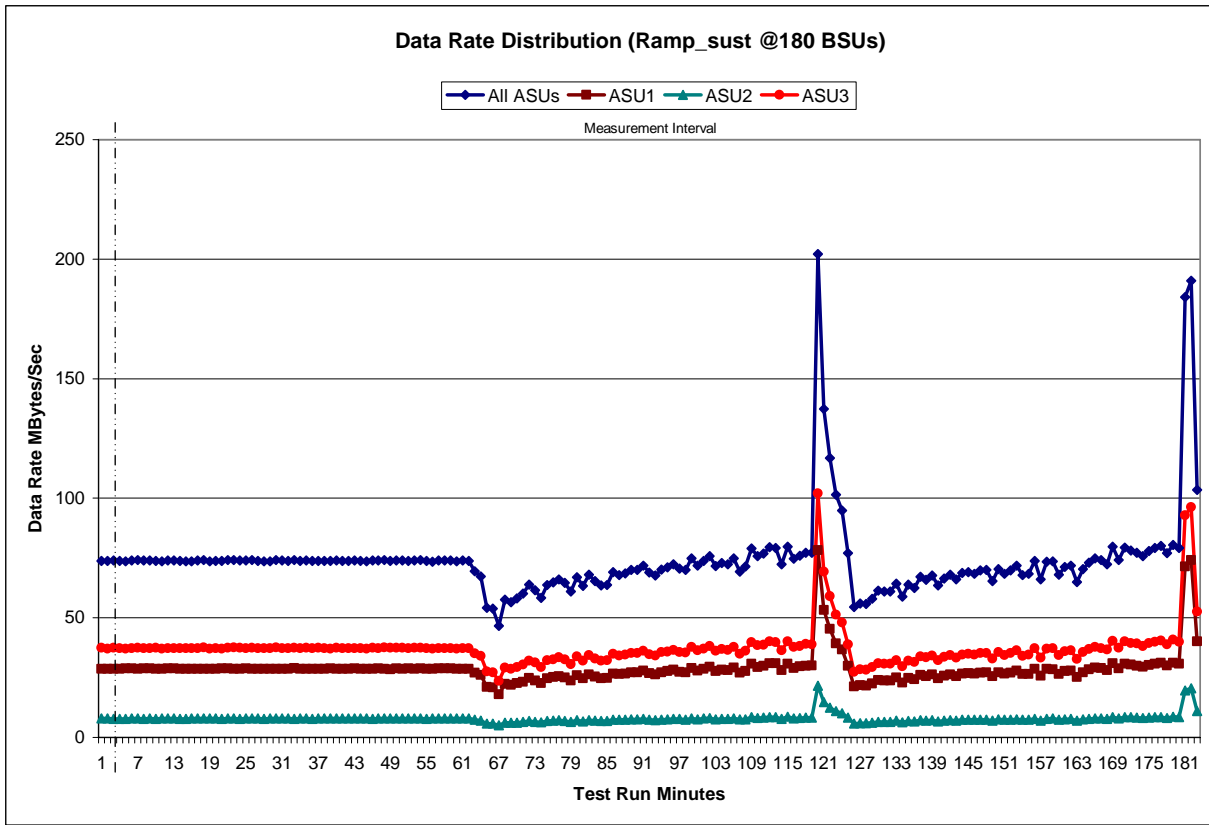

**Sustainability – I/O Request Throughput Distribution Data**

Ramp-Up/Start-Up Measurement Interval	Start	Stop	Interval	Duration										
	15:23:50	15:26:50	0-2	0:03:00										
	15:26:50	18:26:50	3-182	3:00:00										
Interval	All ASUs	ASU1	ASU2	ASU3	Interval	All ASUs	ASU1	ASU2	ASU3	Interval	All ASUs	ASU1	ASU2	
0	8,989.27	5,360.57	1,103.37	2,525.33	63	8,203.13	4,894.42	1,000.27	2,308.45	126	6,824.72	4,068.28	835.55	
1	9,008.75	5,365.97	1,116.12	2,526.67	64	6,597.35	3,933.72	805.82	1,857.82	127	6,786.88	4,041.95	837.00	
2	9,003.03	5,361.60	1,111.80	2,529.63	65	6,571.47	3,914.08	810.18	1,847.20	128	7,053.23	4,201.20	868.58	
3	8,993.25	5,362.25	1,097.62	2,533.38	66	5,684.93	3,388.72	702.02	1,594.20	129	7,482.57	4,463.92	920.55	
4	9,000.25	5,374.50	1,099.33	2,526.42	67	7,033.20	4,189.97	864.95	1,978.28	130	7,465.83	4,447.75	917.22	
5	9,018.63	5,369.97	1,112.38	2,536.28	68	6,881.02	4,097.90	846.93	1,936.18	131	7,460.30	4,454.92	916.12	
6	9,019.82	5,376.78	1,108.05	2,534.98	69	7,091.13	4,232.08	868.20	1,990.85	132	7,858.37	4,683.70	969.55	
7	9,005.88	5,361.47	1,109.05	2,535.37	70	7,322.80	4,359.87	906.18	2,056.75	133	7,186.75	4,284.87	881.15	
8	9,006.82	5,376.83	1,103.90	2,526.08	71	7,783.40	4,634.53	962.18	2,186.68	134	7,780.10	4,637.57	960.35	
9	8,988.87	5,360.92	1,100.45	2,527.50	72	7,476.20	4,452.68	917.40	2,106.12	135	7,621.62	4,539.17	937.42	
10	8,995.32	5,355.67	1,112.40	2,527.25	73	7,099.08	4,237.70	870.98	1,990.40	136	8,163.43	4,865.53	1,006.58	
11	9,016.45	5,377.83	1,107.97	2,530.65	74	7,743.50	4,615.62	948.53	2,179.35	137	8,024.22	4,780.82	986.73	
12	9,006.98	5,367.47	1,106.60	2,532.92	75	7,913.07	4,714.40	974.62	2,224.05	138	8,243.42	4,917.13	1,009.68	
13	8,979.50	5,350.68	1,096.03	2,532.78	76	8,046.42	4,783.18	996.38	2,266.85	139	7,754.63	4,625.57	950.77	
14	8,976.48	5,348.32	1,099.60	2,528.57	77	7,849.78	4,680.93	965.73	2,203.12	140	8,112.68	4,831.53	992.60	
15	8,982.95	5,353.45	1,106.95	2,522.55	78	7,435.17	4,436.98	913.05	2,085.13	141	8,274.07	4,927.13	1,018.68	
16	9,016.92	5,376.22	1,102.33	2,538.37	79	8,154.43	4,858.63	1,005.98	2,289.82	142	8,050.63	4,796.65	991.45	
17	9,000.30	5,353.08	1,111.70	2,535.52	80	7,716.67	4,590.20	948.82	2,177.65	143	8,397.30	5,004.93	1,039.92	
18	9,008.32	5,368.73	1,108.77	2,530.82	81	8,259.70	4,923.88	1,017.42	2,318.40	144	8,408.23	5,012.53	1,030.78	
19	9,002.28	5,365.38	1,103.33	2,533.57	82	7,974.08	4,752.92	979.72	2,241.45	145	8,347.82	4,979.38	1,024.42	
20	9,012.67	5,378.63	1,104.88	2,529.15	83	7,723.00	4,609.53	951.02	2,162.45	146	8,525.88	5,077.08	1,047.08	
21	8,986.20	5,350.13	1,107.90	2,528.17	84	7,784.22	4,637.97	956.70	2,189.55	147	8,536.17	5,095.75	1,053.67	
22	9,016.63	5,375.40	1,105.18	2,536.05	85	8,404.72	5,003.93	1,037.65	2,363.13	148	7,979.00	4,757.10	984.25	
23	8,996.53	5,361.70	1,100.43	2,534.40	86	8,279.45	4,931.52	1,023.85	2,324.08	149	8,547.60	5,093.15	1,050.68	
24	9,014.93	5,371.03	1,107.23	2,536.67	87	8,388.63	5,000.38	1,031.98	2,356.27	150	8,344.25	4,977.37	1,024.55	
25	9,013.58	5,364.40	1,110.83	2,538.35	88	8,569.75	5,108.98	1,054.27	2,406.50	151	8,503.22	5,075.57	1,036.58	
26	8,991.27	5,358.38	1,108.02	2,524.87	89	8,537.90	5,082.48	1,047.48	2,407.93	152	8,728.83	5,204.98	1,069.58	
27	8,996.58	5,372.50	1,096.20	2,527.88	90	8,728.47	5,206.37	1,070.75	2,451.35	153	8,270.77	4,935.92	1,013.88	
28	8,972.48	5,348.98	1,102.18	2,521.32	91	8,407.47	5,024.57	1,033.43	2,349.47	154	8,317.08	4,953.67	1,024.78	
29	9,004.22	5,359.23	1,110.60	2,534.38	92	8,263.55	4,927.12	1,016.22	2,320.22	155	8,986.20	5,349.05	1,098.25	
30	9,011.88	5,369.12	1,106.40	2,536.37	93	8,541.75	5,081.97	1,044.58	2,415.20	156	8,052.15	4,801.65	991.82	
31	8,973.43	5,348.00	1,100.67	2,524.77	94	8,670.40	5,175.25	1,065.25	2,429.90	157	8,962.23	5,342.18	1,098.95	
32	9,004.63	5,372.30	1,102.33	2,530.00	95	8,826.00	5,267.18	1,081.00	2,477.82	158	8,941.62	5,325.75	1,107.77	
33	8,997.52	5,360.52	1,118.45	2,518.55	96	8,593.20	5,120.92	1,065.80	2,406.48	159	8,303.43	4,951.97	1,021.08	
34	8,985.75	5,350.68	1,107.27	2,527.80	97	8,507.10	5,065.28	1,041.68	2,400.13	160	8,678.95	5,169.07	1,073.32	
35	9,004.77	5,362.95	1,109.35	2,532.47	98	9,111.55	5,428.02	1,118.27	2,565.27	161	8,740.77	5,210.95	1,070.40	
36	9,005.10	5,364.13	1,104.73	2,536.23	99	8,738.53	5,211.20	1,072.78	2,454.55	162	7,940.02	4,733.98	979.47	
37	8,993.47	5,357.23	1,104.85	2,531.38	100	8,987.38	5,349.98	1,106.93	2,530.47	163	8,532.03	5,081.30	1,046.82	
38	8,990.28	5,366.15	1,102.80	2,521.33	101	9,230.03	5,506.58	1,128.73	2,594.72	164	8,893.47	5,294.08	1,087.18	
39	8,989.60	5,351.20	1,112.88	2,525.52	102	8,686.07	5,171.43	1,071.05	2,443.58	165	9,114.28	5,435.90	1,116.13	
40	9,002.77	5,364.68	1,107.77	2,530.32	103	8,905.55	5,307.90	1,094.50	2,503.15	166	9,065.22	5,407.67	1,121.30	
41	9,005.57	5,373.90	1,104.80	2,526.87	104	8,813.93	5,254.25	1,079.32	2,480.37	167	8,802.48	5,247.87	1,083.68	
42	9,009.62	5,369.08	1,108.35	2,532.18	105	9,177.52	5,478.05	1,126.47	2,573.00	168	9,702.22	5,787.27	1,186.62	
43	8,996.05	5,358.78	1,109.27	2,528.00	106	8,428.77	5,020.70	1,041.23	2,366.83	169	9,023.90	5,373.10	1,116.73	
44	8,968.15	5,348.25	1,099.05	2,520.85	107	8,701.40	5,187.52	1,068.10	2,445.78	170	9,675.23	5,773.88	1,183.43	
45	9,002.40	5,365.75	1,101.48	2,535.17	108	9,630.05	5,737.43	1,185.47	2,707.15	171	9,507.52	5,660.90	1,172.43	
46	9,001.58	5,366.22	1,106.07	2,529.30	109	9,234.48	5,490.25	1,135.57	2,608.67	172	9,411.82	5,609.07	1,151.32	
47	9,001.43	5,354.75	1,107.47	2,539.22	110	9,351.97	5,572.72	1,155.08	2,624.17	173	9,260.27	5,521.48	1,135.93	
48	8,981.12	5,340.95	1,110.28	2,529.88	111	9,712.52	5,803.83	1,193.52	2,715.17	174	9,518.25	5,680.00	1,168.32	
49	9,005.00	5,371.43	1,105.72	2,527.85	112	9,694.07	5,783.33	1,193.92	2,716.82	175	9,672.82	5,766.50	1,194.08	
50	8,993.23	5,363.30	1,101.22	2,528.72	113	8,790.28	5,239.97	1,083.02	2,467.30	176	9,741.75	5,808.40	1,196.68	
51	8,987.38	5,351.18	1,109.55	2,526.65	114	9,690.13	5,767.32	1,190.98	2,731.83	177	9,392.85	5,604.27	1,158.13	
52	8,998.77	5,364.40	1,106.53	2,527.83	115	9,103.08	5,424.90	1,119.18	2,559.00	178	9,769.97	5,812.28	1,201.23	
53	9,008.42	5,370.17	1,109.53	2,528.72	116	9,289.72	5,545.33	1,137.72	2,606.67	179	9,643.58	5,763.35	1,182.22	
54	8,992.58	5,359.47	1,107.32	2,525.80	117	9,387.12	5,586.30	1,154.43	2,646.38	180	22,371.33	13,323.12	2,755.23	
55	9,001.08	5,358.62	1,107.42	2,535.05	118	9,433.20	5,626.20	1,161.48	2,645.52	181	23,240.23	13,846.75	2,871.93	
56	8,987.58	5,354.87	1,110.07	2,522.65	119	24,616.72	14,668.60	3,022.18	6,925.93	182	12,579.32	7,489.93	1,550.30	
57	9,009.30	5,364.47	1,111.87	2,532.97	120	16,729.53	9,969.63	2,056.00	4,703.90	Average	8,992.59	5,359.43	1,105.61	
58	9,003.53	5,365.27	1,114.67	2,523.60	121	14,240.90	8,484.87	1,747.97	4,008.07					
59	9,000.97	5,369.45	1,102.73	2,528.78	122	12,368.18	7,356.57	1,527.12	3,484.50					
60	9,002.55	5,364.85	1,107.40	2,530.30	123	11,523.27	6,867.77	1,417.37	3,238.13					
61	8,999.40	5,354.38	1,112.47	2,532.55	124	9,376.02	5,590.80	1,149.28	2,635.93					
62	8,471.97	5,047.58	1,036.77	2,387.62	125	6,666.93	3,982.12	816.38	1,868.43					

### Sustainability – I/O Request Throughput Distribution Graph

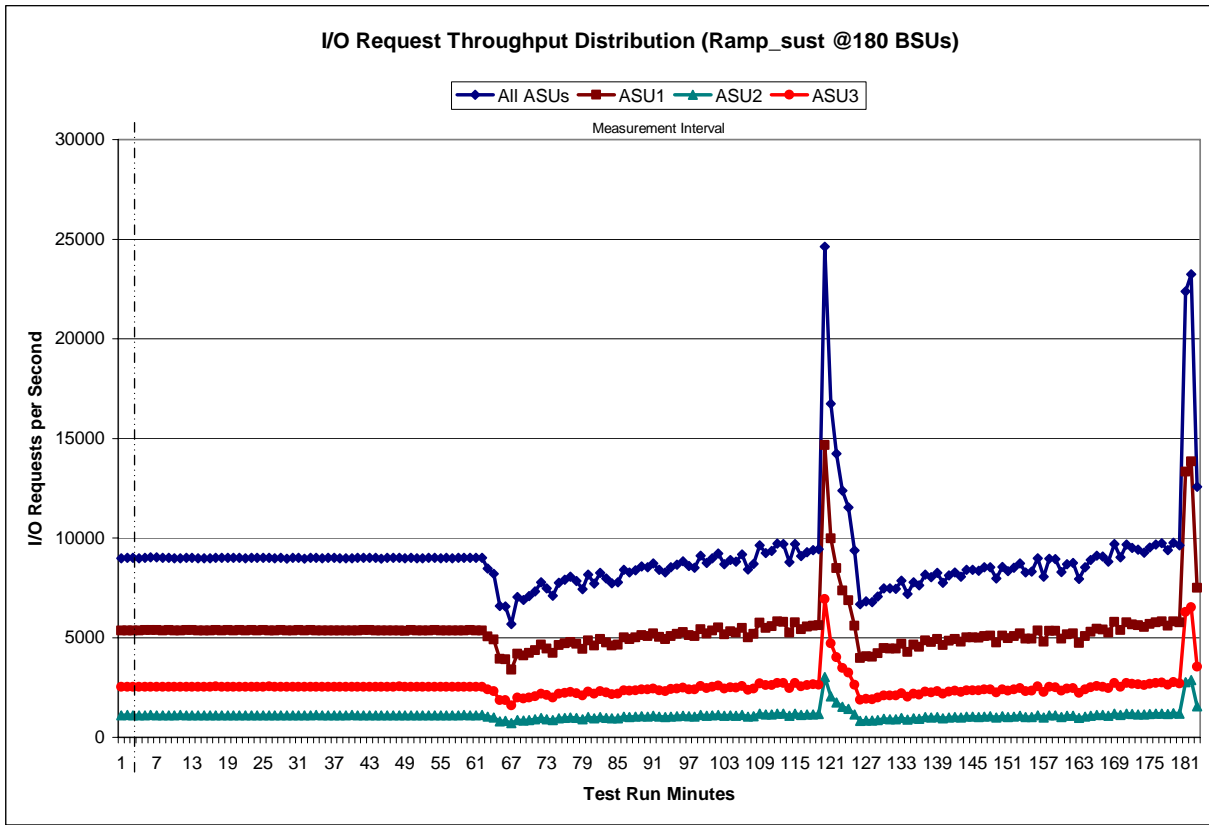

**Sustainability – Average Response Time (ms) Distribution Data**

	Start	Stop	Interval	Duration										
Ramp-Up/Start-Up	15:23:50	15:26:50	0-2	0:03:00										
Measurement Interval	15:26:50	18:26:50	3-182	3:00:00										
Interval	All ASUs	ASU1	ASU2	ASU3	Interval	All ASUs	ASU1	ASU2	ASU3	Interval	All ASUs	ASU1	ASU2	ASU3
0	2.95	3.62	2.90	1.55	63	34.39	47.08	16.21	15.37	126	52.69	78.82	18.73	12.11
1	2.88	3.58	2.55	1.53	64	54.55	81.49	20.62	12.21	127	53.20	79.50	18.87	12.53
2	2.93	3.63	2.68	1.58	65	55.99	84.38	21.24	11.06	128	50.90	76.32	17.95	11.48
3	2.90	3.59	2.64	1.56	66	61.90	95.29	15.94	11.14	129	48.08	71.14	19.91	11.35
4	2.91	3.61	2.63	1.56	67	51.11	76.32	20.02	11.31	130	48.20	67.13	39.75	11.82
5	2.94	3.63	2.67	1.58	68	52.40	78.35	18.94	12.11	131	48.22	71.68	19.32	10.88
6	2.97	3.67	2.70	1.62	69	50.74	71.31	38.62	12.31	132	45.78	66.56	22.67	11.83
7	2.90	3.60	2.61	1.55	70	49.09	72.78	19.75	11.82	133	50.23	70.26	41.86	11.40
8	2.94	3.63	2.67	1.57	71	46.30	67.76	19.37	12.67	134	46.13	67.93	19.03	11.72
9	2.91	3.61	2.62	1.55	72	48.19	71.40	19.37	11.68	135	47.21	69.58	19.06	12.17
10	2.90	3.60	2.62	1.55	73	52.71	74.05	41.36	12.23	136	44.13	63.98	21.28	12.00
11	2.89	3.59	2.61	1.53	74	44.51	60.17	44.52	11.33	137	44.91	65.56	20.80	11.70
12	2.91	3.61	2.63	1.56	75	45.12	65.55	20.79	12.47	138	43.55	63.58	19.50	11.54
13	2.89	3.58	2.65	1.53	76	44.68	65.05	20.92	12.15	139	46.40	68.73	18.56	11.16
14	2.97	3.66	2.69	1.61	77	45.92	67.37	19.32	12.02	140	44.40	64.78	20.81	11.59
15	2.91	3.61	2.64	1.55	78	48.32	71.74	17.55	11.96	141	43.56	63.59	20.50	11.28
16	2.93	3.63	2.68	1.56	79	44.14	64.02	19.44	12.79	142	44.60	66.05	18.33	10.65
17	2.87	3.57	2.61	1.51	80	48.83	72.70	18.58	11.70	143	43.14	62.44	20.98	11.94
18	2.89	3.59	2.62	1.53	81	41.51	59.61	20.80	12.16	144	42.54	62.02	19.75	11.19
19	2.91	3.61	2.63	1.55	82	45.17	66.22	19.37	11.83	145	43.08	61.87	21.54	12.59
20	2.90	3.59	2.64	1.54	83	48.31	71.17	19.88	12.08	146	42.22	61.12	20.77	11.63
21	2.91	3.60	2.66	1.58	84	44.47	60.12	45.03	11.07	147	42.16	57.07	38.76	11.83
22	2.89	3.59	2.60	1.53	85	42.83	61.41	22.78	12.28	148	45.10	66.17	19.18	11.71
23	2.92	3.61	2.64	1.58	86	43.48	60.17	36.28	11.24	149	42.09	60.63	21.33	11.87
24	2.94	3.65	2.69	1.57	87	42.91	62.87	18.42	11.27	150	43.16	63.03	19.28	11.41
25	2.92	3.61	2.64	1.58	88	41.97	60.29	21.17	12.19	151	42.30	61.57	19.40	11.32
26	2.91	3.61	2.61	1.55	89	42.23	60.88	20.74	12.22	152	41.27	58.84	20.90	12.88
27	2.90	3.59	2.64	1.54	90	41.21	59.79	19.37	11.28	153	46.26	67.90	19.28	12.00
28	2.91	3.60	2.65	1.54	91	42.79	60.97	22.06	13.03	154	40.54	57.92	20.35	12.56
29	2.93	3.64	2.64	1.57	92	43.52	63.17	19.03	12.53	155	40.05	57.06	21.04	12.43
30	3.07	3.77	2.79	1.71	93	42.11	60.21	20.81	13.23	156	44.81	66.26	17.63	11.15
31	3.01	3.71	2.72	1.65	94	41.53	60.01	19.63	11.77	157	40.01	57.14	20.83	12.06
32	3.36	4.05	3.09	2.02	95	40.79	58.47	19.85	12.32	158	40.25	57.95	20.30	11.49
33	2.91	3.61	2.62	1.55	96	41.85	60.48	19.49	12.12	159	43.31	63.71	17.88	11.11
34	2.89	3.59	2.62	1.54	97	42.36	60.66	22.80	12.22	160	41.47	60.25	18.57	11.71
35	2.90	3.59	2.63	1.56	98	39.55	56.24	21.89	11.93	161	41.17	59.76	18.97	11.46
36	2.91	3.61	2.63	1.53	99	41.08	53.44	45.48	12.94	162	48.59	72.62	18.15	10.89
37	2.91	3.61	2.63	1.53	100	40.02	56.35	23.22	12.86	163	39.12	56.18	19.15	11.77
38	2.98	3.68	2.69	1.63	101	38.99	54.62	22.75	12.87	164	40.48	57.49	21.41	12.88
39	2.92	3.61	2.65	1.58	102	41.45	60.14	19.36	11.58	165	39.50	56.09	21.06	12.35
40	2.94	3.63	2.67	1.58	103	40.43	57.72	19.86	12.77	166	39.77	56.70	20.37	12.23
41	2.89	3.60	2.61	1.52	104	40.81	58.48	21.28	11.89	167	40.76	58.32	21.31	12.00
42	2.96	3.65	2.70	1.62	105	39.21	54.89	23.42	12.72	168	37.13	52.19	22.36	11.61
43	2.90	3.59	2.64	1.53	106	42.67	61.44	20.44	12.63	169	39.85	56.15	22.84	12.77
44	2.96	3.65	2.69	1.60	107	41.38	59.96	19.95	11.32	170	37.19	52.20	20.98	12.35
45	2.95	3.64	2.68	1.59	108	37.38	52.54	21.39	12.27	171	37.89	52.89	23.03	12.66
46	2.95	3.64	2.69	1.59	109	38.93	55.65	19.60	12.16	172	38.24	54.46	19.71	11.98
47	2.89	3.59	2.60	1.53	110	38.52	54.52	20.32	12.56	173	38.79	55.31	19.52	12.17
48	2.95	3.65	2.65	1.60	111	37.01	51.33	22.85	12.63	174	37.82	53.06	22.02	12.31
49	2.91	3.61	2.62	1.56	112	37.13	51.89	20.69	12.92	175	37.20	51.54	22.16	13.32
50	2.91	3.61	2.66	1.54	113	40.94	58.91	18.62	12.58	176	36.93	51.10	23.91	12.53
51	3.51	4.23	3.10	2.17	114	37.12	52.08	20.41	12.81	177	38.58	49.36	44.96	12.79
52	2.89	3.60	2.60	1.53	115	39.57	56.57	20.06	12.08	178	36.58	49.47	26.43	13.82
53	2.90	3.60	2.62	1.54	116	38.74	50.60	41.32	12.37	179	37.33	51.66	22.57	13.20
54	2.91	3.61	2.65	1.56	117	38.30	53.73	23.08	12.35	180	16.04	18.65	13.46	11.65
55	2.92	3.61	2.63	1.57	118	38.16	54.90	19.06	10.94	181	14.84	15.73	13.11	13.72
56	2.94	3.64	2.66	1.57	119	14.58	15.83	12.41	12.85	182	7.43	8.37	6.99	5.64
57	2.90	3.59	2.66	1.54	120	21.52	8.96	7.40	54.31	Average	28.72	40.29	17.43	9.14
58	2.89	3.58	2.60	1.54	121	25.45	7.38	59.47	48.84					
59	2.89	3.59	2.63	1.52	122	29.16	6.73	166.66	16.23					
60	2.89	3.58	2.60	1.53	123	27.03	7.01	144.43	18.10					
61	2.92	3.62	2.63	1.56	124	35.59	39.15	64.92	15.25					
62	7.28	3.65	2.71	16.95	125	54.00	81.89	17.26	10.61					

### Sustainability – Average Response Time (ms) Distribution Graph

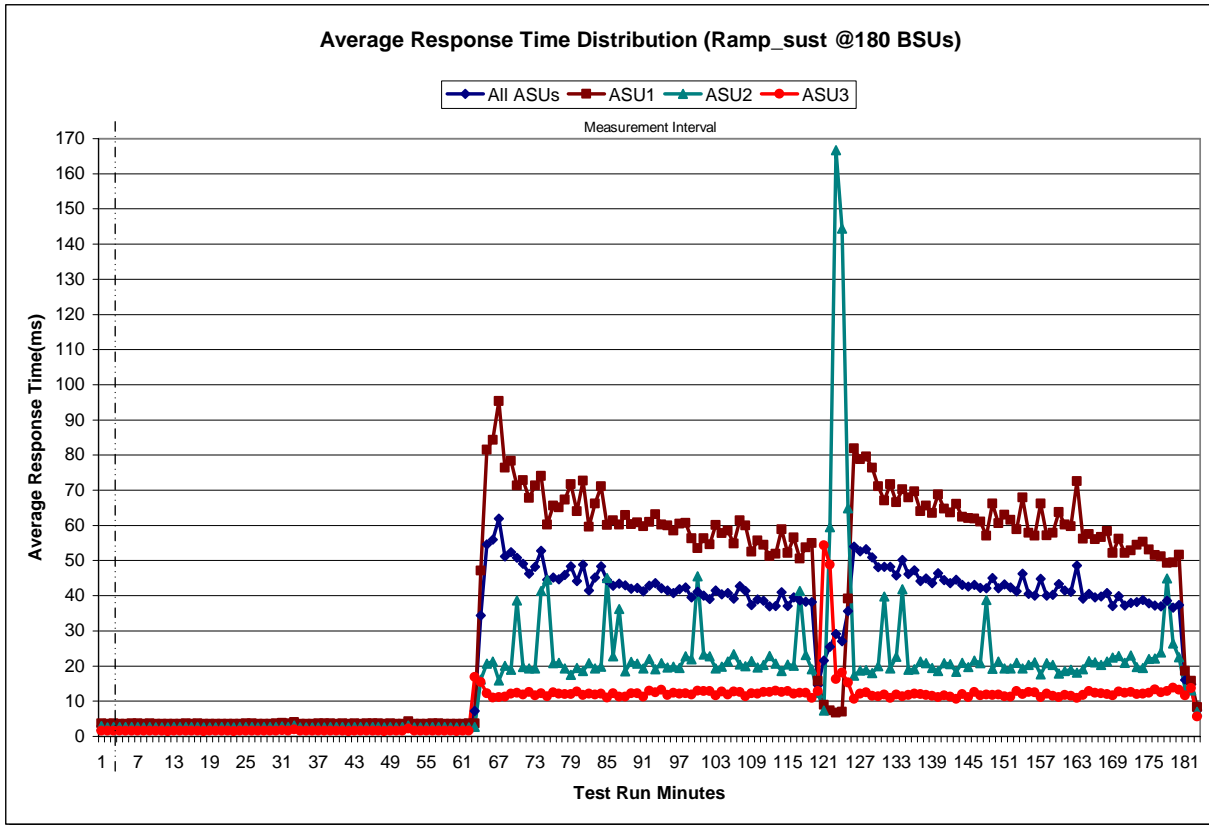

**Sustainability – Response Time Frequency Distribution Data**

Response Time (ms)	0-0.25	>0.25-0.5	>0.5-0.75	>0.75-1.0	>1.0-1.25	>1.25-1.5	>1.5-1.75	>1.75-2.0
Read	214,243	3,656,498	1,797,847	997,139	614,614	370,477	225,261	162,866
Write	-	21,873	1,871,335	8,028,891	7,811,106	3,450,630	1,559,284	1,161,498
All ASUs	214,243	3,678,371	3,669,182	9,026,030	8,425,720	3,821,107	1,784,545	1,324,364
ASU1	151,423	2,521,220	2,153,044	4,388,659	3,590,665	1,438,394	655,350	488,581
ASU2	62,820	1,150,759	842,687	1,241,457	992,610	424,730	201,314	139,124
ASU3	-	6,392	673,451	3,395,914	3,842,445	1,957,983	927,881	696,659
Response Time (ms)	>2.0-2.5	>2.5-3.0	>3.0-3.5	>3.5-4.0	>4.0-4.5	>4.5-5.0	>5.0-6.0	>6.0-7.0
Read	362,607	458,754	601,018	696,832	944,910	1,276,395	3,300,262	3,202,595
Write	2,001,222	1,754,005	1,582,792	1,420,631	1,255,279	1,087,204	1,722,435	1,268,314
All ASUs	2,363,829	2,212,759	2,183,810	2,117,463	2,200,189	2,363,599	5,022,697	4,470,909
ASU1	921,270	924,714	998,056	1,037,042	1,226,709	1,486,204	3,504,194	3,208,361
ASU2	214,036	181,765	173,336	164,796	167,252	185,032	440,805	482,928
ASU3	1,228,523	1,106,280	1,012,418	915,625	806,228	692,363	1,077,698	779,620
Response Time (ms)	>7.0-8.0	>8.0-9.0	>9.0-10.0	>10.0-15.0	>15.0-20.0	>20.0-25.0	>25.0-30.0	>30.0
Read	3,193,178	2,314,344	1,577,021	3,858,867	1,604,194	894,800	596,479	5,377,723
Write	1,013,160	887,862	838,345	3,581,927	2,684,366	2,080,702	1,533,758	10,204,385
All ASUs	4,206,338	3,202,206	2,415,366	7,440,794	4,288,560	2,975,502	2,130,237	15,582,108
ASU1	3,084,546	2,234,853	1,593,452	4,646,292	2,439,765	1,611,697	1,172,391	12,404,956
ASU2	512,698	452,912	353,890	950,825	562,791	415,473	304,786	1,321,740
ASU3	609,094	514,441	468,024	1,843,677	1,286,004	948,332	653,060	1,855,412

**Sustainability – Response Time Frequency Distribution Graph**

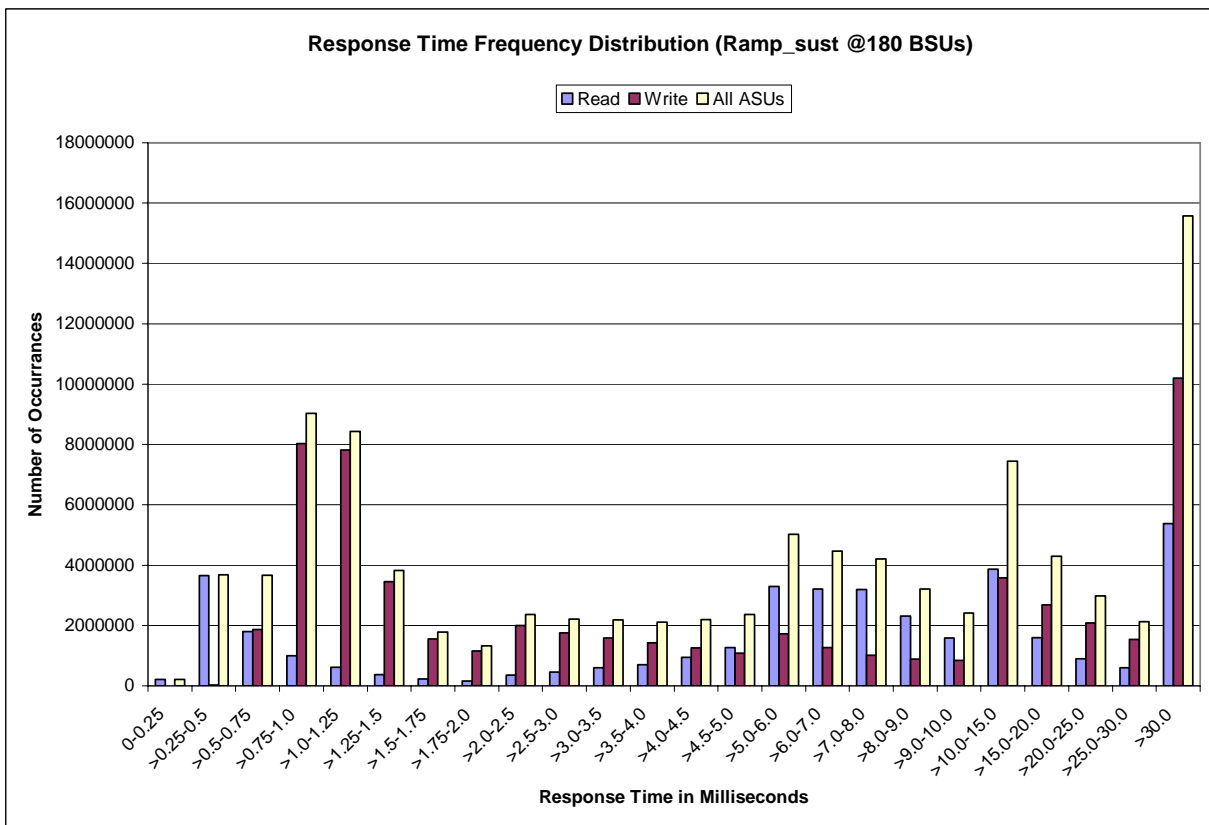

**Sustainability – Measured Intensity Multiplier and Coefficient of Variation**

Clause 3.4.3

**IM – Intensity Multiplier:** *The ratio of I/Os for each I/O stream relative to the total I/Os for all I/O streams (ASU1-1 – ASU3-1) as required by the benchmark specification.*

Clauses 5.1.0 and 5.3.13.2

**MIM – Measured Intensity Multiplier:** *The Measured Intensity Multiplier represents the ratio of measured I/Os for each I/O stream relative to the total I/Os measured for all I/O streams (ASU1-1 – ASU3-1). This value may differ from the corresponding Expected Intensity Multiplier by no more than 5%.*

Clause 5.3.13.3

**COV – Coefficient of Variation:** *This measure of variation for the Measured Intensity Multiplier cannot exceed 0.2.*

	ASU1-1	ASU1-2	ASU1-3	ASU1-4	ASU2-1	ASU2-2	ASU2-3	ASU3-1
IM	0.0350	0.2810	0.0700	0.2100	0.0180	0.0700	0.0350	0.2810
MIM	0.0350	0.2810	0.0700	0.2100	0.0180	0.0700	0.0350	0.2811
COV	0.007	0.002	0.006	0.003	0.010	0.005	0.008	0.002

## Primary Metrics Test – IOPS Test Phase

### Clause 5.4.2.2

*The IOPS Test Phase consists of one Test Run at the 100% load point with a Measurement Interval of ten (10) minutes. The IOPS Test Phase immediately follows the Sustainability Test Phase without any interruption or manual intervention.*

*The IOPS Test Run generates the SPC-1 IOPS™ primary metric, which is computed as the I/O Request Throughput for the Measurement Interval of the IOPS Test Run.*

*The Average Response Time is computed for the IOPS Test Run and cannot exceed 30 milliseconds. If the Average Response Time exceeds the 30 millisecond constraint, the measurement is invalid.*

### Clause 9.2.4.7.2

*For the IOPS Test Phase the FDR shall contain:*

- 1. I/O Request Throughput Distribution (data and graph).*
- 2. A Response Time Frequency Distribution.*
- 3. An Average Response Time Distribution.*
- 4. The human readable Test Run Results File produced by the Workload Generator.*
- 5. A listing or screen image of all input parameters supplied to the Workload Generator.*
- 6. The total number of I/O Requests completed in the Measurement Interval as well as the number of I/O Requests with a Response Time less than or equal to 30 milliseconds and the number of I/O Requests with a Response Time greater than 30 milliseconds.*

## SPC-1 Workload Generator Input Parameters

The SPC-1 Workload Generator input parameters for the Sustainability, IOPS, Response Time Ramp, Repeatability, and Persistence Test Runs are documented in “Appendix E: SPC-1 Workload Generator Input Parameters” on Page 67.

## IOPS Test Results File

A link to the test results file generated from the IOPS Test Run is listed below.

[IOPS Test Results File](#)

**IOPS Test Run – I/O Request Throughput Distribution Data**

180 BSUs	Start	Stop	Interval	Duration
Start-Up/Ramp-Up	18:26:52	18:29:53	0-2	0:03:01
Measurement Interval	18:29:53	18:39:53	3-12	0:10:00
60 second intervals	All ASUs	ASU1	ASU2	ASU3
0	9,010.77	5,359.12	1,112.82	2,538.83
1	9,003.57	5,366.90	1,107.37	2,529.30
2	8,987.03	5,360.97	1,106.52	2,519.55
3	8,993.60	5,364.55	1,109.80	2,519.25
4	8,981.88	5,357.87	1,101.98	2,522.03
5	9,000.70	5,364.68	1,108.68	2,527.33
6	9,005.88	5,361.13	1,110.07	2,534.68
7	8,992.23	5,364.10	1,102.82	2,525.32
8	9,005.55	5,369.05	1,106.37	2,530.13
9	8,994.60	5,373.38	1,103.50	2,517.72
10	8,993.18	5,361.08	1,107.90	2,524.20
11	8,994.95	5,355.90	1,105.55	2,533.50
12	9,009.12	5,366.78	1,109.18	2,533.15
Average	8,997.17	5,363.85	1,106.59	2,526.73

**IOPS Test Run – I/O Request Throughput Distribution Graph**

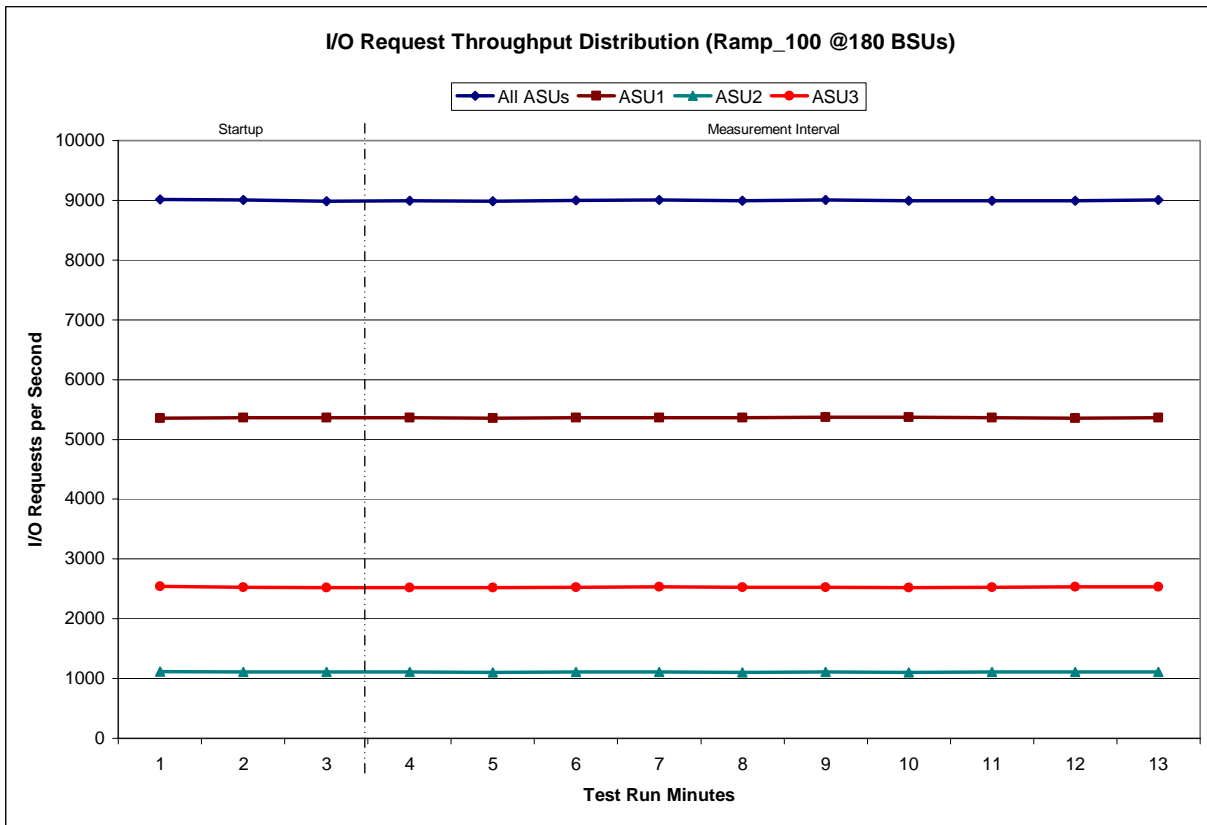

**IOPS Test Run – Average Response Time (ms) Distribution Data**

180 BSUs	Start	Stop	Interval	Duration
<i>Start-Up/Ramp-Up</i>	18:26:52	18:29:53	0-2	0:03:01
<i>Measurement Interval</i>	18:29:53	18:39:53	3-12	0:10:00
60 second intervals	All ASUs	ASU1	ASU2	ASU3
0	3.09	3.78	3.07	1.62
1	2.95	3.65	2.64	1.61
2	2.90	3.59	2.63	1.54
3	2.92	3.62	2.62	1.57
4	2.87	3.56	2.61	1.52
5	2.91	3.60	2.63	1.55
6	2.90	3.60	2.64	1.55
7	2.92	3.61	2.65	1.56
8	2.91	3.60	2.64	1.56
9	2.90	3.59	2.63	1.55
10	2.89	3.58	2.63	1.52
11	2.94	3.64	2.70	1.58
12	3.02	3.71	2.76	1.67
<b>Average</b>	2.92	3.61	2.65	1.56

**IOPS Test Run – Average Response Time (ms) Distribution Graph**

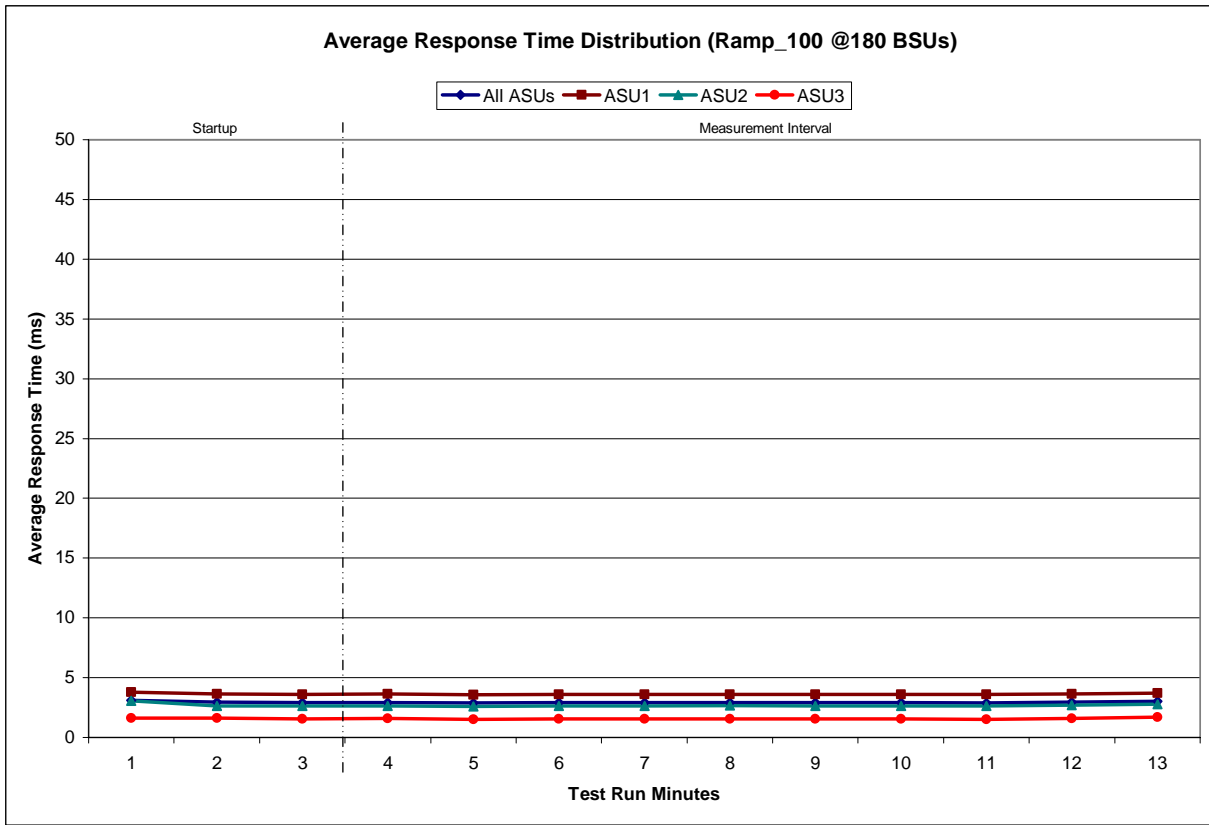

**IOPS Test Run – Response Time Frequency Distribution Data**

Response Time (ms)	0-0.25	>0.25-0.5	>0.5-0.75	>0.75-1.0	>1.0-1.25	>1.25-1.5	>1.5-1.75	>1.75-2.0
Read	29457	444,387	81,742	5,632	2,098	2,487	2,828	5,966
Write	0	4,086	290,576	1,238,128	1,144,701	382,016	68,332	12,569
All ASUs	29457	448,473	372,318	1,243,760	1,146,799	384,503	71,160	18,535
ASU1	21057	313,488	211,447	593,553	479,592	136,386	23,763	10,046
ASU2	8400	133,841	59,430	138,103	114,136	32,621	5,242	1,273
ASU3	0	1,144	101,441	512,104	553,071	215,496	42,155	7,216
Response Time (ms)	>2.0-2.5	>2.5-3.0	>3.0-3.5	>3.5-4.0	>4.0-4.5	>4.5-5.0	>5.0-6.0	>6.0-7.0
Read	30,615	43,255	57,661	63,530	87,944	119,683	290,583	225,655
Write	7,389	5,473	4,856	3,941	3,464	3,807	8,131	9,170
All ASUs	38,004	48,728	62,517	67,471	91,408	123,490	298,714	234,825
ASU1	32,467	43,839	57,038	62,218	84,436	113,346	268,307	201,471
ASU2	1,879	2,363	3,197	3,357	5,255	8,285	26,001	27,783
ASU3	3,658	2,526	2,282	1,896	1,717	1,859	4,406	5,571
Response Time (ms)	>7.0-8.0	>8.0-9.0	>9.0-10.0	>10.0-15.0	>15.0-20.0	>20.0-25.0	>25.0-30.0	>30.0
Read	225,630	119,843	69,796	161,554	41,213	11,197	4,052	2,973
Write	11,264	12,174	12,317	30,918	7,935	3,446	1,775	2,017
All ASUs	236,894	132,017	82,113	192,472	49,148	14,643	5,827	4,990
ASU1	199,357	102,765	61,246	149,283	36,687	9,947	3,694	2,853
ASU2	30,001	20,894	12,078	21,126	5,520	1,747	732	683
ASU3	7,536	8,358	8,789	22,063	6,941	2,949	1,401	1,454

**IOPS Test Run –Response Time Frequency Distribution Graph**

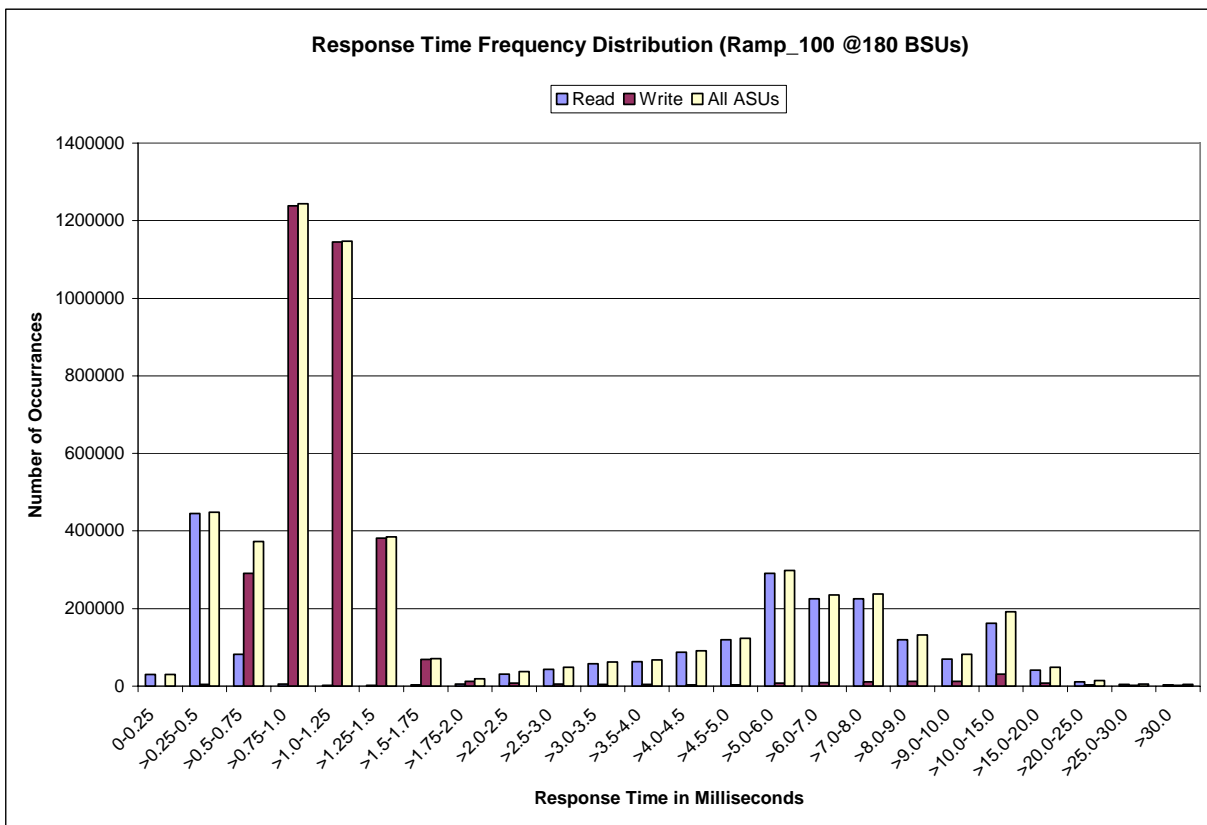

### IOPS Test Run – I/O Request Information

I/O Requests Completed in the Measurement Interval	I/O Requests Completed with Response Time = or < 30 ms	I/O Requests Completed with Response Time > 30 ms
5,398,266	5,393,276	4,990

### IOPS Test Run – Measured Intensity Multiplier and Coefficient of Variation

Clause 3.4.3

**IM – Intensity Multiplier:** The ratio of I/Os for each I/O stream relative to the total I/Os for all I/O streams (ASU1-1 – ASU3-1) as required by the benchmark specification.

Clauses 5.1.0 and 5.3.13.2

**MIM – Measured Intensity Multiplier:** The Measured Intensity Multiplier represents the ratio of measured I/Os for each I/O stream relative to the total I/Os measured for all I/O streams (ASU1-1 – ASU3-1). This value may differ from the corresponding Expected Intensity Multiplier by no more than 5%.

Clause 5.3.13.3

**COV – Coefficient of Variation:** This measure of variation for the Measured Intensity Multiplier cannot exceed 0.2.

	ASU1-1	ASU1-2	ASU1-3	ASU1-4	ASU2-1	ASU2-2	ASU2-3	ASU3-1
<b>IM</b>	0.0350	0.2810	0.0700	0.2100	0.0180	0.0700	0.0350	0.2810
MIM	0.0350	0.2810	0.2101	0.0179	0.0700	0.0700	0.0350	0.2808
COV	0.004	0.003	0.004	0.,002	0.007	0.003	0.005	0.002

## Primary Metrics Test – Response Time Ramp Test Phase

### Clause 5.4.2.3

*The Response Time Ramp Test Phase consists of five Test Runs, one each at 95%, 90%, 80%, 50%, and 10% of the load point (100%) used to generate the SPC-1 IOPS™ primary metric. Each of the five Test Runs has a Measurement Interval of ten (10) minutes. The Response Time Ramp Test Phase immediately follows the IOPS Test Phase without any interruption or manual intervention.*

*The five Response Time Ramp Test Runs, in conjunction with the IOPS Test Run (100%), demonstrate the relationship between Average Response Time and I/O Request Throughput for the Tested Storage Configuration (TSC) as illustrated in the response time/throughput curve on page 12.*

*In addition, the Average Response Time measured during the 10% Test Run is the value for the SPC-1 LRT™ metric. That value represents the Average Response Time of a lightly loaded TSC.*

### Clause 9.2.4.7.3

*The following content shall appear in the FDR for the Response Time Ramp Phase:*

- 1. A Response Time Ramp Distribution.*
- 2. The human readable Test Run Results File produced by the Workload Generator for each Test Run within the Response Time Ramp Test Phase.*
- 3. For the 10% Load Level Test Run (SPC-1 LRT™ metric) an Average Response Time Distribution.*
- 4. A listing or screen image of all input parameters supplied to the Workload Generator.*

## SPC-1 Workload Generator Input Parameters

The SPC-1 Workload Generator input parameters for the Sustainability, IOPS, Response Time Ramp, Repeatability, and Persistence Test Runs are documented in “Appendix E: SPC-1 Workload Generator Input Parameters” on Page 67.

## Response Time Ramp Test Results File

A link to each test result file generated from each Response Time Ramp Test Run list listed below.

[95% Load Level](#)

[90% Load Level](#)

[80% Load Level](#)

[50% Load Level](#)

[10% Load Level](#)

**Response Time Ramp Distribution (IOPS) Data**

The five Test Runs that comprise the Response Time Ramp Phase are executed at 95%, 90%, 80%, 50%, and 10% of the Business Scaling Unit (BSU) load level used to produce the SPC-1 IOPS™ primary metric. The 100% BSU load level is included in the following Response Time Ramp data tables and graphs for completeness.

100% Load Level - 180 BSUs					171 BSUs				
Start	Stop	Interval	Duration		Start	Stop	Interval	Duration	
18:26:52	18:29:53	0-2	0:03:01		18:39:55	18:42:56	0-2	0:03:01	
18:29:53	18:39:53	3-12	0:10:00		18:42:56	18:52:56	3-12	0:10:00	
<i>(60 second intervals)</i>					<i>(60 second intervals)</i>				
All ASUs	ASU-1	ASU-2	ASU-3		All ASUs	ASU-1	ASU-2	ASU-3	
0	9,010.77	5,359.12	1,112.82	2,538.83	0	8,558.25	5,095.67	1,054.53	2,408.05
1	9,003.57	5,366.90	1,107.37	2,529.30	1	8,567.45	5,108.10	1,051.68	2,407.67
2	8,987.03	5,360.97	1,106.52	2,519.55	2	8,542.40	5,090.05	1,044.23	2,408.12
3	8,993.60	5,364.55	1,109.80	2,519.25	3	8,551.82	5,095.20	1,050.05	2,406.57
4	8,981.88	5,357.87	1,101.98	2,522.03	4	8,548.17	5,096.95	1,052.65	2,398.57
5	9,000.70	5,364.68	1,108.68	2,527.33	5	8,554.50	5,106.10	1,052.63	2,395.77
6	9,005.88	5,361.13	1,110.07	2,534.68	6	8,545.58	5,093.93	1,050.40	2,401.25
7	8,992.23	5,364.10	1,102.82	2,525.32	7	8,522.32	5,089.02	1,042.78	2,390.52
8	9,005.55	5,369.05	1,106.37	2,530.13	8	8,542.43	5,102.05	1,053.82	2,386.57
9	8,994.60	5,373.38	1,103.50	2,517.72	9	8,558.23	5,101.75	1,042.55	2,413.93
10	8,993.18	5,361.08	1,107.90	2,524.20	10	8,534.30	5,085.05	1,057.57	2,391.68
11	8,994.95	5,355.90	1,105.55	2,533.50	11	8,549.25	5,087.57	1,056.62	2,405.07
12	9,009.12	5,366.78	1,109.18	2,533.15	12	8,551.37	5,096.38	1,051.10	2,403.88
Average	8,997.17	5,363.85	1,106.59	2,526.73	Average	8,545.80	5,095.40	1,051.02	2,399.38
90% Load Level - 162 BSUs					80% Load Level - 144 BSUs				
Start	Stop	Interval	Duration		Start	Stop	Interval	Duration	
18:52:58	18:55:59	0-2	0:03:01		19:06:00	19:09:01	0-2	0:03:01	
18:55:59	19:05:59	3-12	0:10:00		19:09:01	19:19:01	3-12	0:10:00	
<i>(60 second intervals)</i>					<i>(60 second intervals)</i>				
All ASUs	ASU-1	ASU-2	ASU-3		All ASUs	ASU-1	ASU-2	ASU-3	
0	8,082.90	4,811.60	1,000.05	2,271.25	0	7,211.03	4,299.43	884.23	2,027.37
1	8,084.57	4,812.18	992.53	2,279.85	1	7,201.50	4,294.90	886.32	2,020.28
2	8,100.87	4,827.93	992.37	2,280.57	2	7,220.07	4,302.17	887.08	2,030.82
3	8,089.40	4,822.73	993.80	2,272.87	3	7,219.07	4,299.03	888.13	2,031.90
4	8,106.75	4,835.53	993.25	2,277.97	4	7,192.15	4,279.03	891.95	2,021.17
5	8,111.55	4,825.60	999.52	2,286.43	5	7,196.10	4,296.90	881.55	2,017.65
6	8,104.87	4,836.32	999.98	2,268.57	6	7,199.15	4,290.03	885.92	2,023.20
7	8,079.03	4,806.52	1,001.85	2,270.67	7	7,185.20	4,270.60	887.47	2,027.13
8	8,111.12	4,837.05	989.60	2,284.47	8	7,194.77	4,286.70	888.08	2,019.98
9	8,094.33	4,819.32	998.98	2,276.03	9	7,209.12	4,298.25	885.33	2,025.53
10	8,092.47	4,809.55	998.40	2,284.52	10	7,212.40	4,296.03	885.70	2,030.67
11	8,103.58	4,829.58	994.70	2,279.30	11	7,206.05	4,288.52	886.43	2,031.10
12	8,111.87	4,838.30	995.60	2,277.97	12	7,195.35	4,283.32	886.55	2,025.48
Average	8,100.50	4,826.05	996.57	2,277.88	Average	7,200.94	4,288.84	886.71	2,025.38
50% Load Level - 90 BSUs					10% Load Level - 18 BSUs				
Start	Stop	Interval	Duration		Start	Stop	Interval	Duration	
19:19:03	19:22:04	0-2	0:03:01		19:32:05	19:35:06	0-2	0:03:01	
19:22:04	19:32:04	3-12	0:10:00		19:35:06	19:45:06	3-12	0:10:00	
<i>(60 second intervals)</i>					<i>(60 second intervals)</i>				
All ASUs	ASU-1	ASU-2	ASU-3		All ASUs	ASU-1	ASU-2	ASU-3	
0	4,505.67	2,673.92	560.52	1,271.23	0	901.82	539.08	108.97	253.77
1	4,500.95	2,679.53	551.48	1,269.93	1	900.65	538.22	111.07	251.37
2	4,492.72	2,673.75	558.93	1,260.03	2	903.07	537.17	111.28	254.62
3	4,493.98	2,682.40	554.08	1,257.50	3	893.62	535.12	109.38	249.12
4	4,506.48	2,686.22	555.17	1,265.10	4	903.47	537.88	112.00	253.58
5	4,504.12	2,682.85	552.68	1,268.58	5	900.85	537.27	111.77	251.82
6	4,491.48	2,677.90	549.80	1,263.78	6	900.55	535.12	111.07	254.37
7	4,500.98	2,685.17	553.48	1,262.33	7	897.52	536.57	109.50	251.45
8	4,505.57	2,683.15	553.58	1,268.83	8	890.58	529.15	111.05	250.38
9	4,493.72	2,680.95	553.47	1,259.30	9	904.18	537.73	110.82	255.63
10	4,497.45	2,678.95	552.87	1,265.63	10	901.37	536.67	110.75	253.95
11	4,501.57	2,689.42	550.08	1,262.07	11	898.83	536.52	110.68	251.63
12	4,498.15	2,686.73	549.00	1,262.42	12	896.50	532.92	109.50	254.08
Average	4,499.35	2,683.37	552.42	1,263.56	Average	898.75	535.49	110.65	252.60

### Response Time Ramp Distribution (IOPS) Graph

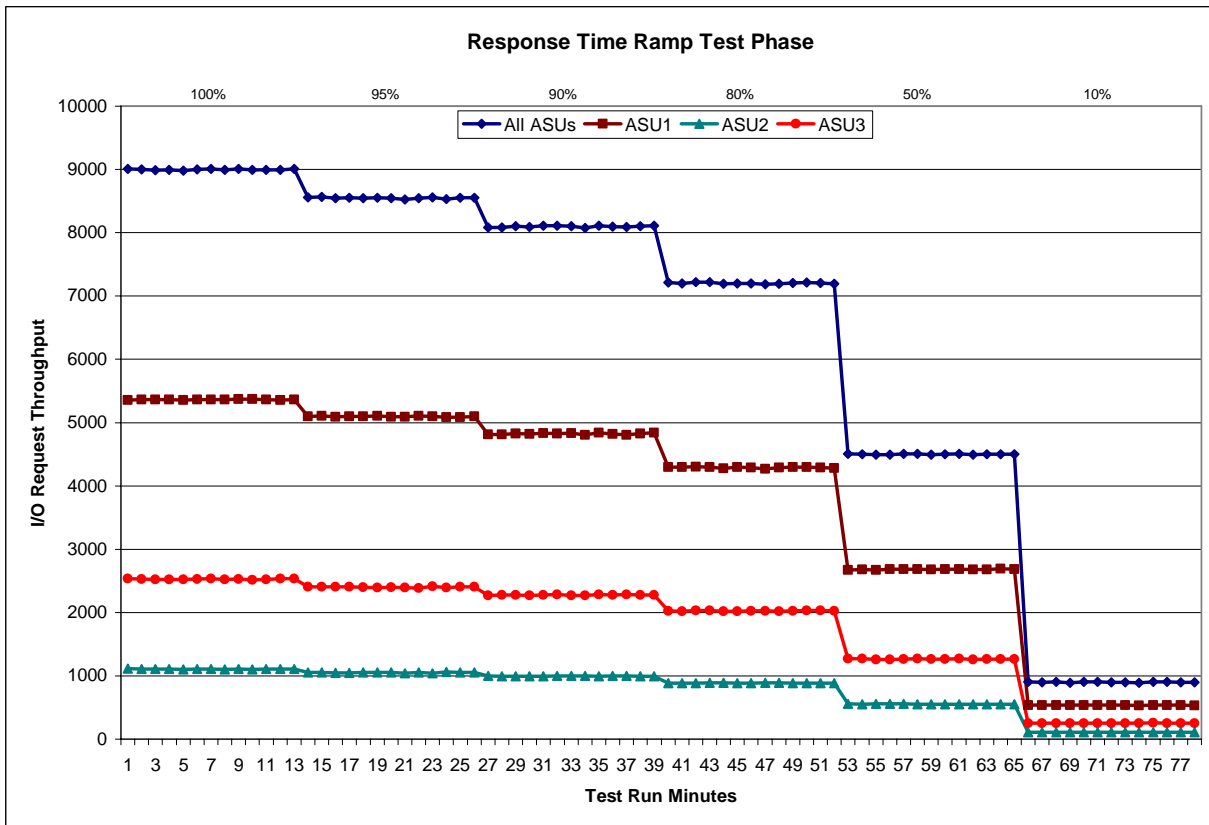

**SPC-1 LRT™ Average Response Time (ms) Distribution Data**

18 BSUs	Start	Stop	Interval	Duration
<b>Start-Up/Ramp-Up</b>	19:32:05	19:35:06	0-2	0:03:01
<b>Measurement Interval</b>	19:35:06	19:45:06	3-12	0:10:00
<b>60 second intervals</b>	<b>All ASUs</b>	<b>ASU1</b>	<b>ASU2</b>	<b>ASU3</b>
0	2.04	2.66	2.11	0.70
1	1.85	2.47	1.57	0.64
2	1.85	2.47	1.56	0.69
3	1.87	2.48	1.60	0.68
4	1.85	2.47	1.51	0.68
5	1.85	2.45	1.60	0.66
6	1.84	2.47	1.54	0.67
7	1.85	2.48	1.54	0.66
8	1.85	2.47	1.56	0.67
9	1.85	2.47	1.53	0.68
10	1.88	2.49	1.66	0.68
11	1.86	2.48	1.57	0.67
12	1.87	2.50	1.63	0.67
<b>Average</b>	1.86	2.47	1.58	0.67

**SPC-1 LRT™ Average Response Time (ms) Distribution Graph**

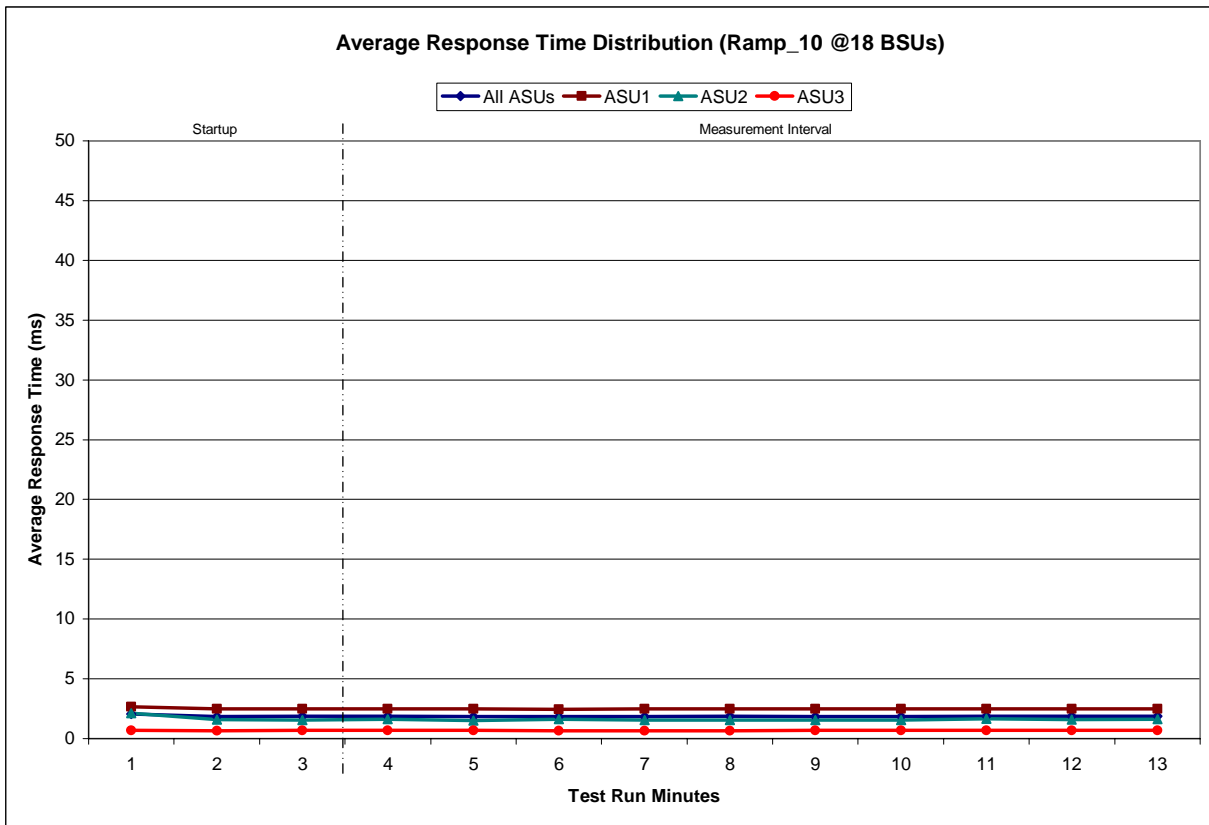

**SPC-1 LRT™ (10%) – Measured Intensity Multiplier and Coefficient of Variation**

Clause 3.4.3

**IM – Intensity Multiplier:** The ratio of I/Os for each I/O stream relative to the total I/Os for all I/O streams (ASU1-1 – ASU3-1) as required by the benchmark specification.

Clauses 5.1.0 and 5.3.13.2

**MIM – Measured Intensity Multiplier:** The Measured Intensity Multiplier represents the ratio of measured I/Os for each I/O stream relative to the total I/Os measured for all I/O streams (ASU1-1 – ASU3-1). This value may differ from the corresponding Expected Intensity Multiplier by no more than 5%.

Clause 5.3.13.3

**COV – Coefficient of Variation:** This measure of variation for the Measured Intensity Multiplier cannot exceed 0.2.

	ASU1-1	ASU1-2	ASU1-3	ASU1-4	ASU2-1	ASU2-2	ASU2-3	ASU3-1
IM	0.0350	0.2810	0.0700	0.2100	0.0180	0.0700	0.0350	0.2810
MIM	0.0351	0.2810	0.0702	0.2095	0.0177	0.0701	0.0354	0.2811
COV	0.024	0.006	0.012	0.008	0.040	0.004	0.016	0.005

## Repeatability Test

### Clause 5.4.5

*The Repeatability Test demonstrates the repeatability and reproducibility of the SPC-1 IOPS™ primary metric and SPC-1 LRT™ metric generated in earlier Test Runs.*

*There are two identical Repeatability Test Phases. Each Test Phase contains two Test Runs. Each of the Test Runs will have a Measurement Interval of no less than ten (10) minutes. The two Test Runs in each Test Phase will be executed without interruption or any type of manual intervention.*

*The first Test Run in each Test Phase is executed at the 10% load point. The Average Response Time from each of the Test Runs is compared to the SPC-1 LRT™ metric. Each Average Response Time value must be less than the SPC-1 LRT™ metric plus 5%.*

*The second Test Run in each Test Phase is executed at the 100% load point. The I/O Request Throughput from the Test Runs is compared to the SPC-1 IOPS™ primary metric. Each I/O Request Throughput value must be greater than the SPC-1 IOPS™ primary metric minus 5%. In addition, the Average Response Time for each Test Run cannot exceed 30 milliseconds.*

*If any of the above constraints are not met, the benchmark measurement is invalid.*

### Clause 9.2.4.7.4

*The following content shall appear in the FDR for each Test Run in the two Repeatability Test Phases:*

- 1. A table containing the results of the Repeatability Test.*
- 2. An I/O Request Throughput Distribution graph and table.*
- 3. An Average Response Time Distribution graph and table.*
- 4. The human readable Test Run Results File produced by the Workload Generator.*
- 5. A listing or screen image of all input parameters supplied to the Workload Generator.*

## SPC-1 Workload Generator Input Parameters

The SPC-1 Workload Generator input parameters for the Sustainability, IOPS, Response Time Ramp, Repeatability, and Persistence Test Runs are documented in “Appendix E: SPC-1 Workload Generator Input Parameters” on Page 67.

### Repeatability Test Results File

The values for the SPC-1 IOPS™, SPC-1 LRT™, and the Repeatability Test measurements are listed below.

	SPC-1 IOPS™	SPC-1 LRT™
<i>Primary Metrics</i>	<b>8,997.17</b>	<b>1.86</b>
Repeatability Test Phase 1	9,002.63	1.87
Repeatability Test Phase 2	9,004.25	1.86

A link to the test result file generated from each Repeatability Test Run list is listed below.

[Repeatability Test Phase 1, Test Run 1 \(LRT\)](#)

[Repeatability Test Phase 1, Test Run 2 \(IOPS\)](#)

[Repeatability Test Phase 2, Test Run 1 \(LRT\)](#)

[Repeatability Test Phase 2, Test Run 2 \(IOPS\)](#)

**Repeatability 1 LRT - I/O Request Throughput Distribution Data**

18 BSUs	Start	Stop	Interval	Duration
<i>Start-Up/Ramp-Up</i>	19:45:09	19:48:09	0-2	0:03:00
<i>Measurement Interval</i>	19:48:09	19:58:09	3-12	0:10:00
60 second intervals	All ASUs	ASU1	ASU2	ASU3
0	902.08	537.75	109.90	254.43
1	895.90	537.13	108.72	250.05
2	891.83	529.85	110.23	251.75
3	905.40	539.90	114.47	251.03
4	904.73	538.10	111.48	255.15
5	899.30	537.93	109.78	251.58
6	901.07	535.82	112.28	252.97
7	904.68	537.67	109.73	257.28
8	896.53	531.03	112.83	252.67
9	900.82	537.78	110.45	252.58
10	898.22	532.55	112.67	253.00
11	895.88	533.43	111.18	251.27
12	897.13	532.22	110.02	254.90
<b>Average</b>	900.38	535.64	111.49	253.24

**Repeatability 1 LRT - I/O Request Throughput Distribution Graph**

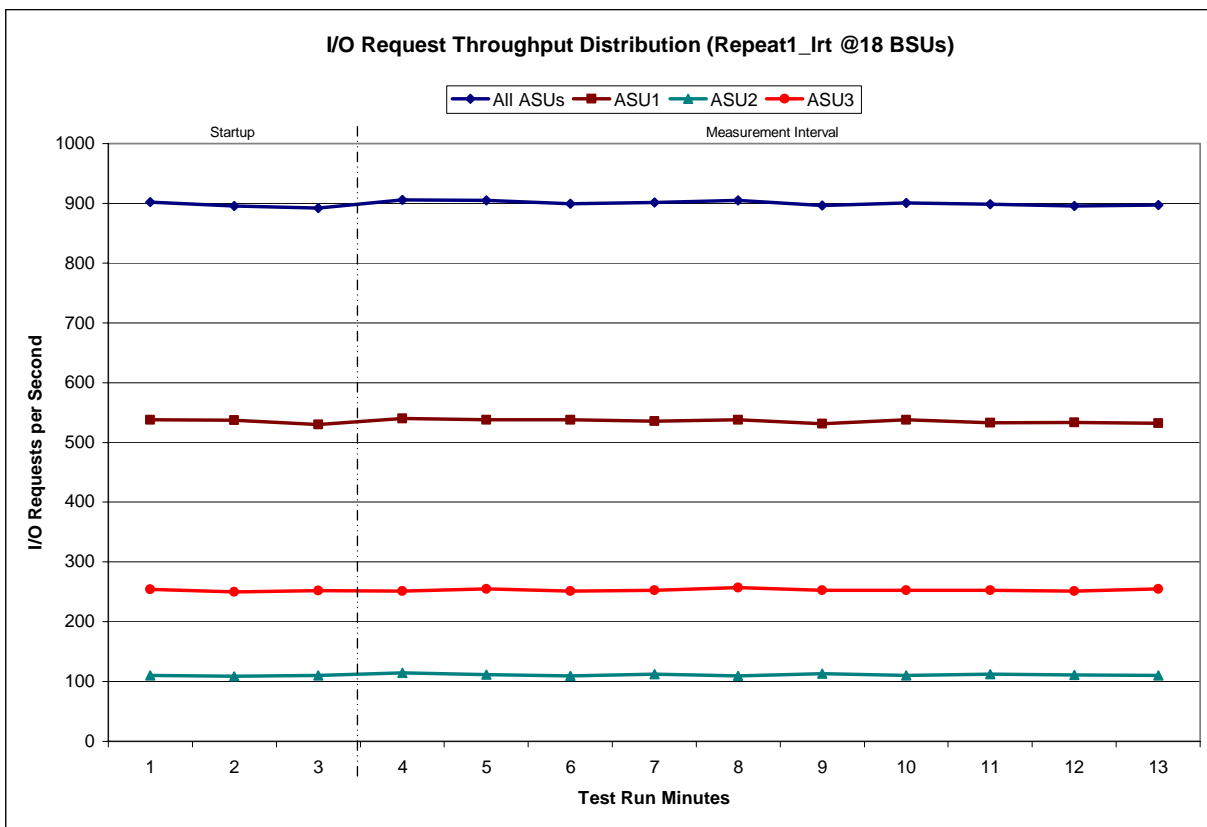

**Repeatability 1 LRT –Average Response Time (ms) Distribution Data**

18 BSUs	Start	Stop	Interval	Duration
<i>Start-Up/Ramp-Up</i>	19:45:09	19:48:09	0-2	0:03:00
<i>Measurement Interval</i>	19:48:09	19:58:09	3-12	0:10:00
60 second intervals	All ASUs	ASU1	ASU2	ASU3
0	1.97	2.58	1.96	0.68
1	1.85	2.45	1.56	0.66
2	1.84	2.46	1.55	0.68
3	1.86	2.48	1.55	0.67
4	1.84	2.45	1.55	0.67
5	1.84	2.45	1.55	0.66
6	1.88	2.49	1.64	0.68
7	1.87	2.50	1.56	0.68
8	1.88	2.54	1.52	0.67
9	1.89	2.51	1.63	0.69
10	1.86	2.48	1.61	0.68
11	1.87	2.49	1.61	0.69
12	1.91	2.53	1.68	0.72
<b>Average</b>	1.87	2.49	1.59	0.68

**Repeatability 1 LRT –Average Response Time (ms) Distribution Graph**

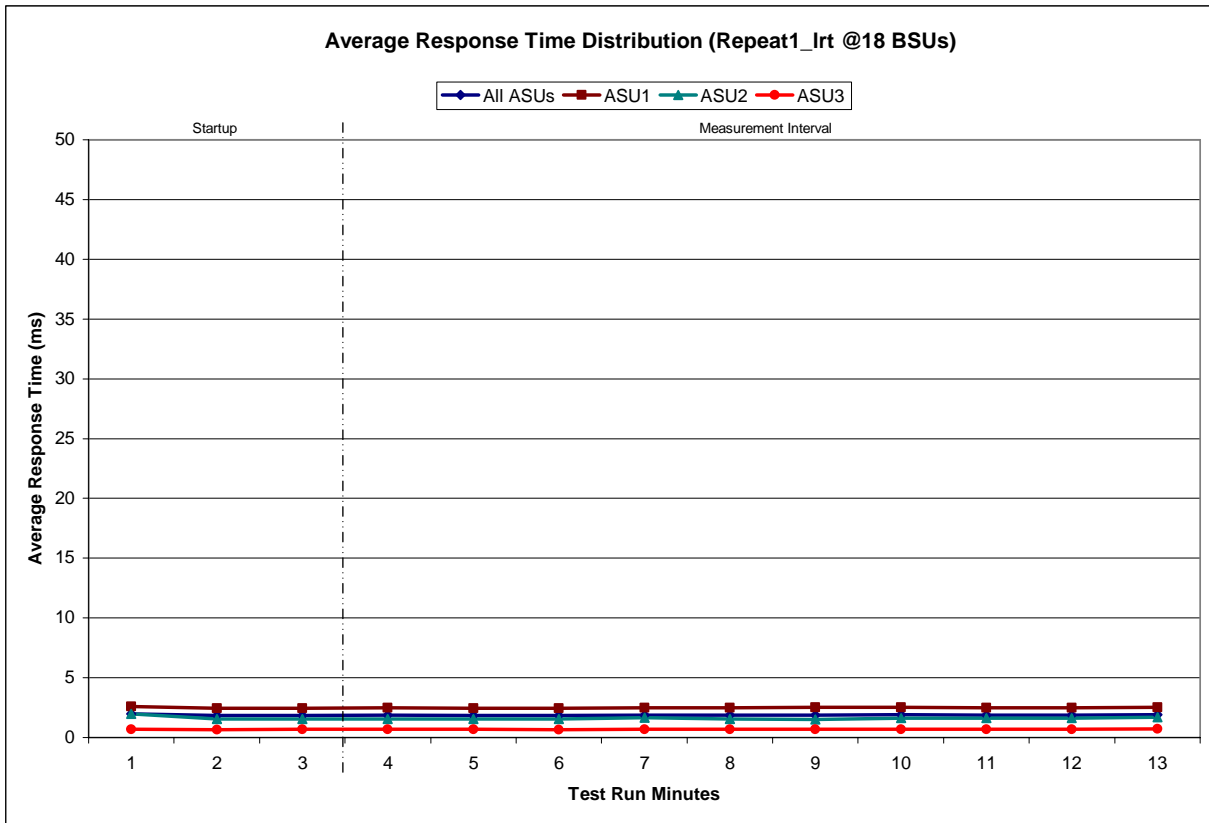

**Repeatability 1 IOPS - I/O Request Throughput Distribution Data**

180 BSUs	Start	Stop	Interval	Duration
Start-Up/Ramp-Up	19:58:11	20:01:12	0-2	0:03:01
Measurement Interval	20:01:12	20:11:12	3-12	0:10:00
60 second intervals	All ASUs	ASU1	ASU2	ASU3
0	8,996.50	5,363.93	1,102.88	2,529.68
1	8,980.83	5,358.37	1,099.57	2,522.90
2	9,007.38	5,381.35	1,111.12	2,514.92
3	9,039.75	5,389.72	1,103.33	2,546.70
4	8,994.00	5,353.32	1,108.72	2,531.97
5	9,001.83	5,368.88	1,101.23	2,531.72
6	9,021.85	5,368.90	1,110.90	2,542.05
7	8,992.85	5,366.20	1,109.58	2,517.07
8	9,017.63	5,374.50	1,110.35	2,532.78
9	8,995.13	5,363.87	1,103.53	2,527.73
10	8,984.18	5,344.58	1,107.10	2,532.50
11	9,000.65	5,360.72	1,109.27	2,530.67
12	8,978.45	5,355.08	1,099.08	2,524.28
<b>Average</b>	<b>9,002.63</b>	<b>5,364.58</b>	<b>1,106.31</b>	<b>2,531.75</b>

**Repeatability 1 IOPS - I/O Request Throughput Distribution Graph**

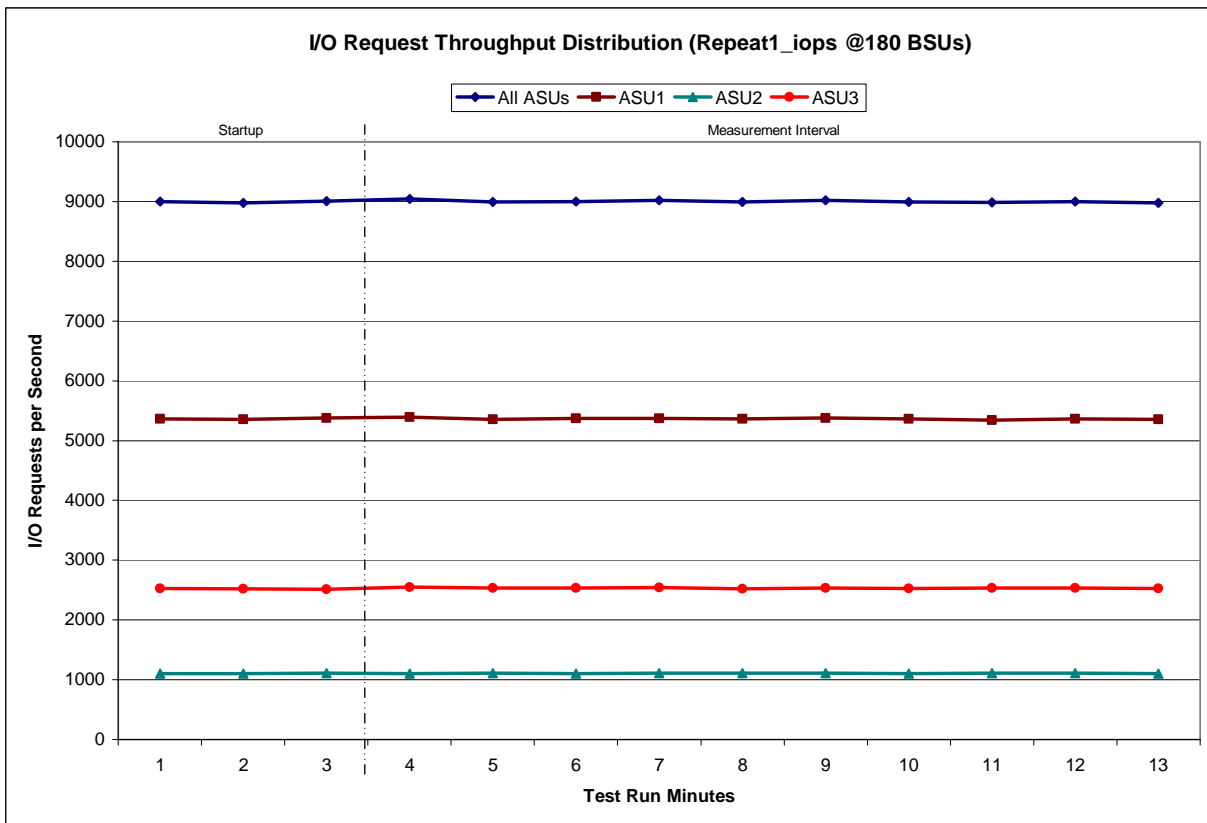

**Repeatability 1 IOPS –Average Response Time (ms) Distribution Data**

180 BSUs	Start	Stop	Interval	Duration
<i>Start-Up/Ramp-Up</i>	19:58:11	20:01:12	0-2	0:03:01
<i>Measurement Interval</i>	20:01:12	20:11:12	3-12	0:10:00
60 second intervals	All ASUs	ASU1	ASU2	ASU3
0	3.11	3.82	3.09	1.62
1	3.26	3.95	2.92	1.94
2	2.94	3.62	2.71	1.56
3	2.88	3.56	2.64	1.52
4	2.87	3.56	2.61	1.51
5	2.91	3.60	2.65	1.57
6	2.96	3.66	2.70	1.60
7	2.88	3.57	2.63	1.52
8	2.89	3.58	2.63	1.53
9	2.92	3.62	2.67	1.55
10	2.92	3.61	2.66	1.56
11	2.89	3.59	2.64	1.52
12	2.97	3.67	2.69	1.62
<b>Average</b>	2.91	3.60	2.65	1.55

**Repeatability 1 IOPS –Average Response Time (ms) Distribution Graph**

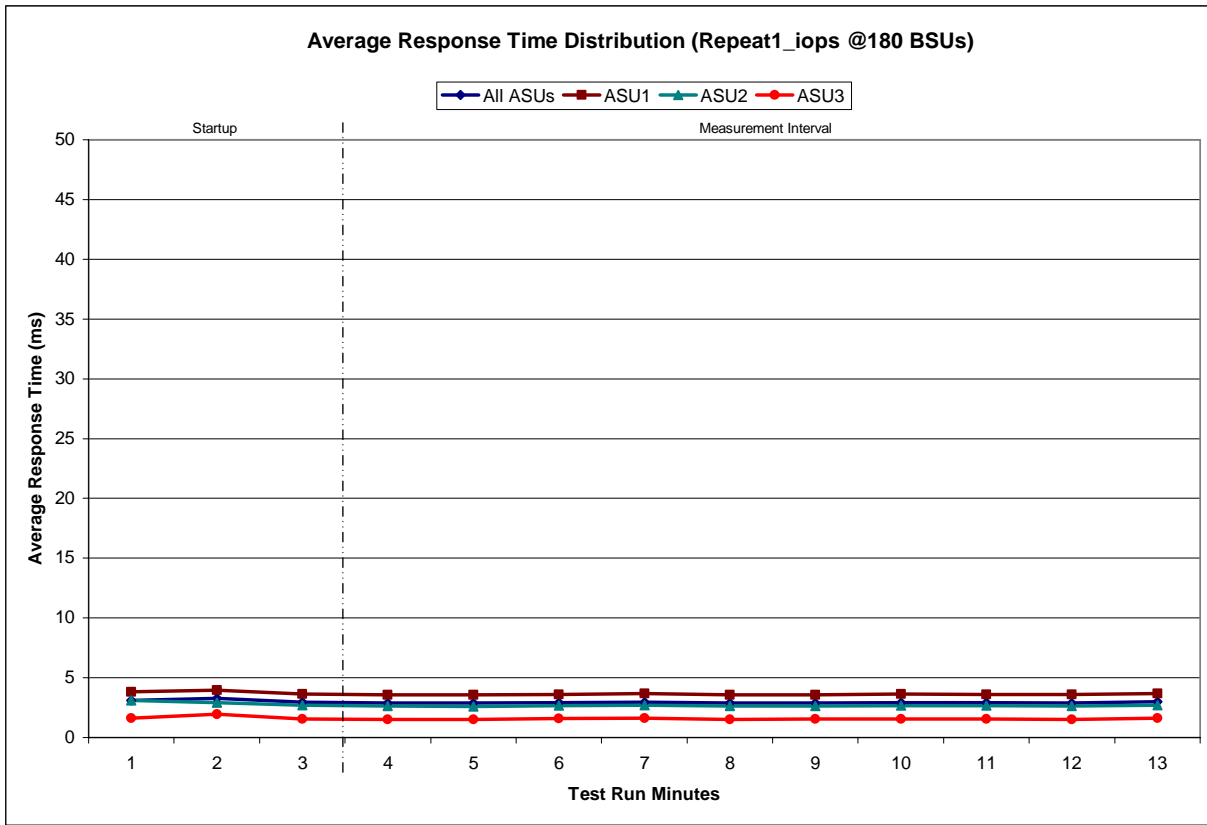

**Repeatability 2 LRT - I/O Request Throughput Distribution Data**

18 BSUs	Start	Stop	Interval	Duration
<i>Start-Up/Ramp-Up</i>	20:11:16	20:14:16	0-2	0:03:00
<i>Measurement Interval</i>	20:14:16	20:24:16	3-12	0:10:00
60 second intervals	All ASUs	ASU1	ASU2	ASU3
0	899.55	537.47	111.72	250.37
1	905.13	541.57	109.67	253.90
2	896.22	533.42	109.58	253.22
3	897.30	532.82	109.55	254.93
4	899.48	536.75	110.40	252.33
5	903.67	537.73	112.65	253.28
6	905.93	539.58	110.62	255.73
7	898.83	535.03	110.33	253.47
8	901.88	537.72	111.62	252.55
9	903.50	539.60	110.35	253.55
10	907.33	538.97	112.20	256.17
11	901.22	535.78	111.42	254.02
12	902.07	538.98	110.27	252.82
<b>Average</b>	902.12	537.30	110.94	253.89

**Repeatability 2 LRT - I/O Request Throughput Distribution Graph**

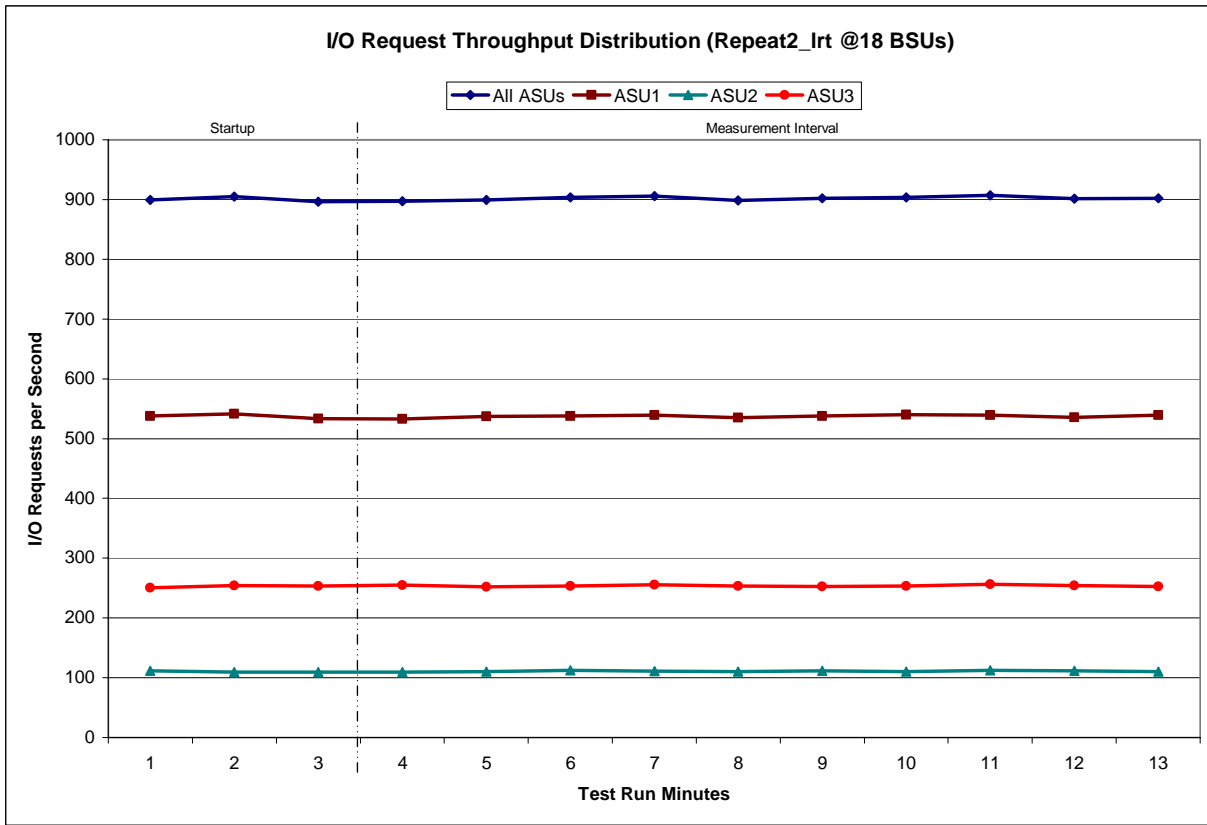

**Repeatability 2 LRT –Average Response Time (ms) Distribution Data**

18 BSUs	Start	Stop	Interval	Duration
<i>Start-Up/Ramp-Up</i>	20:11:16	20:14:16	0-2	0:03:00
<i>Measurement Interval</i>	20:14:16	20:24:16	3-12	0:10:00
60 second intervals	All ASUs	ASU1	ASU2	ASU3
0	1.99	2.60	1.99	0.66
1	1.89	2.51	1.56	0.69
2	1.86	2.47	1.64	0.67
3	1.87	2.50	1.60	0.67
4	1.86	2.48	1.57	0.67
5	1.85	2.46	1.60	0.66
6	1.85	2.46	1.62	0.69
7	1.86	2.46	1.60	0.69
8	1.87	2.48	1.59	0.69
9	1.86	2.48	1.60	0.67
10	1.86	2.48	1.59	0.68
11	1.86	2.49	1.55	0.69
12	1.87	2.47	1.61	0.69
<b>Average</b>	1.86	2.47	1.60	0.68

**Repeatability 2 LRT –Average Response Time (ms) Distribution Graph**

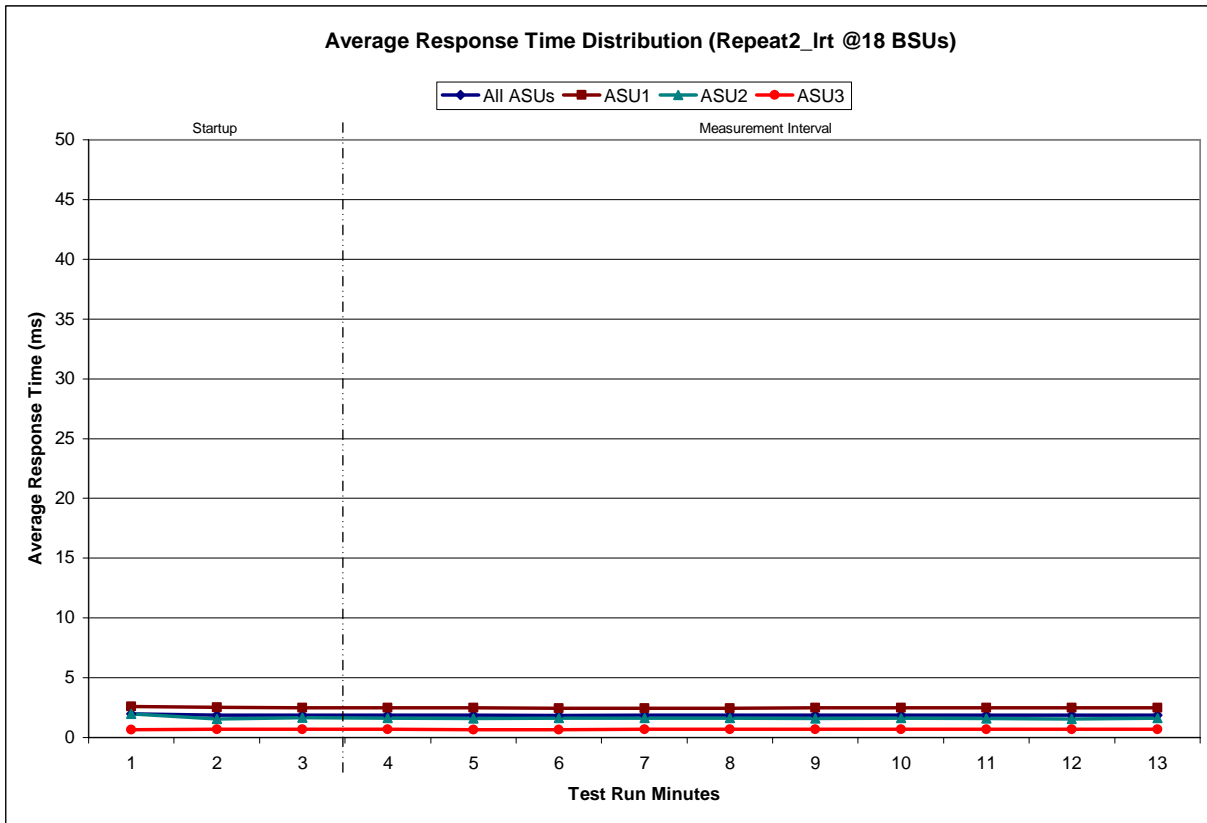

**Repeatability 2 IOPS - I/O Request Throughput Distribution Data**

180 BSUs	Start	Stop	Interval	Duration
<i>Start-Up/Ramp-Up</i>	20:24:18	20:27:19	0-2	0:03:01
<i>Measurement Interval</i>	20:27:19	20:37:19	3-12	0:10:00
60 second intervals	All ASUs	ASU1	ASU2	ASU3
0	8,989.13	5,362.50	1,111.58	2,515.05
1	9,005.30	5,371.93	1,105.02	2,528.35
2	9,008.90	5,362.73	1,106.65	2,539.52
3	9,019.90	5,382.78	1,107.32	2,529.80
4	8,981.78	5,342.28	1,108.10	2,531.40
5	9,002.77	5,366.02	1,110.33	2,526.42
6	9,007.67	5,353.48	1,113.32	2,540.87
7	9,013.02	5,377.80	1,105.05	2,530.17
8	9,000.82	5,366.27	1,116.33	2,518.22
9	8,999.38	5,353.05	1,109.65	2,536.68
10	9,009.45	5,382.17	1,101.83	2,525.45
11	9,007.02	5,366.47	1,106.20	2,534.35
12	9,000.67	5,364.00	1,109.38	2,527.28
<b>Average</b>	9,004.25	5,365.43	1,108.75	2,530.06

**Repeatability 2 IOPS - I/O Request Throughput Distribution Graph**

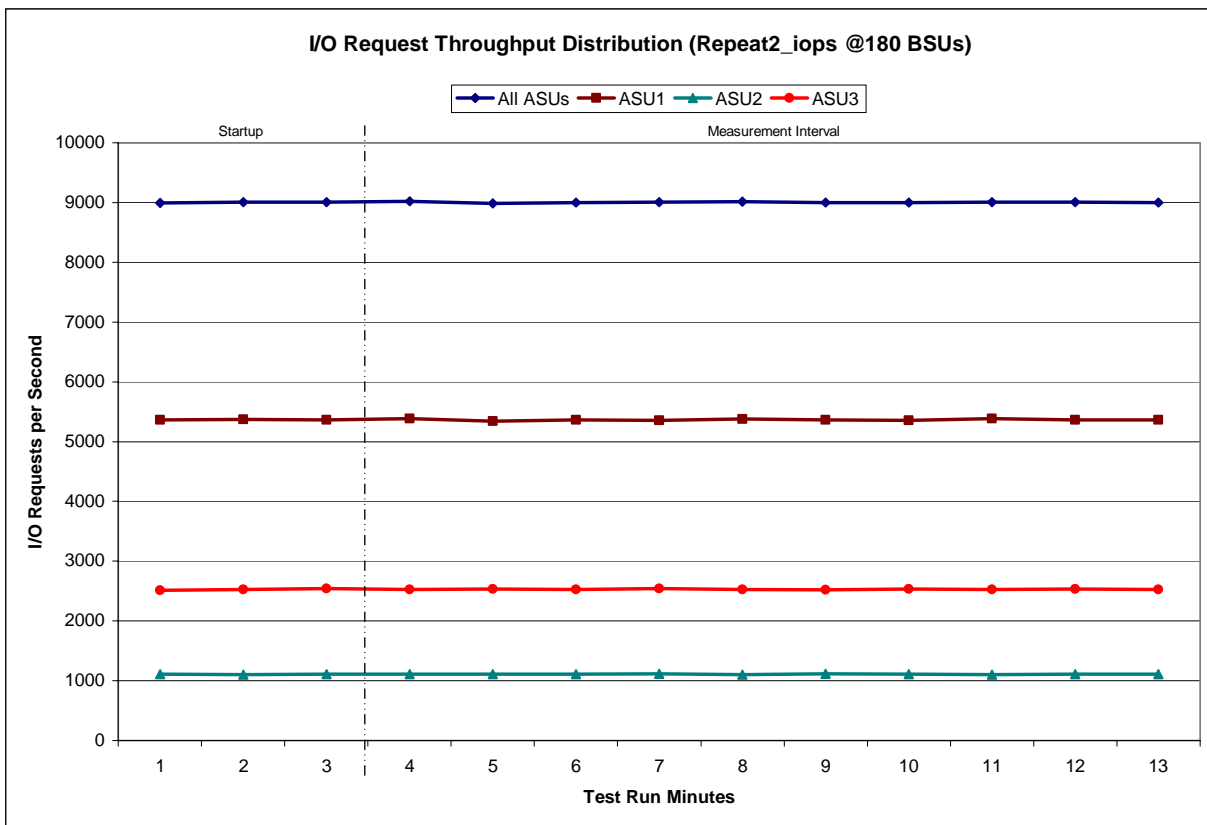

**Repeatability 2 IOPS –Average Response Time (ms) Distribution Data**

180 BSUs	Start	Stop	Interval	Duration
<i>Start-Up/Ramp-Up</i>	20:24:18	20:27:19	0-2	0:03:01
<i>Measurement Interval</i>	20:27:19	20:37:19	3-12	0:10:00
60 second intervals	All ASUs	ASU1	ASU2	ASU3
0	3.01	3.71	3.00	1.53
1	2.86	3.55	2.55	1.52
2	3.00	3.68	2.77	1.65
3	2.94	3.63	2.65	1.60
4	2.91	3.60	2.63	1.56
5	2.88	3.57	2.64	1.52
6	2.92	3.62	2.65	1.57
7	2.97	3.66	2.71	1.62
8	2.86	3.55	2.59	1.50
9	2.88	3.57	2.61	1.52
10	2.93	3.63	2.67	1.56
11	2.90	3.59	2.64	1.54
12	2.88	3.58	2.62	1.52
<b>Average</b>	2.91	3.60	2.64	1.55

**Repeatability 2 IOPS –Average Response Time (ms) Distribution Graph**

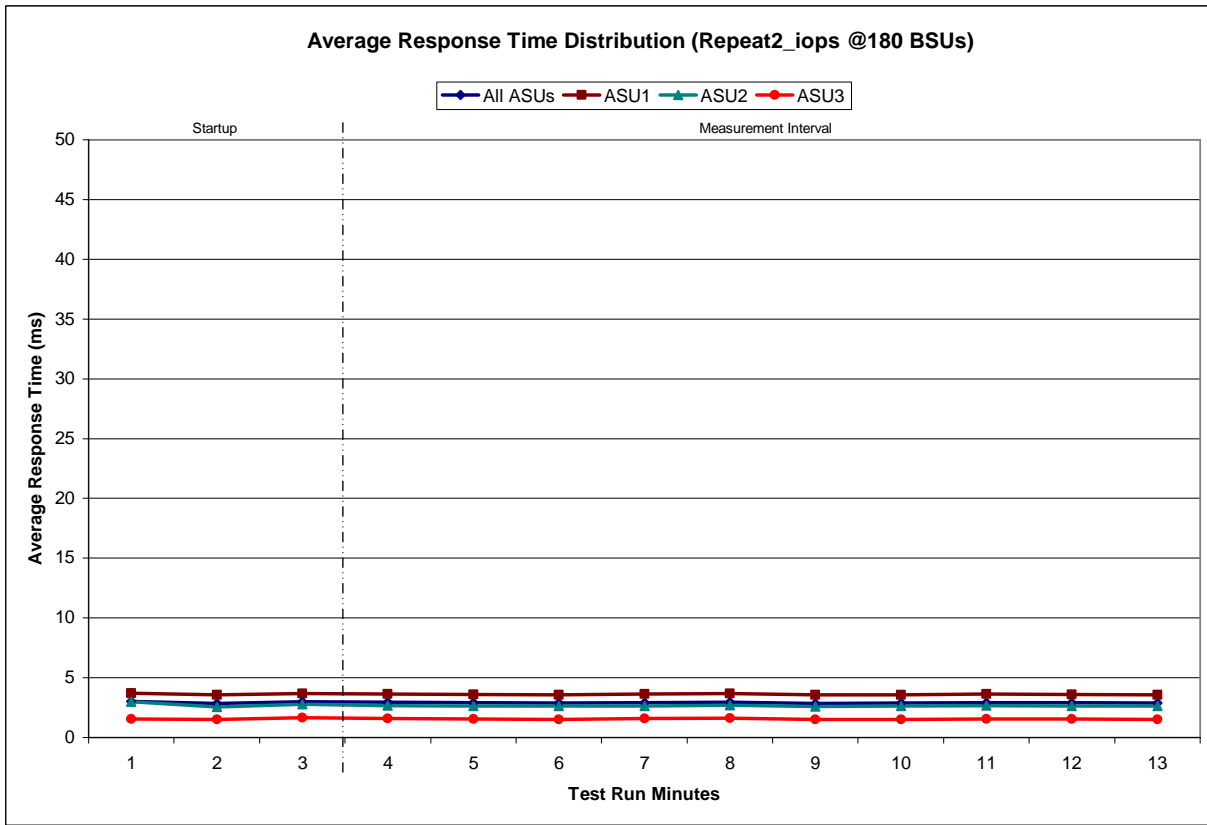

**Repeatability 1 (LRT)**  
**Measured Intensity Multiplier and Coefficient of Variation**

*Clause 3.4.3*

*IM – Intensity Multiplier: The ratio of I/Os for each I/O stream relative to the total I/Os for all I/O streams (ASU1-1 – ASU3-1) as required by the benchmark specification.*

*Clauses 5.1.0 and 5.3.13.2*

*MIM – Measured Intensity Multiplier: The Measured Intensity Multiplier represents the ratio of measured I/Os for each I/O stream relative to the total I/Os measured for all I/O streams (ASU1-1 – ASU3-1). This value may differ from the corresponding Expected Intensity Multiplier by no more than 5%.*

*Clause 5.3.13.3*

*COV – Coefficient of Variation: This measure of variation for the Measured Intensity Multiplier cannot exceed 0.2.*

	ASU1-1	ASU1-2	ASU1-3	ASU1-4	ASU2-1	ASU2-2	ASU2-3	ASU3-1
<i>IM</i>	<i>0.0350</i>	<i>0.2810</i>	<i>0.0700</i>	<i>0.2100</i>	<i>0.0180</i>	<i>0.0700</i>	<i>0.0350</i>	<i>0.2810</i>
MIM	0.0352	0.2804	0.0697	0.2096	0.0182	0.0705	0.0351	0.2813
COV	0.021	0.005	0.018	0.004	0.041	0.018	0.027	0.007

**Repeatability 1 (IOPS)**  
**Measured Intensity Multiplier and Coefficient of Variation**

	ASU1-1	ASU1-2	ASU1-3	ASU1-4	ASU2-1	ASU2-2	ASU2-3	ASU3-1
<i>IM</i>	<i>0.0350</i>	<i>0.2810</i>	<i>0.0700</i>	<i>0.2100</i>	<i>0.0180</i>	<i>0.0700</i>	<i>0.0350</i>	<i>0.2810</i>
MIM	0.0349	0.2809	0.0700	0.2101	0.0180	0.0701	0.0348	0.2112
COV	0.009	0.001	0.005	0.002	0.012	0.006	0.008	0.002

**Repeatability 2 (LRT)**  
**Measured Intensity Multiplier and Coefficient of Variation**

	ASU1-1	ASU1-2	ASU1-3	ASU1-4	ASU2-1	ASU2-2	ASU2-3	ASU3-1
<i>IM</i>	<i>0.0350</i>	<i>0.2810</i>	<i>0.0700</i>	<i>0.2100</i>	<i>0.0180</i>	<i>0.0700</i>	<i>0.0350</i>	<i>0.2810</i>
MIM	0.0347	0.2804	0.0698	0.2107	0.0179	0.0697	0.0	0.2814
COV	0.015	0.005	0.013	0.09	0.028	0.011	0.021	0.005

**Repeatability 2 (IOPS)**  
**Measured Intensity Multiplier and Coefficient of Variation**

	ASU1-1	ASU1-2	ASU1-3	ASU1-4	ASU2-1	ASU2-2	ASU2-3	ASU3-1
<i>IM</i>	<i>0.0350</i>	<i>0.2810</i>	<i>0.0700</i>	<i>0.2100</i>	<i>0.0180</i>	<i>0.0700</i>	<i>0.0350</i>	<i>0.2810</i>
MIM	0.0350	0.2808	0.0701	0.2099	0.0180	0.0701	0.0350	0.2810
COV	0.005	0.002	0.004	0.003	0.008	0.006	0.008	0.003

## Data Persistence Test

### Clause 6

*The Data Persistence Test demonstrates the Tested Storage Configuration (TSC):*

- *Is capable of maintain data integrity across a power cycle.*
- *Ensures the transfer of data between Logical Volumes and host systems occurs without corruption or loss.*

*The SPC-1 Workload Generator will write 16 block I/O requests at random over the total Addressable Storage Capacity of the TSC for ten (10) minutes at a minimum of 25% of the load used to generate the SPC-1 IOP™ primary metric. The bit pattern selected to be written to each block as well as the address of the block will be retained in a log file.*

*The Benchmark Configuration will be shutdown and restarted using a power off/power on cycle at the end of the above sequence of write operations. In addition, any caches employing battery backup must be flushed/emptied.*

*The SPC-1 Workload Generator will then use the above log file to verify each block written contains the correct bit pattern.*

### Clause 9.2.4.8

*The following content shall appear in this section of the FDR:*

1. *A listing or screen image of all input parameters supplied to the Workload Generator.*
2. *For the successful Data Persistence Test Run, a table illustrating key results. The content, appearance, and format of this table are specified in Table 9-12. Information displayed in this table shall be obtained from the Test Run Results File referenced below in #3.*
3. *For the successful Data Persistence Test Run, the human readable Test Run Results File produced by the Workload Generator.*

## SPC-1 Workload Generator Input Parameters

The SPC-1 Workload Generator input parameters for the Sustainability, IOPS, Response Time Ramp, Repeatability, and Persistence Test Runs are documented in “Appendix E: SPC-1 Workload Generator Input Parameters” on Page 67.

## Data Persistence Test Results File

A link to each test result file generated from each Data Persistence Test is listed below.

[Persistence 1 Test Results File](#)

[Persistence 2 Test Results File](#)

### Data Persistence Test Results

<b>Data Persistence Test Results</b>	
Data Persistence Test Run Number: 1	
Total Number of Logical Blocks Written	21,560,256
Total Number of Logical Blocks Verified	20,598,112
Total Number of Logical Blocks that Failed Verification	0
Time Duration for Writing Test Logical Blocks	10 minutes
Size in Bytes of each Logical Block	512
Number of Failed I/O Requests in the process of the Test	0

In some cases the same address was the target of multiple writes, which resulted in more Logical Blocks Written than Logical Blocks Verified. In the case of multiple writes to the same address, the pattern written and verified must be associated with the last write to that address.

## **PRICED STORAGE CONFIGURATION AVAILABILITY DATE**

### **Clause 9.2.4.9**

*The committed delivery data for general availability (Availability Date) of all products that comprise the Priced Storage Configuration must be reported. When the Priced Storage Configuration includes products or components with different availability dates, the reported Availability Date must be the date at which all components are committed to be available.*

*The FDR shall state: "The Priced Storage Configuration, as documented in this Full Disclosure Report will be available for shipment to customers on MMMM DD, YYYY." Where Priced Storage Configuration is the TSC Configuration Name as described in Clause 9.2.4.3.3 and MMMM is the alphanumeric month, DD is the numeric day, and YYYY is the numeric year of the date that the Priced Storage Configuration, as documented, is available for shipment to customers as described above.*

The EMC CLARiiON CX3 Model 40 as documented in this Full Disclosure Report is currently available for customer purchase and shipment.

## **PRICING INFORMATION**

### **Clause 9.2.4.11**

*A statement of the respective calculations for pricing must be included.*

### **Clause 9.2.4.11.3**

*A list of all differences between the Tested Storage Configuration (TSC) and Priced Storage Configuration must be included.*

Pricing information may found in the Tested Storage Configuration Pricing section on page 13. A list of all differences between the Tested Storage Configuration (TSC) and Priced Storage Configuration may be found in the Executive Summary portion of this document on page 13.

## **ANOMALIES OR IRREGULARITIES**

### **Clause 9.2.4.10**

*The FDR shall include a clear and complete description of any anomalies or irregularities encountered in the course of executing the SPC-1 benchmark that may in any way call into question the accuracy, verifiability, or authenticity of information published in this FDR.*

There were no anomalies or irregularities encountered during the SPC-1 Onsite Audit of the EMC CLARiiON CX3 Model 40.

## **APPENDIX A: SPC-1 GLOSSARY**

### **“Decimal” (*powers of ten*) Measurement Units**

In the storage industry, the terms “kilo”, “mega”, “giga”, “tera”, “peta”, and “exa” are commonly used prefixes for computing performance and capacity. For the purposes of the SPC workload definitions, all of the following terms are defined in “powers of ten” measurement units.

- A kilobyte (KB) is equal to 1,000 ( $10^3$ ) bytes.
- A megabyte (MB) is equal to 1,000,000 ( $10^6$ ) bytes.
- A gigabyte (GB) is equal to 1,000,000,000 ( $10^9$ ) bytes.
- A terabyte (TB) is equal to 1,000,000,000,000 ( $10^{12}$ ) bytes.
- A petabyte (PB) is equal to 1,000,000,000,000,000 ( $10^{15}$ ) bytes
- An exabyte (EB) is equal to 1,000,000,000,000,000,000 ( $10^{18}$ ) bytes

### **“Binary” (*powers of two*) Measurement Units**

The sizes reported by many operating system components use “powers of two” measurement units rather than “power of ten” units. The following standardized definitions and terms are also valid and may be used in this document.

- A kibibyte (KiB) is equal to 1,024 ( $2^{10}$ ) bytes.
- A mebibyte (MiB) is equal to 1,048,576 ( $2^{20}$ ) bytes.
- A gibibyte (GiB) is equal to 1,073,741,824 ( $2^{30}$ ) bytes.
- A tebibyte (TiB) is equal to 1,099,511,627,776 ( $2^{40}$ ) bytes.
- A pebibyte (PiB) is equal to 1,125,899,906,842,624 ( $2^{50}$ ) bytes.
- An exbibyte (EiB) is equal to 1,152,921,504,606,846,967 ( $2^{60}$ ) bytes.

## **SPC-1 Data Repository Definitions**

**Total ASU Capacity:** The total storage capacity read and written in the course of executing the SPC-1 benchmark.

**Application Storage Unit (ASU):** The logical interface between the storage and SPC-1 Workload Generator. The three ASUs (Data, User, and Log) are typically implemented on one or more Logical Volume.

**Logical Volume:** The division of Addressable Storage Capacity into individually addressable logical units of storage used in the SPC-1 benchmark. Each Logical Volume is implemented as a single, contiguous address space.

**Addressable Storage Capacity:** The total storage (sum of Logical Volumes) that can be read and written by application programs such as the SPC-1 Workload Generator.

**Configured Storage Capacity:** This capacity includes the Addressable Storage Capacity and any other storage (parity disks, hot spares, etc.) necessary to implement the Addressable Storage Capacity.

**Physical Storage Capacity:** The formatted capacity of all storage devices physically present in the Tested Storage Configuration (TSC).

**Data Protection Overhead:** The storage capacity required to implement the selected level of data protection.

**Required Storage:** The amount of Configured Storage Capacity required to implement the Addressable Storage Configuration, excluding the storage required for the three ASUs.

**Global Storage Overhead:** The amount of Physical Storage Capacity that is required for storage subsystem use and unavailable for use by application programs.

**Total Unused Storage:** The amount of storage capacity available for use by application programs but not included in the Total ASU Capacity.

## SPC-1 Data Protection Levels

**RAID5:** User data is distributed across the disks in the array. Check data corresponding to user data is distributed across multiple disks in the form of bit-by-bit parity.

**Mirroring:** Two or more identical copies of user data are maintained on separate disks.

**Other Protection Level:** Any data protection other than **RAID5** or **Mirroring**.

**Unprotected:** There is no data protection provided.

## SPC-1 Test Execution Definitions

**Average Response Time:** The sum of the Response Times for all Measured I/O Requests divided by the total number of Measured I/O Requests.

**Completed I/O Request:** An I/O Request with a Start Time and a Completion Time (see "I/O Completion Types" below).

**Completion Time:** The time recorded by the Workload Generator when an I/O Request is satisfied by the TSC as signaled by System Software.

**Data Rate:** The data transferred in all Measured I/O Requests in an SPC-1 Test Run divided by the length of the Test Run in seconds.

**Expected I/O Count:** For any given I/O Stream and Test Phase, the product of 50 times the BSU level, the duration of the Test Phase in seconds, and the Intensity Multiplier for that I/O Stream.

**Failed I/O Request:** Any I/O Request issued by the Workload Generator that could not be completed or was signaled as failed by System Software. A Failed I/O Request has no Completion Time (see “I/O Completion Types” below).

**I/O Request Throughput:** The total number of Measured I/O requests in an SPC-1 Test Run divided by the duration of the Measurement Interval in seconds.

**In-Flight I/O Request:** An I/O Request issued by the I/O Command Generator to the TSC that has a recorded Start Time, but does not complete within the Measurement Interval (see “I/O Completion Types” below).

**Measured I/O Request:** A Completed I/O Request with a Completion Time occurring within the Measurement Interval (see “I/O Completion Types” below).

**Measured Intensity Multiplier:** The percentage of all Measured I/O Requests that were issued by a given I/O Stream.

**Measurement Interval:** The finite and contiguous time period, after the TSC has reached Steady State, when data is collected by a Test Sponsor to generate an SPC-1 test result or support an SPC-1 test result.

**Ramp-Up:** The time required for the Benchmark Configuration (BC) to produce Steady State throughput after the Workload Generator begins submitting I/O Requests to the TSC for execution.

**Ramp-Down:** The time required for the BC to complete all I/O Requests issued by the Workload Generator. The Ramp-Down period begins when the Workload Generator ceases to issue new I/O Requests to the TSC.

**Response Time:** The Response Time of a Measured I/O Request is its Completion Time minus its Start Time.

**Start Time:** The time recorded by the Workload Generator when an I/O Request is submitted, by the Workload Generator, to the System Software for execution on the Tested Storage Configuration (TSC).

**Start-Up:** The period that begins after the Workload Generator starts to submit I/O requests to the TSC and ends at the beginning of the Measurement Interval.

**Shut-Down:** The period between the end of the Measurement Interval and the time when all I/O Requests issued by the Workload Generator have completed or failed.

**Steady State:** The consistent and sustainable throughput of the TSC. During this period the load presented to the TSC by the Workload Generator is constant.

**Test:** A collection of Test Phases and or Test Runs sharing a common objective.

**Test Run:** The execution of SPC-1 for the purpose of producing or supporting an SPC-1 test result. SPC-1 Test Runs may have a finite and measured Ramp-Up period, Start-Up

period, Shut-Down period, and Ramp-Down period as illustrated in the “SPC-1 Test Run Components” below. All SPC-1 Test Runs shall have a Steady State period and a Measurement Interval.

**Test Phase:** A collection of one or more SPC-1 Test Runs sharing a common objective and intended to be run in a specific sequence.

### I/O Completion Types

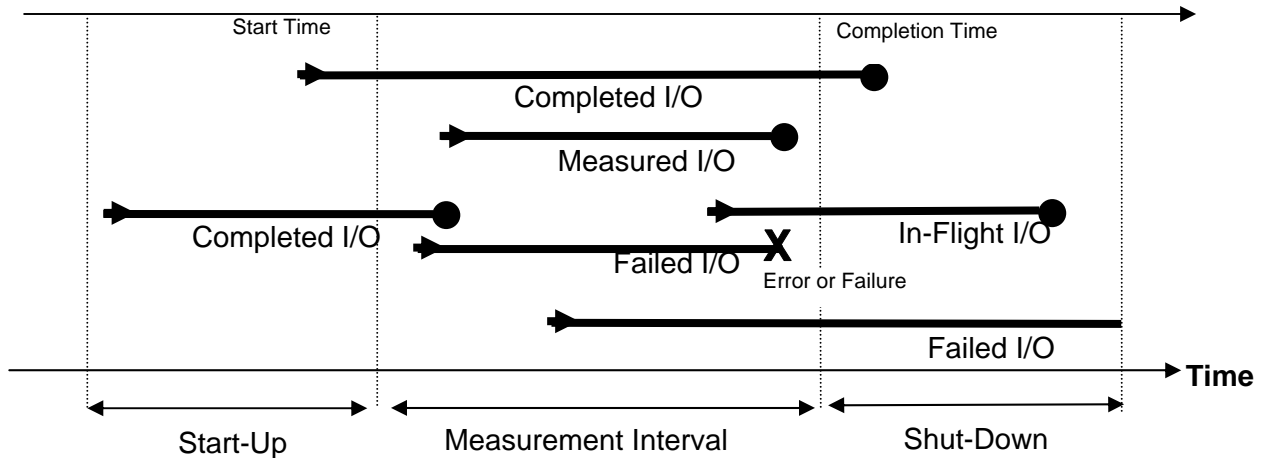

### SPC-1 Test Run Components

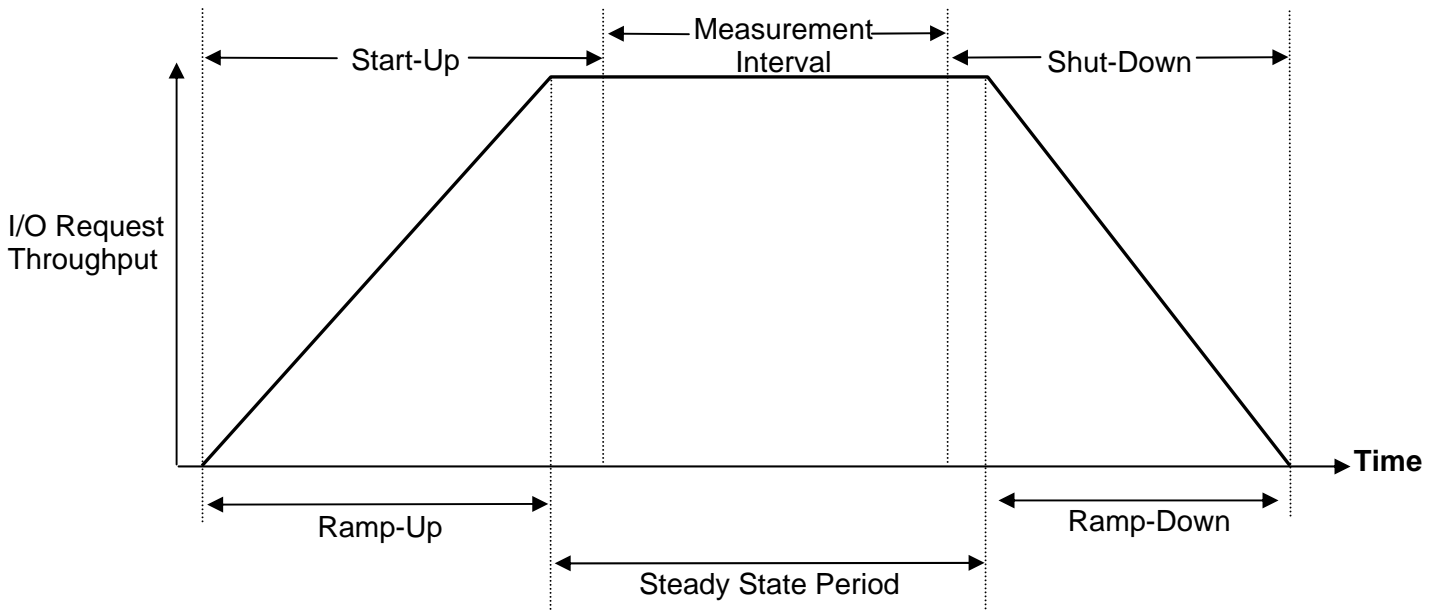

## **APPENDIX B: CUSTOMER TUNABLE PARAMETERS AND OPTIONS**

### **Windows 2003 Server**

For each HBA in the system, change the execution throttle (queue depth) from the default value of 16 to 256.

### **CX3-40 Storage System**

The following changes must be made on the CX3-40 storage system:

- Set the read policy: low water mark is 30%, high water mark is 50%.
- Set the read caches to 1616 and the write cache to 1400 MB.

## **APPENDIX C: TESTED STORAGE CONFIGURATION (TSC) CREATION**

### **Storage System**

The following sections document how to set up the storage processors and create the RAID groups and LUNs that comprise the SPC-1 data repository.

#### **Create RAID Groups**

Run the following script to create the RAID groups:

```
naviseccli -User admin -Password password -Scope 0 -h 10.61.162.55 createrg 0 0_1_0
1_3_0 0_1_1 1_3_1 0_1_2 1_3_2 0_1_3 1_3_3 0_1_4 1_3_4 0_1_5 1_3_5
naviseccli -User admin -Password password -Scope 0 -h 10.61.162.55 createrg 1 0_1_6
1_3_6 0_1_7 1_3_7 0_1_8 1_3_8 0_1_9 1_3_9 0_1_10 1_3_10 0_1_11 1_3_11
naviseccli -User admin -Password password -Scope 0 -h 10.61.162.55 createrg 2 0_2_0
1_4_0 0_2_1 1_4_1 0_2_2 1_4_2 0_2_3 1_4_3 0_2_4 1_4_4 0_2_5 1_4_5
naviseccli -User admin -Password password -Scope 0 -h 10.61.162.55 createrg 3 0_2_6
1_4_6 0_2_7 1_4_7 0_2_8 1_4_8 0_2_9 1_4_9 0_2_10 1_4_10 0_2_11 1_4_11
naviseccli -User admin -Password password -Scope 0 -h 10.61.162.55 createrg 4 0_3_0
1_5_0 0_3_1 1_5_1 0_3_2 1_5_2 0_3_3 1_5_3 0_3_4 1_5_4 0_3_5 1_5_5
naviseccli -User admin -Password password -Scope 0 -h 10.61.162.55 createrg 5 0_3_6
1_5_6 0_3_7 1_5_7 0_3_8 1_5_8 0_3_9 1_5_9 0_3_10 1_5_10 0_3_11 1_5_11
naviseccli -User admin -Password password -Scope 0 -h 10.61.162.55 createrg 6 0_4_0
1_6_0 0_4_1 1_6_1 0_4_2 1_6_2 0_4_3 1_6_3 0_4_4 1_6_4 0_4_5 1_6_5
naviseccli -User admin -Password password -Scope 0 -h 10.61.162.55 createrg 7 0_4_6
1_6_6 0_4_7 1_6_7 0_4_8 1_6_8 0_4_9 1_6_9 0_4_10 1_6_10 0_4_11 1_6_11
naviseccli -User admin -Password password -Scope 0 -h 10.61.162.55 createrg 8 0_5_0
1_7_0 0_5_1 1_7_1 0_5_2 1_7_2 0_5_3 1_7_3 0_5_4 1_7_4 0_5_5 1_7_5
naviseccli -User admin -Password password -Scope 0 -h 10.61.162.55 createrg 9 0_5_6
1_7_6 0_5_7 1_7_7 0_5_8 1_7_8 0_5_9 1_7_9 0_5_10 1_7_10 0_5_11 1_7_11
naviseccli -User admin -Password password -Scope 0 -h 10.61.162.55 createrg 100
0_1_12 0_1_13 0_2_12 0_2_13 0_3_12 0_3_13 0_3_14
naviseccli -User admin -Password password -Scope 0 -h 10.61.162.55 createrg 101
1_3_12 1_3_13 1_4_12 1_4_13 1_5_12 1_5_13 1_5_14
naviseccli -User admin -Password password -Scope 0 -h 10.61.162.55 createrg 102
0_4_12 0_4_13 0_5_12 0_5_13 0_1_14 0_2_14 0_5_14
naviseccli -User admin -Password password -Scope 0 -h 10.61.162.55 createrg 103
1_6_12 1_6_13 1_7_12 1_7_13 1_3_14 1_4_14 1_6_14
```

#### **Create LUNs**

Run the following script to create the LUNs:

```
naviseccli -User admin -Password password -Scope 0 -h 10.61.162.55 bind r1_0 0 -rg 0
-cap 296 -sp a
naviseccli -User admin -Password password -Scope 0 -h 10.61.162.55 bind r1_0 1 -rg 0
-cap 296 -sp a
naviseccli -User admin -Password password -Scope 0 -h 10.61.162.55 bind r1_0 2 -rg 0
```

```
-cap 65 -sp a
naviseccli -User admin -Password password -Scope 0 -h 10.61.162.55 bind r1_0 3 -rg 1
-cap 296 -sp a
naviseccli -User admin -Password password -Scope 0 -h 10.61.162.55 bind r1_0 4 -rg 1
-cap 296 -sp a
naviseccli -User admin -Password password -Scope 0 -h 10.61.162.55 bind r1_0 5 -rg 1
-cap 65 -sp a
naviseccli -User admin -Password password -Scope 0 -h 10.61.162.55 bind r1_0 6 -rg 2
-cap 296 -sp a
naviseccli -User admin -Password password -Scope 0 -h 10.61.162.55 bind r1_0 7 -rg 2
-cap 296 -sp a
naviseccli -User admin -Password password -Scope 0 -h 10.61.162.55 bind r1_0 8 -rg 2
-cap 65 -sp a
naviseccli -User admin -Password password -Scope 0 -h 10.61.162.55 bind r1_0 9 -rg 3
-cap 296 -sp a
naviseccli -User admin -Password password -Scope 0 -h 10.61.162.55 bind r1_0 10 -rg
3 -cap 296 -sp a
naviseccli -User admin -Password password -Scope 0 -h 10.61.162.55 bind r1_0 11 -rg
3 -cap 65 -sp a
naviseccli -User admin -Password password -Scope 0 -h 10.61.162.55 bind r1_0 12 -rg
4 -cap 296 -sp a
naviseccli -User admin -Password password -Scope 0 -h 10.61.162.55 bind r1_0 13 -rg
4 -cap 296 -sp a
naviseccli -User admin -Password password -Scope 0 -h 10.61.162.55 bind r1_0 14 -rg
4 -cap 65 -sp a
naviseccli -User admin -Password password -Scope 0 -h 10.61.162.55 bind r1_0 15 -rg
5 -cap 296 -sp a
naviseccli -User admin -Password password -Scope 0 -h 10.61.162.55 bind r1_0 16 -rg
5 -cap 296 -sp a
naviseccli -User admin -Password password -Scope 0 -h 10.61.162.55 bind r1_0 17 -rg
5 -cap 65 -sp a
naviseccli -User admin -Password password -Scope 0 -h 10.61.162.55 bind r1_0 18 -rg
6 -cap 296 -sp b
naviseccli -User admin -Password password -Scope 0 -h 10.61.162.55 bind r1_0 19 -rg
6 -cap 296 -sp b
naviseccli -User admin -Password password -Scope 0 -h 10.61.162.55 bind r1_0 20 -rg
6 -cap 65 -sp b
naviseccli -User admin -Password password -Scope 0 -h 10.61.162.55 bind r1_0 21 -rg
7 -cap 296 -sp b
naviseccli -User admin -Password password -Scope 0 -h 10.61.162.55 bind r1_0 22 -rg
7 -cap 296 -sp b
naviseccli -User admin -Password password -Scope 0 -h 10.61.162.55 bind r1_0 23 -rg
7 -cap 65 -sp b
naviseccli -User admin -Password password -Scope 0 -h 10.61.162.55 bind r1_0 24 -rg
8 -cap 296 -sp b
naviseccli -User admin -Password password -Scope 0 -h 10.61.162.55 bind r1_0 25 -rg
8 -cap 296 -sp b
naviseccli -User admin -Password password -Scope 0 -h 10.61.162.55 bind r1_0 26 -rg
```

```
8 -cap 65 -sp b
naviseccli -User admin -Password password -Scope 0 -h 10.61.162.55 bind r1_0 27 -rg
9 -cap 296 -sp b
naviseccli -User admin -Password password -Scope 0 -h 10.61.162.55 bind r1_0 28 -rg
9 -cap 296 -sp b
naviseccli -User admin -Password password -Scope 0 -h 10.61.162.55 bind r1_0 29 -rg
9 -cap 65 -sp b
naviseccli -User admin -Password password -Scope 0 -h 10.61.162.55 bind r5 100 -rg
100 -cap 100 -sp a
naviseccli -User admin -Password password -Scope 0 -h 10.61.162.55 bind r5 101 -rg
100 -cap 100 -sp b
naviseccli -User admin -Password password -Scope 0 -h 10.61.162.55 bind r5 102 -rg
100 -cap 100 -sp a
naviseccli -User admin -Password password -Scope 0 -h 10.61.162.55 bind r5 103 -rg
100 -cap 100 -sp b
naviseccli -User admin -Password password -Scope 0 -h 10.61.162.55 bind r5 104 -rg
100 -cap 100 -sp a
naviseccli -User admin -Password password -Scope 0 -h 10.61.162.55 bind r5 105 -rg
100 -cap 100 -sp b
naviseccli -User admin -Password password -Scope 0 -h 10.61.162.55 bind r5 106 -rg
100 -cap 100 -sp a
naviseccli -User admin -Password password -Scope 0 -h 10.61.162.55 bind r5 107 -rg
100 -cap 100 -sp b
naviseccli -User admin -Password password -Scope 0 -h 10.61.162.55 bind r5 108 -rg
101 -cap 100 -sp a
naviseccli -User admin -Password password -Scope 0 -h 10.61.162.55 bind r5 109 -rg
101 -cap 100 -sp b
naviseccli -User admin -Password password -Scope 0 -h 10.61.162.55 bind r5 110 -rg
101 -cap 100 -sp a
naviseccli -User admin -Password password -Scope 0 -h 10.61.162.55 bind r5 111 -rg
101 -cap 100 -sp b
naviseccli -User admin -Password password -Scope 0 -h 10.61.162.55 bind r5 112 -rg
101 -cap 100 -sp a
naviseccli -User admin -Password password -Scope 0 -h 10.61.162.55 bind r5 113 -rg
101 -cap 100 -sp b
naviseccli -User admin -Password password -Scope 0 -h 10.61.162.55 bind r5 114 -rg
101 -cap 100 -sp a
naviseccli -User admin -Password password -Scope 0 -h 10.61.162.55 bind r5 115 -rg
101 -cap 100 -sp b
naviseccli -User admin -Password password -Scope 0 -h 10.61.162.55 bind r5 116 -rg
102 -cap 100 -sp a
naviseccli -User admin -Password password -Scope 0 -h 10.61.162.55 bind r5 117 -rg
102 -cap 100 -sp b
naviseccli -User admin -Password password -Scope 0 -h 10.61.162.55 bind r5 118 -rg
102 -cap 100 -sp a
naviseccli -User admin -Password password -Scope 0 -h 10.61.162.55 bind r5 119 -rg
102 -cap 100 -sp b
naviseccli -User admin -Password password -Scope 0 -h 10.61.162.55 bind r5 120 -rg
```

```
102 -cap 100 -sp a
naviseccli -User admin -Password password -Scope 0 -h 10.61.162.55 bind r5 121 -rg
102 -cap 100 -sp b
naviseccli -User admin -Password password -Scope 0 -h 10.61.162.55 bind r5 122 -rg
102 -cap 100 -sp a
naviseccli -User admin -Password password -Scope 0 -h 10.61.162.55 bind r5 123 -rg
102 -cap 100 -sp b
naviseccli -User admin -Password password -Scope 0 -h 10.61.162.55 bind r5 124 -rg
103 -cap 100 -sp a
naviseccli -User admin -Password password -Scope 0 -h 10.61.162.55 bind r5 125 -rg
103 -cap 100 -sp b
naviseccli -User admin -Password password -Scope 0 -h 10.61.162.55 bind r5 126 -rg
103 -cap 100 -sp a
naviseccli -User admin -Password password -Scope 0 -h 10.61.162.55 bind r5 127 -rg
103 -cap 100 -sp b
naviseccli -User admin -Password password -Scope 0 -h 10.61.162.55 bind r5 128 -rg
103 -cap 100 -sp a
naviseccli -User admin -Password password -Scope 0 -h 10.61.162.55 bind r5 129 -rg
103 -cap 100 -sp b
naviseccli -User admin -Password password -Scope 0 -h 10.61.162.55 bind r5 130 -rg
103 -cap 100 -sp a
naviseccli -User admin -Password password -Scope 0 -h 10.61.162.55 bind r5 131 -rg
103 -cap 100 -sp b
```

After executing the above two scripts, execute the following:

- Use the NaviSphere GUI to add LUNs 100 through 131 to the Reserved LUN Pool for SnapView cache usage.
- Use the NaviSphere GUI to create a SnapView LUN for each source LUN (LUNs 0-29).
- From the Navisphere GUI, change the following caching parameters:
  - Set the read policy: low water mark is 30%, high water mark is 50%.
  - Set the read caches to 1616 and the write cache to 1400 MB.

## Host System

The steps required to configure the Host System are listed below:

- Install Microsoft Windows Server 2003 Service Pack 2.
- Install and setup two Qlogic 2462 HBAs.
- Install Qlogic SANsurfer HBA management software.
- Install the Navisphere command line utility and GUI interface.
- Install EMC PowerPath (version 5.0.0.94) for Windows 2003 for load balancing.
- Set the “Execution Throttle” (also known as HBA queue depth) setting on each FCP port from default of 16 to 256 using the SANsurfer HBA management software.

- The steps that follow are required to define the Windows partitions, volumes, and stripe sets used by the SPC-1 benchmark.
  1. Using Navisphere, create a storage group. Add LUNs 0, 3, 6, 9, 12, 15, 18, 21, 24, 27 to the storage group.
  2. Using the Windows disk manager, rescan the disks. 10 new disks will show up.
  3. Use `diskpar.exe` to create an aligned partition on each new disk: (user input is in **bold**). Note that the 8MB “aligned” partitions created in the following procedure were created to ensure that the remaining space on each of the 30 disks would be properly aligned on a 4K boundary under Windows. These partitions remained unformatted and were not used during the benchmark

```
C:\>diskpar -s 1
Set partition can only be done on a raw drive.
You can use Disk Manager to delete all existing partitions
Are you sure drive 1 is a raw device without any partition? (Y/N) Y

---- Drive 1 Geometry Information ----
Cylinders = 38640
TracksPerCylinder = 255
SectorsPerTrack = 63
BytesPerSector = 512
DiskSize = 317824819200 (Bytes) = 303101 (MB)

We are going to set the new disk partition.
All data on this drive will be lost. continue (Y/N)? Y

Please specify starting offset (in sectors): 64
Please specify partition length (in MB) (Max = 102398): 8

Done setting partition.
---- New Partition information ----
StartingOffset = 32768
PartitionLength = 8388608
HiddenSectors = 64
PartitionNumber = 1
PartitionType = 7

You now should use Disk Manager to format this partition

C:\> diskpar -s 2
.....and so on for each disk.
```

4. Start Windows Disk Manager.
5. Convert the 10 disks to Dynamic Disks.
6. Create a striped volume across the large remaining space on the 10 disks. This will be drive letter “F:”. Do not format “F:”. Drive F: will be ASU1.

7. Using Navisphere, add LUNs 1, 4, 7, 10, 13, 16, 19, 22, 25, 28 to the existing storage group.
8. Repeat steps 2 through 6 to create drive H. "H" will be used for ASU2.
9. Using Navisphere add LUNs 2, 5, 8, 11, 14, 17, 20, 23, 26 29 to the existing storage group.
10. Repeat steps 2 through 6 to create drive J. "J" will be used for ASU3.

### **Brocade FCP Switches**

Connect the physical connections from the Host System to the CX3-40 as illustrated on page 14 (*Benchmark Configuration/ Tested Storage Configuration Diagram*).

## **APPENDIX D: SPC-1 WORKLOAD GENERATOR STORAGE COMMANDS AND PARAMETERS**

The content of SPC-1 Workload Generator command and parameter file, used in this benchmark, is listed below.

```
javaparms="-Xmx512m"  
sd=asu1_1,lun=\\.\\F:  
sd=asu2_1,lun=\\.\\H:  
sd=asu3_1,lun=\\.\\J:
```

## **APPENDIX E: SPC-1 WORKLOAD GENERATOR INPUT PARAMETERS**

### **Primary Metrics Test, Repeatability Test, and Persistence Test Run 1**

The following script was used to execute the Primary Metrics Test (*Sustainability Test Phase, IOPS Test Phase, and Response Time Ramp Test Phase*), Repeatability Test (*Repeatability Test Phase 1 and Repeatability Test Phase 2*), and Persistence Test Run 1 in an uninterrupted sequence.

```
java -Xmx512m metrics -b 180
java -Xmx512m repeat1 -b 180
java -Xmx512m repeat2 -b 180
java -Xmx512m persist1 -b 180
rem java -Xmx512m persist2
```

### **Persistence Test Run 2**

The following CLI command was used to execute Persistence Test Run 2:

```
java -Xmx512m persist2
```

**APPENDIX F: THIRD-PARTY QUOTE**

Listed below is a third-party quote for the priced storage configuration with the exception of the Brocade switches, which were supplied by Network Appliance, Inc.



Alta Technologies, Inc  
3850 Annapolis Lane, Suite 100  
Plymouth, MN 55447

Phone: 800-546-2582 x327  
Direct dial: 763-475-5327  
Fax number: 763-475-0409

---

**QUOTE FOR:** Network Appliance  
7301 Kit Creek Road, Building 1  
Research Triangle Park, NC 27709  
Office: 919.476.5700

1/4/2007

Quantity	Description	Unit list			Total
		price	Disc		
1	1 CX3-40C-FD - SPE-FIELD INSTALL	EA	42,300	0%	42,300
2	11 CX-4PDAE-FD - 4G DAE FIELD INSTALL	EA	5,900	0%	64,900
3	150 CX-4G15-148 - 148GB 15K 4GB FC	EA	1,645	0%	246,750
4	1 V-CX4014615K - VAULT PACK CX3-40 148GB 15K 4GB DRIVES QTY 5	EA	8,225	0%	8,225
5	4 FC2-HSSDC-8M - 8M HSSDC2 to HSSDC2 bus cbl	EA	600	0%	2,400
6	1 PP-WN-KIT - POWERPATH WINDOWS KIT	EA	0	0%	0
7	1 NAV-ENKIT - NAVI ENTERPRISE MEDIA	EA	0	0%	0
8	8 NAVAGT-WINKIT - NAVI AGENT WINDOWS MEDIA	EA	0	0%	0
9	1 SV3-KIT - SNAPVIEW MEDIA CX3-XX SER	EA	0	0%	0
10	8 UTIL-WIN - Windows Software Utilities	EA	0	0%	320
11	1 CX34C-KIT - CS3-40C DOCS AND RTU KIT	EA	0	0%	0
12	1 C-MODEM-US - CLARiiON SERVICE MODEM-US	EA	0	0%	0
13	1 NAV34-EN - NAVI MGR CX3-40 ENTPR LIC	EA	56,000	0%	56,000
14	1 SV34 - SNAPVIEW CX3-40	EA	17,400	0%	17,400
15	1 PP-WN-WG - PPATH WINDOWS WGR	EA	1,440	0%	1,440
16	1 PS-BAS-PP1 - POWERPATH 1HOST QS	EA	1,330	0%	1,330
17	1 PS-BAS-PMBLK - POWERPATH 1HOST QS	EA	1,970	0%	1,970
18	1 M-PRESW-001- premium software support	EA	33,929	0%	33,929
19	1 M-PRESW-004 - premium software support - open SW	EA	777	0%	777
20	1 WU-PREHW-001- premium hardware support	EA	31,317	0%	31,317
21	2 GLA2462-E-5P - 2 PORT 4GB PCI-X	EA	1,700	0%	3,400
Hardware summary			\$ 367,875	0%	\$ 367,975
Software summary			\$ 59,760	0%	\$ 77,160
Services summary			\$ 3,300	0%	\$ 3,300
Prepaid software maintenance (3YR-4HOURL)			\$ 34,706	0%	\$ 34,706
Hardware warranty upgrade summary (3YR 4HOURL)			\$ 31,317	0%	\$ 31,317
<b>Total price (USD)</b>					<b>\$ 514,458</b>

## **APPENDIX G: USE OF EMC'S SNAPVIEW™**

EMC's SnapView(tm) technology was enabled to provide multiple point-in-time space-efficient copies of the SPC-1 data repository during the three-hour Sustainability Test Run, as well as immediately after Persistence Test Run 1.

A SnapView session was started, creating a point-in-time copy approximately one (1) hour after the start of the Sustainability Test Run. That copy was then deleted and a second copy was created approximately one (1) hour later. That second copy was deleted immediately before the termination of the Sustainability Test Run. A final Snapview session was used to make a copy after the completion of Persistence Test Run 1 with no intervening activity.

Verification of the above SnapView execution and accuracy of the SnapView copy was accomplished using the Persistence Test as follows:

1. Persistence Test Run 1 writes specific content to randomly selected locations in the SPC-1 data repository, recording the locations selected and content written. After the storage system has been power cycled, Persistence Test Run 2 is executed to verify the correct content at the correct locations written by Persistence Test Run 1. See Clause 6 of the SPC-1 specification for the details of the Persistence Test.
2. Immediately after the completion of Persistence Test Run 1 and subsequent completion of the final SnapView copy, the ASU data repository content was changed using a 'scribble' utility.
3. Persistence Test Run 2 was then executed and failed because the activity in step #2 changed the content in the locations utilized by Persistence Test Run 1.
4. The final SnapView session was then used to return the SPC-1 data repository to the 'point in time' immediately after Persistence Test Run 1 successfully completed.
5. Persistence Test Run 2 was then executed and completed successfully, which verified application of the final SnapView copy in step #4 returned the SPC-1 repository to the 'point in time' immediately after successful completion of Persistence Test Run 1.