



SPC BENCHMARK 1™ (SPC-1™)

Official Specification

Revision 3.9.1 – Effective 15 July 2020

“The First Industry Standard Storage Benchmark”

Storage Performance Council (SPC)

PO Box 3504

Redwood City, CA 94064-3504

Phone (650) 556-9384

www.storageperformance.org

Copyright © 2001 - 2020 Storage Performance Council

SPC Membership as of 24 August 2018

Accelstor Ltd.	Kaminario, Inc.
Amazon, Inc.	Korea Advanced Institute of Science and Technology
Austin Automation Center – Department of Veteran Affairs	Lenovo
Cybernetics	MacroSAN Technologies Co. Ltd.
Datacore Software, Inc.	NEC Corporation
Dell, Inc.	NetApp, Inc.
Elastifile, Inc.	Oracle Corporation
ETRI	Pennsylvania State University
Foundation for Research and Technology – Institute of Computer Science	Pure Storage, Inc.
Fujitsu America, Inc.	Ruijie Networks Co. Ltd.
FusionStack	Samsung Information Systems, America
Gradient Systems	Sanmina
The George Washington University	Seagate Technology LLC
Hewlett-Packard Enterprise	SuperMicro Computer, Inc.
Hitachi Data Systems	Telecommunication Technology Association (TTA)
Hongik University	University of California, Santa Cruz
Huawei Technologies Co., Ltd.	University of Patras
IBM Corporation	Vexata
Imation, Corp	Western Digital Corporation
Infotrend Technology, Inc.	
Inspur Corporation	

The SPC would also like to acknowledge the contributions of the members who helped to create the initial release of version 3 of the SPC-1 specification Austin Automation Center – Department of Veteran Affairs, DataDirect Networks, Datera, Inc., Dell, Inc., Dot Hill Systems Corp., EMC Corporation, Foundation for Research and Technology – Institute of Computer Science, Fujitsu America, Inc., The George Washington University, Hewlett-Packard Company, Hitachi Data Systems, Hongik University, Huawei Technologies Co., Ltd., IBM Corporation, Imation, Corp. Infotrend Technology, Inc., Kaminario, Inc., Korea Advanced Institute of Science and Technology, LSI Corporation, NEC Corporation. NetApp, Inc., Nimbus Data Systems, Inc., Oracle Corporation, Pennsylvania State University, QLogic Corporation, Samsung Information Systems, America. SanDisk Corporation, Seagate Technology LLC, Silicon Graphics International, Skyera, Inc.. SolidFire, Inc., Symantec Corporation, Toshiba America Information Systems, Inc., University of California, Santa Cruz, University of Patras, Violin Memory, Inc.. Western Digital Corporation. X-IO Technologies

Document History

Effective Date	Version	Description
9 October 2001	1.0	The first official release of the SPC Benchmark-1™ (SPC-1) specification. Approved unanimously by the SPC membership.
	2.0	Not released
21 July 2014	3.0	First major revision of the specification.
18 November 2015	3.1	Additional VERIFY test, improved alignment with post-processing tools
1 July 2016	3.2	Simplified capacity reporting New audit model New FDR content and format
15 January 2017	3.3	Minor editorial cleanup (removal of comments) Strike onsite/offsite audit method discussion Require protection against data loss from single point of failure Clarified terms and definitions Refined Steady State requirements Add pricing disclaimer to Executive Summary Require disclosure of space optimization techniques (e.g., compression or deduplication)
15 May 2017	3.4	Clause 4: Clarify BC/TSC relationship, remove term “system software”, and clarify role of hosts systems and workload generator instances. Clause 5: Reinforce the requirements that all workload generators must access of Logical Volumes and ASUs, and common storage devices. Clause 7: Add requirement to preserve all committed data Minor editorial cleanup
18 September 2017	3.5	Remove remaining references to system software, which is no longer a defined term. Require disclosure of data protection methodology
15 February 2018	3.6	Definition of Physical Free Space (2.5) Space optimization disclosure requirements (2.7, 5.2.3.2, 6.3.8.8, 10.8.5.3) Scaler shift in price-performance metrics (8.2.3)
22 July 2018	3.7	Correction of test durations in PERSIST_2 (7.4.1) Allowance for additional disclosure items at auditor’s discretion (10.1)

Effective Date	Version	Description
27 October 2019	3.8	Correct SER calculation (2.7.4, 10.8.5.3) Update membership roster
27 May 2020	3.9	Creation of stand-alone Energy Extension (Clause 12) Introduction of Glossary as Appendix C Overhaul of Pricing requirements and reliance on <i>SPC Pricing Guide</i> (Clause 9) Rework of Executive Summary format

Table of Contents

SPC Membership as of 24 August 2018	ii
Document History.....	2
Table of Contents.....	4
Table of Tables.....	6
Table of Figures	6
CLAUSE 0 INTRODUCTION.....	8
0.1 PREAMBLE	8
0.2 GENERAL GUIDELINES.....	9
0.3 MEASUREMENT GUIDELINES.....	10
0.4 RELATED DOCUMENTS.....	10
0.5 DOCUMENT CONVENTIONS	11
0.6 DISCLAIMER.....	11
CLAUSE 1 WORKLOAD ENVIRONMENT	12
1.1 BUSINESS AND APPLICATION ENVIRONMENT	12
1.2 HIGH-LEVEL WORKLOAD MODEL.....	12
CLAUSE 2 STORAGE CAPACITY & CONTENT.....	14
2.1 STORAGE CAPACITY HIERARCHY	14
2.2 STORAGE DEVICES & PHYSICAL STORAGE CAPACITY.....	14
2.3 LOGICAL VOLUMES	14
2.4 APPLICATION STORAGE UNITS & ASU CAPACITY	14
2.5 PHYSICAL FREE SPACE	16
2.6 ASU CONTENT MIX	18
2.7 SPACE OPTIMIZATION	19
2.8 DATA PROTECTION AND DATA ACCESS.....	19
2.9 PHYSICAL CAPACITY UTILIZATION.....	20
CLAUSE 3 WORKLOAD AND I/O OPERATION PROFILE.....	21
3.1 OVERVIEW.....	21
3.2 I/O STREAM.....	21
3.3 I/O COMMAND OR I/O REQUEST.....	22
3.4 DEFINITIONS.....	22
3.5 SPC-1 PARAMETER TYPES	23
3.6 SPC-1 WORKLOAD PARAMETERS.....	26
3.7 DETAILED WORKLOAD DESCRIPTION	30
CLAUSE 4 BENCHMARK CONFIGURATION & TESTED STORAGE CONFIGURATION	34
4.1 COMPONENT AVAILABILITY AND SUPPORT	34
4.2 BENCHMARK CONFIGURATION COMPONENTS	34
4.3 BENCHMARK CONFIGURATION EXAMPLES	34
4.4 TESTED STORAGE CONFIGURATION COMPONENTS.....	35
4.5 TESTED STORAGE PRODUCT	39

CLAUSE 5	SPC TEST METHODOLOGY	40
5.1	DEFINED TERM CLARIFICATIONS	40
5.2	REQUIREMENTS AND CONSTRAINTS	41
CLAUSE 6	SPC-1 MEASUREMENT REQUIREMENTS (EXECUTION RULES)	47
6.1	OVERVIEW.....	47
6.2	GENERAL GUIDELINES.....	47
6.3	PRIMARY METRICS TEST.....	47
CLAUSE 7	DATA PERSISTENCE REQUIREMENTS AND TEST	52
7.1	INTRODUCTION	52
7.2	PERSISTENCE REQUIREMENTS	52
7.3	PERSISTENCE TEST VALIDATION	52
7.4	TEST PHASE SUMMARY.....	52
CLAUSE 8	REPORTED DATA.....	54
8.1	SPC-1 REPORTED DATA.....	54
8.2	SPC-1 PRIMARY METRICS.....	54
8.3	SPC-1 SECONDARY METRICS.....	55
8.4	SPC-1 ASSOCIATED DATA.....	56
8.5	SPC-1 RESULTS – PUBLIC USE REQUIREMENTS	57
CLAUSE 9	PRICING	58
9.1	OVERVIEW.....	58
9.2	PRICED COMPONENTS.....	58
9.3	MAINTENANCE DURATION	58
9.4	PRICING RELATED DATA.....	58
9.5	PRICING DISCLOSURE	58
CLAUSE 10	FULL DISCLOSURE REPORT	59
10.1	OVERVIEW	59
10.2	FULL DISCLOSURE REPORT REQUIREMENTS	59
10.3	DOCUMENT CONTENTS	59
10.4	FRONT MATTER.....	60
10.5	EXECUTIVE SUMMARY.....	61
10.6	PRICING DETAILS	63
10.7	PUBLICATION DETAILS.....	63
10.8	CONFIGURATION INFORMATION	65
10.9	BENCHMARK EXECUTION RESULTS	74
10.10	BENCHMARK EXTENSION RESULTS.....	77
CLAUSE 11	MEASUREMENT, AUDIT, AND RESULTS SUBMISSION.....	78
11.1	INTRODUCTION.....	78
11.2	TYPES OF NEW SPC-1 RESULTS	78
11.3	SPC-1 AUDIT.....	78
11.4	SPC-1 AUDITED MEASUREMENTS.....	79
11.5	AUDITOR.....	79
11.6	GENERAL AUDIT PROCEDURES	79
11.7	CLAUSE SPECIFIC AUDIT PROCEDURES	80

11.8	SPC-1 AUDIT CERTIFICATION	82
11.9	FDR VERIFICATION.....	83
11.10	SPC-1 MEASUREMENT SUBMISSION.....	83
11.11	SPC PEER REVIEW	84
11.12	CREATING A NEW SPC-1 RESULT BASED ON AN EXISTING SPC-1 RESULT	84
11.13	SPC-1 RESULT REVISIONS.....	84
Appendix A	Letter of Good Faith Template	86
Appendix B	The Hierarchical Reuse Random Walk.....	87
Appendix C	Glossary	88
Appendix D	Sample Executive Summary	96
Index.....		98

Table of Tables

TABLE 2-1	ASU CONTENT MIX	18
TABLE 3-1	SMIX TRANSFER SIZE DISTRIBUTION.....	30
TABLE 3-2	ASU 1 PARAMETER TYPES AND VALUES.....	31
TABLE 3-3	ASU 2 PARAMETER TYPES AND VALUES.....	32
TABLE 3-4	ASU 3 PARAMETER TYPES AND VALUES.....	33
TABLE 6-1	PRIMARY METRICS TEST PHASES	48
TABLE 7-1	PERSISTENCE TEST PHASES	52
TABLE 8-1	OVERALL RESPONSE TIME COMPONENTS	55
TABLE 10-1	CONTACT INFORMATION.....	63
TABLE 10-2	REVISION INFORMATION AND KEY DATES.....	63
TABLE 10-3	SOURCE SPC-1 RESULT INFORMATION.....	64
TABLE 10-4	HOST SYSTEM.....	65
TABLE 10-5	TESTED STORAGE CONFIGURATION	66
TABLE 10-6	LOGICAL VOLUME ADDRESSABLE CAPACITY AND ASU MAPPING	72
TABLE 10-5	PHYSICAL CAPACITY AND STORAGE DEVICE SUMMARY	72
TABLE 10-7	SPACE UTILIZATION RESULTS.....	73
TABLE 10-8	SPACE OPTIMIZATION RATIOS	74
TABLE 10-6	REPEATABILITY TEST RESULTS.....	76
TABLE 10-11	DATA PERSISTENCE TEST RESULTS	77

Table of Figures

FIGURE 2-1	SAMPLE ASU- TO- LOGICAL VOLUME ADDRESS MAPPINGS	15
FIGURE 2-2	PHYSICAL FREE SPACE: EXAMPLE 1	17
FIGURE 3-1	WORKLOAD COMPONENTS	21
FIGURE 4-1	SAMPLE BENCHMARK CONFIGURATIONS: DIRECT ATTACH STORAGE	34
FIGURE 4-2	EXTERNAL STORAGE CONFIGURATIONS.....	35
FIGURE 4-3	EMBEDDED OR EXTERNAL CONTROLLER – EXTERNAL STORAGE DEVICES	
	36	
FIGURE 4-4	EMBEDDED STORAGE CONTROLLER – EMBEDDED STORAGE DEVICES	37
FIGURE 4-5	NETWORK STORAGE –EXTERNAL STORAGE CONTROLLER AND STORAGE	
	DEVICES	38
FIGURE 5-1	TEST PHASE	40
FIGURE 5-2	IO REQUESTS FROM MULTIPLE HOSTS.....	44

FIGURE 5-3 MEASUREMENT BOUNDARY	45
FIGURE 5-4 MEASUREMENT BOUNDARY	46
FIGURE 6-1 TEST EXECUTION OVERVIEW.....	50
FIGURE 10-1 BC/TSC CONFIGURATION DIAGRAM.....	68
FIGURE 10-2 STORAGE NETWORK CONFIGURATION DIAGRAM	70

Clause 0 Introduction

0.1 Preamble

The SPC Benchmark-1™ (SPC-1) is a sophisticated performance measurement workload for storage subsystems. The benchmark simulates the demands placed upon on-line, non-volatile storage in a typical server-class computer system. SPC-1 provides measurements in support of real world environments characterized by:

- Demanding total I/O throughput requirements.
- Sensitive I/O response time constraints.
- Dynamic workload behaviors.
- Substantial storage capacity requirements.
- Diverse user populations and expectations.
- Data persistence requirements to ensure preservation of all committed data without corruption or loss in the event of a loss of power or storage device failure.

SPC-1 is designed as a source of comparative storage subsystem performance information. It is intended to provide value throughout the storage product lifecycle (e.g. development of product requirements; product implementation; performance tuning; capacity planning, market positioning; and purchase evaluations).

In view of the broad applicability of the SPC-1 benchmark, it is anticipated that readers may wish to approach the present document via a variety of starting points. For example:

- Readers who need only a quick overview of the benchmark itself can obtain one by examining Clause 1 (broad introduction to the benchmark environment) and Table 3-2, Table 3-3, and Table 3-4 (the I/O workload characteristics presented in tabular form).
- Readers who wish a detailed understanding of the benchmark should, in addition, consult Clause 2 (organization of storage), Clause 3 (SPC-1 workload definition) and Clause 4 (benchmark usage in specific configurations).
- Readers who are examining or referring to test results obtained by running the SPC-1 benchmark should minimally examine Clause 8 (reported data). Clause 5 and Clause 6 (execution rules) are also recommended for such readers.
- Readers who wish to actually run an SPC-1 benchmark test should minimally examine Clause 2, Clause 5, Clause 6, and Clause 7.
- Finally, readers who wish to submit SPC-1 benchmark results for posting by the SPC must read the entire SPC-1 specification to ensure compliance with its provisions.

The SPC-1 specification is intended to be vendor and platform independent. Any vendor should be able to sponsor and publish an SPC-1 benchmark, provided their tested configuration satisfies the performance, integrity, and availability requirements of the specification. Further, the benchmark is intended to be meaningful across a broad range of system configurations and storage topologies including:

- *Different storage components*: the specification allows virtually any combination of storage technologies in a system configuration. Implementers are free to use any combination of storage types and to select the level of redundancy and reliability that best showcases their solution.
- *Various interconnect topologies*: the benchmark has been designed to allow for all forms of system and network interconnection. New network-based solutions (i.e.,

SANs) and more traditional host-based systems can both produce accurate and meaningful benchmark results.

- *Varied task assignments:* SPC-1 allows vendors to optimally demonstrate the performance features of their storage solutions. In addition, and regardless of implementation choices, SPC-1 will provide a means of robust and reliable performance verification.
- *Adaptive scheduling, caching and resource allocation:* By relying on a diverse and sophisticated model of the storage workload that systems will encounter in the field, SPC-1 will provide a fair evaluation of the quality of automated performance optimization algorithms throughout the storage subsystem.

Rather than requiring or favoring a particular implementation, it is the goal of the SPC-1 benchmark specification to provide a robust, verifiable, reproducible environment within which the relative strengths of differing design and configuration approaches can be evaluated.

0.2 General Guidelines

The purpose of SPC benchmarks is to provide objective, relevant, and verifiable data to purchasers of I/O subsystems. To that end, SPC specifications require that benchmark tests be implemented with system platforms and products that:

- Are generally available to users.
- A significant percentage of the users in the target market segment (server class systems) would implement.
- Are relevant to the market segment that the benchmark represents.

In addition, all SPC benchmark results are required to be sponsored by a distinctly identifiable entity, which is referred to as the [TEST SPONSOR](#). The [TEST SPONSOR](#) is responsible for the submission of all required SPC benchmark results and materials. The [TEST SPONSOR](#) is responsible for the completeness, accuracy, and authenticity of those submitted results and materials as attested to in the required Letter of Good Faith (see Appendix A).

The use of new systems, products, technologies (hardware or software) and pricing is encouraged so long as they meet the requirements above. Specifically prohibited are benchmark systems, products, pricing (hereafter referred to as "implementations") whose primary purpose is performance optimization of SPC benchmark results without any corresponding applicability to real-world applications and environments. In other words, all "benchmark specials," implementations that improve benchmark results but not general, real-world performance, are prohibited.

The following characteristics should be used as a guide to judge whether a particular implementation is a "benchmark special". It is not required that each point below be met, but that the cumulative weight of the evidence be considered to identify an unacceptable implementation. Absolute certainty or certainty beyond a reasonable doubt is not required to make a judgment on this complex issue. The question that must be answered is this: based on the available evidence, does the clear preponderance (the greater share or weight) of evidence indicate that this implementation is a "benchmark special"?

The following characteristics should be used to judge whether a particular implementation is a benchmark special:

- Is the implementation generally available, documented, and supported?
- Does the implementation have significant restrictions on its use or applicability that limits its use beyond SPC benchmarks?
- Is the implementation or part of the implementation poorly integrated into the larger product?
- Does the implementation take special advantage of the limited nature of SPC benchmarks (e.g., I/O request profile, I/O request mix, I/O request concurrency and/or resource contention) in a manner that would not be generally applicable to the environment the benchmark represents?
- Is the use of the implementation discouraged by the vendor? (This includes failing to promote the implementation in a manner similar to the [TEST SPONSOR](#)'s other products and technologies.)
- Does the implementation require uncommon sophistication on the part of the end-user, programmer, or system administrator?
- Is the packaging or pricing unusual or non-customary for the vendor or unusual or non-customary to normal business practices? The following pricing practices are suspect:
 - Availability of a discount to a small subset of possible customers.
 - Discounts documented in an unusual or non-customary manner.
 - Pricing featured as a close-out or one-time special.
 - Unusual or non-customary restrictions on transferability of product, warranty or maintenance on discounted items.
- Is the implementation being commonly used or purchased by a majority of end-users in the market area the benchmark represents? If the implementation is not currently being used by end-users, is there any evidence to indicate that it will be used by a significant number of users?

To assure the equitable application of this standard, the SPC has created a robust system of audit and peer review. It is the goal of the SPC to assure that only those results that represent accurate and meaningful product performance will be endorsed as official SPC results.

0.3 Measurement Guidelines

SPC benchmark results are expected to be accurate representations of subsystem performance. Therefore, stringent measurement, auditing, and reporting guidelines are mandated by this specification. In general, fidelity and candor must be maintained in reporting any anomalies in the results, even if not specified in the benchmark requirements.

More detailed measurement, evaluation and disclosure requirements can be found in the body of the specification.

0.4 Related Documents

This benchmark specification relies on:

- Version 1 of the *SPC Pricing Guide*
- Version 1 of the *SPC Glossary (included as Appendix C)*

0.5 Document Conventions

This document follows the standard typographical conventions for SPC publications.

Generally, words and expressions will adhere to their common English usage. Where a particular term is being defined or assumed to have a benchmark-specific meaning, it appears in SMALLCAPS, and its formal definition can be found in the *SPC Glossary*.

0.6 Disclaimer

While this workload models a rich multi-user environment that emulates a broad range of server applications, it neither represents the entire range of I/O requirements for server systems nor precisely mimics any particular application. In addition, the extent to which anyone is capable of achieving the results reported by a vendor is highly dependent upon how closely the customer's application maps to the SPC-1 workload. The extrapolation of SPC-1 results to other environments is therefore not recommended.

Actual system performance is highly dependent upon specific workload characteristics, platform configuration, and application-specific tuning. Relative system performance will vary as a result of these and other factors. Thus, SPC-1 should not be used as a substitute for customer application benchmarking when critical performance requirements are called for.

SPC-1 uses terminology and metrics that are similar to other benchmarks. This similarity does not imply that results from this benchmark are comparable with other benchmarks.

Clause 1 Workload Environment

1.1 Business and Application Environment

SPC-1 is comprised of a set of I/O operations designed to demonstrate the performance of a storage subsystem while performing the typical functions of a business-critical application. SPC-1 represents a segment of applications characterized by predominately-random I/O operations and requiring both queries as well as update operations (for example: OLTP systems, database systems, or mail server applications).

1.2 High-Level Workload Model

1.2.1 Overview

The segment of applications represented by SPC-1 covers a broad range of user profiles, business functions and system configurations. Since the focus of SPC-1 is on the commonalities of those applications (e.g., high reliance on stored data, multi-user access, etc.), it was necessary to develop a model that would simplify the workload to the point that highlighted the similarities of its business segment while removing any conflicts and details that weren't central to performance evaluation. The model used in SPC-1 has two central scaling components:

- [STIMULUS SCALING UNITS](#) (SSUs)
- [APPLICATION STORAGE UNIT](#) (ASUs)

1.2.2 Stimulus Scaling Units (SSUs)

[STIMULUS SCALING UNITS](#) (SSUs) are a logical abstraction that captures the key elements in the IO demands of an application's user population. By focusing the benchmark on this aggregated IO load, SPC-1 is able to provide a scalable stimulus for the tested system that will provide a broad test of the storage configuration without getting lost in the detail that would be necessary for the accurate modeling of any one application. The result will be a workload that will retain its relevance across many generations of a particular application and through a broad spectrum of possible applications.

SPC-1 is scaled by increasing or decreasing the requested IO load while maintaining the precise mix of operations and constraints. At any given load level, the requested IO load is mapped to a specific number of [SSUs](#) to capture common inter-user behaviors, and the appropriate balance between application IO and logging IO.

One SPC-1 [SSU](#) corresponds to a community of users who collectively generate up to 500 I/O's per second.

1.2.3 Application Storage Units (ASUs)

In the same way that the [SSU](#) generalizes the IO load presented to a tested system by an application, [APPLICATION STORAGE UNIT](#) (ASUs) are used to abstract the storage configuration that must respond to that IO load. An [ASU](#) is the logical entity identified by the application as the destination or source of data that requires persistence beyond the execution of the application. If the [SSU](#) can be thought of as the source of the benchmark workload, then the ASU becomes the sink, providing the logical environment in which the abstracted workload is run.

An [ASU](#) represents an abstraction of storage media and does not require a particular physical implementation. The physical implementation is determined by the [TEST SPONSOR](#) and must meet the storage configuration requirements stated in Clause 2. See Clause 4 for examples of supported configurations.

Clause 2 Storage Capacity & Content

2.1 Storage Capacity Hierarchy

SPC-1 views storage capacity in terms of a three-level hierarchy, as follows:

- [PHYSICAL STORAGE CAPACITY](#)
- [LOGICAL VOLUME ADDRESSABLE CAPACITY](#)
- [APPLICATION STORAGE UNIT CAPACITY](#).

2.2 Storage Devices & Physical Storage Capacity

2.2.1 Storage Device Capacity

2.2.1.1 The storage capacity of a [STORAGE DEVICE](#) is its formatted capacity, if that information is publicly available.

2.2.1.2 In cases where the formatted capacity of a [STORAGE DEVICE](#) is not publicly available, the storage capacity will be the maximum capacity that can be made available for application use from that [STORAGE DEVICE](#).

2.2.1.3 In cases where both the formatted capacity and the capacity available for application use are publicly available information, the [TEST SPONSOR](#) shall report the formatted capacity.

Comment: *The capacity of a [STORAGE DEVICE](#), as used in computing the [PHYSICAL STORAGE CAPACITY](#), must be based on the maximum available storage capacity of the [STORAGE DEVICE](#) as configured by the manufacturer, regardless of whether it has subsequently been reconfigured to make a lesser storage capacity available for application use*

2.3 Logical Volumes

Examples of an SPC-1 [LOGICAL VOLUME](#) include, but are not limited to:

- A single physical disk drive.
- A partition on a single physical disk drive.
- Multiple disk drives configured combined in an array.
- A single logical partition on a multi-drive array.
- Multiple, non-contiguous segments of one or more physical disk drives.
- A virtual disk accessed via a Storage Area Network (SAN).
- A RAM disk.
- A hierarchy of any of the above.

2.4 Application Storage Units & ASU Capacity

2.4.1 An [APPLICATION STORAGE UNIT \(ASU\)](#) represents is a logical interface between the SPC-1 benchmark's data set and the SPC [WORKLOAD GENERATOR](#), and includes the persistent, non-volatile storage read and or written in the course of executing the benchmark.

- 2.4.2 All [LOGICAL VOLUME](#) to [ASU](#) mappings are permissible, provided they satisfy the requirements in Clauses 2.4.4 through 2.4.7. See Figure 2-1 for illustration of some example mapping examples.
- 2.4.3 Each [ASU](#) must be contained in a unique address space that is addressable by the SPC-1 [WORKLOAD GENERATOR](#) as a contiguous set of [LOGICAL BLOCKS](#).

Figure 2-1 Sample ASU- to- Logical Volume Address Mappings

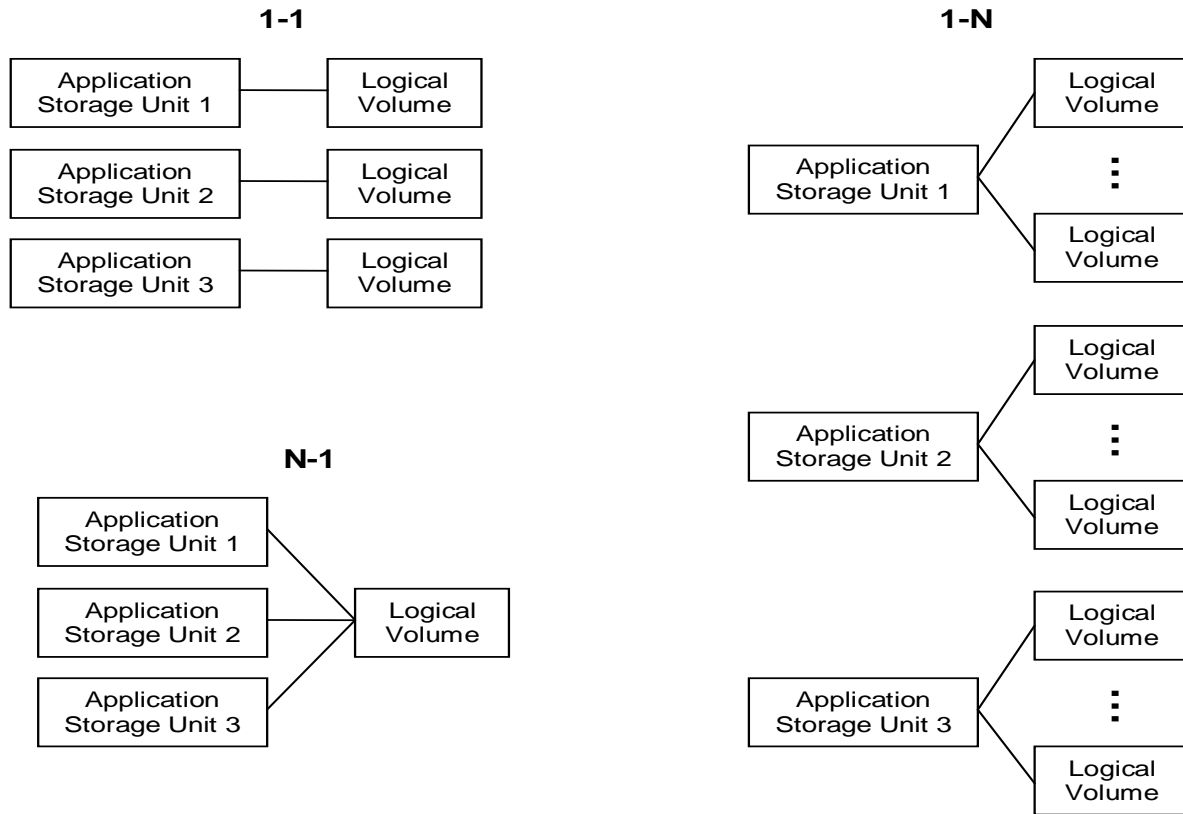

- 2.4.4 If an [ASU](#) is mapped to more than one [LOGICAL VOLUME](#), each [LOGICAL VOLUME](#) must have the same addressable capacity.
- 2.4.5 If an [ASU](#) is mapped to multiple [LOGICAL VOLUMES](#) and the storage capacity of the [ASU](#) is smaller than the total addressable capacity of those [LOGICAL VOLUMES](#), the storage capacity of the [ASU](#) shall be evenly distributed across those [LOGICAL VOLUMES](#).
- 2.4.6 If an [ASU](#) is mapped to multiple [LOGICAL VOLUMES](#), the address mapping shall be a simple concatenation of these [LOGICAL VOLUMES](#).
- 2.4.7 Any portion of the addressable capacity of a [LOGICAL VOLUME](#) to which no [ASU](#) is mapped is not included in the calculation of [ASU CAPACITY](#).

2.5 Physical Free Space

2.5.1 [PHYSICAL FREE SPACE](#) measurement excludes capacity reserved by the system and not available to hold application data or related metadata. Examples of such reserves might include spare drives, fixed metadata partitions, or capacity reserved to enable garbage collection.

Comment: [PHYSICAL FREE SPACE](#) includes writable space within the [LOGICAL VOLUMES](#) that is not consumed by each [ASU](#), as well as space that could only be used by creating additional [LOGICAL VOLUMES](#).

Comment: Space that, if written, would push the [TSC'S](#) self-reported capacity utilization above 100.0% is not part of the [PHYSICAL FREE SPACE](#).

Comment: Space that is no longer in use, but cannot be written to because the garbage collector must first run to reclaim the space is overhead, not [PHYSICAL FREE SPACE](#).

2.5.2 Physical Free Space Calculation

2.5.2.1 Assumptions

There are many space management and data protection systems in use in modern storage systems. [PHYSICAL FREE SPACE](#) will be calculated somewhat differently in each of the following examples. In each of these examples, we assume the [TSC](#) is a single array with 10 [STORAGE DEVICES](#), each with a formatted capacity of 1,000 GiB. The [TEST SPONSOR](#) is setting up the [TSC](#) to run an SPC-1 test with a 4,000 GiB [ASU CAPACITY](#).

2.5.2.2 Free space example 1

Consider an array using RAID 10 data protection with essentially no metadata overhead. This array does no space optimization and does not thin-provision volumes. The entire array has been configured into a single RAID group. This group can hold 5,000 GiB of data. The [TEST SPONSOR](#) has created 5 [LOGICAL VOLUMES](#), each 950 GiB in size. ASU-1 and ASU-2 will each consume 1,800 GiB of space spread equally across two [LOGICAL VOLUMES](#). ASU-3 will consume 400 GiB of space on the fifth [LOGICAL VOLUME](#).

This array will have 1,000 GiB of [PHYSICAL FREE SPACE](#), calculated as follows: There is 250 GiB of space in the RAID group not allocated to any [LOGICAL VOLUME](#). Each of the [LOGICAL VOLUMES](#) supporting ASU-1 and ASU-2 have 50 GiB of space not consumed by the [ASU](#). The [LOGICAL VOLUMES](#) supporting ASU-3 has 550 GiB of free space.

The total [PHYSICAL FREE SPACE](#) is 250 GiB + 4 X 50 GiB + 550 GiB = 1,000 GiB (see Figure 2-2)

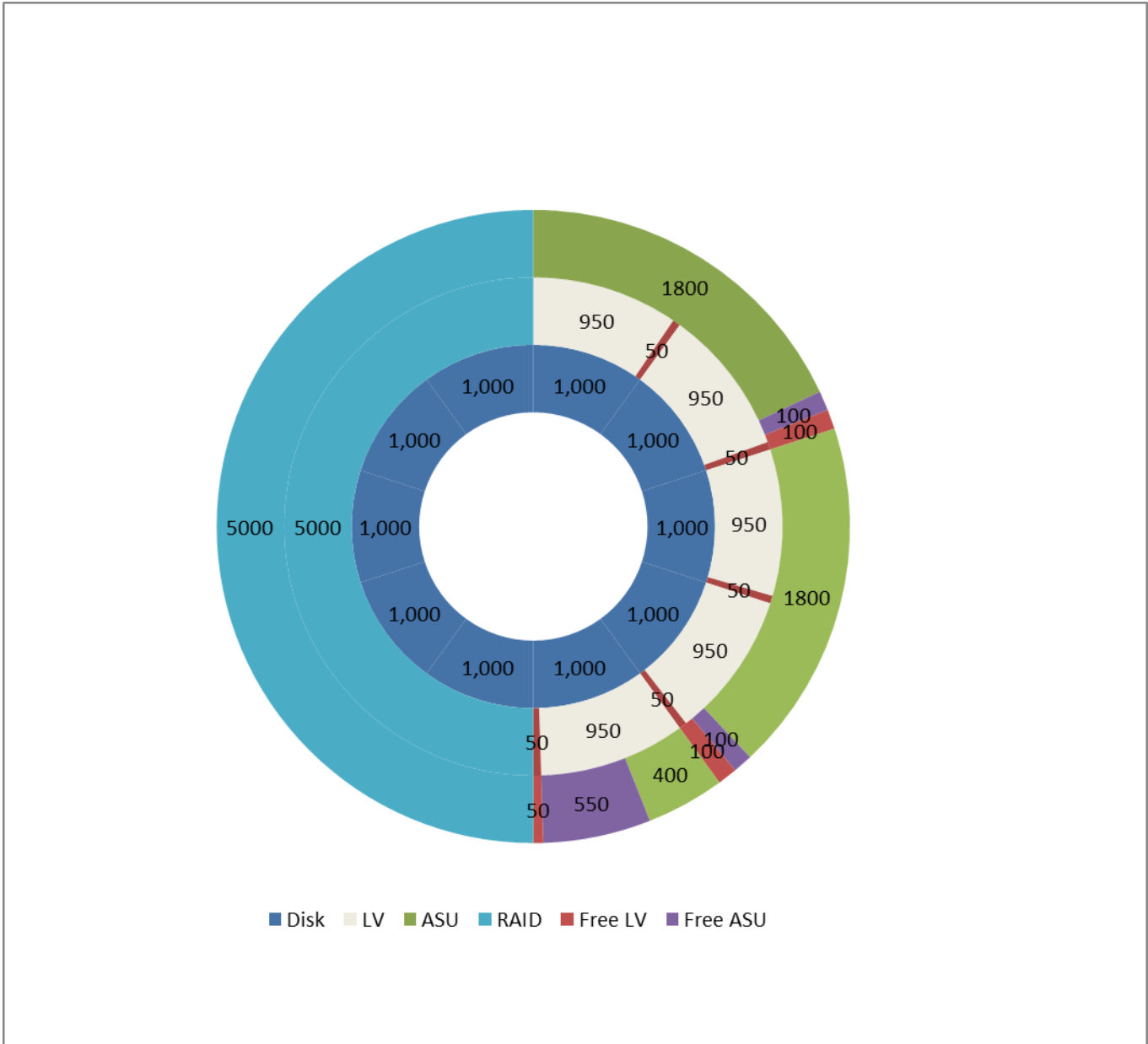

Figure 2-2 Physical Free Space: Example 1

2.5.2.3 Free space example 2

Consider an array using a single pool of space created using RAID 6 across 9 of the drives. The 10th drive is a spare. In addition, the array reserves 1 drive’s worth of physical capacity within the RAID set to allow for a rebuild after a drive failure. This array uses extensive space optimization and thin provisioning. As a result, 10% of the available space (after RAID and spare capacity overheads) is set aside for garbage collection overhead. Finally, there is a fixed 10 GiB pool of system meta-data.

The [TEST SPONSOR](#) has created 5 volumes, each 2,000 GiB in size. However these volumes are thin-provisioned and, since the [ASU](#) pre-fill phase has not been run, they consume no space.

This array will have 5,390 GiB of [PHYSICAL FREE SPACE](#), calculated as follows. Of the original 10,000 GiB of capacity:

- 2,000 GiB is consumed by RAID 6 parity,
- 1,000 GiB by the spare drive,
- 1,000 GiB by the spare capacity within the RAID group.
- 6,000 GiB of available capacity, of which:
 - 10% or 600 GiB is set aside for the garbage collector,
 - 10 GiB is set aside for system metadata.

Thus the [PHYSICAL FREE SPACE](#) is $(10,000 \text{ GiB} - 2,000 \text{ GiB} - 1,000 \text{ GiB} - 1,000 \text{ GiB}) * 0.9 - 10 \text{ GiB}$, or 5,390 GiB

2.5.2.4 Free space example 3

Continuing example 2, after the [ASU](#) pre-fill phase runs, the array reports that 1,120 GiB of physical space has been consumed by the compressed and deduplicated [ASUS](#). [PHYSICAL FREE SPACE](#) is now now 5,390 GiB - 1,120 GiB or 4,270 GiB.

2.6 ASU Content Mix

2.6.1 Overview

SPC-1 defines three type of data content:

- Sparse: Content in this category is assumed to contain sparse data where a large amount of the capacity contains all zeros (or any single value) and can be compressed to a small number of bytes (e.g., a representative value and the number of occurrences), regardless of the original file size.
- Text: content in this category is assumed to contain ASCII English text and is intended to respond to compression through common techniques.
- Binary: content in this category is assumed to contain the 8-bit random data, mimicking the binary output of a prior compression process, and to therefore not be a candidate for further compression.

2.6.2 Unless otherwise defined for a given workload, all [ASUS](#) will be filled using the data mix defined in Table 2-1.

Table 2-1 ASU Content Mix

Content Type	Percentage
Text	40
Binary	20
Sparse	40

2.7 Space Optimization

2.7.1 Advanced space optimization techniques that increase the amount of user-accessible data that may be stored in a given amount of physical storage, such as compression or deduplication, may be used in a storage configuration.

2.7.2 If an [ASU](#) employs space optimization, the functionality used must:

- Be disclosed (see 10.8.4.6);
- Provide support for general purpose optimization, and not take special advantage of the precise content employed in SPC-1;
- Apply to all data within an [ASU](#) ;
- Be transparent to the SPC [WORKLOAD GENERATOR](#), so that there is no impact on the user application level access to data stored in an [ASU](#) .

2.7.3 The space optimization techniques employed may differ from one [ASU](#) to another.

2.7.4 SPC-1 defines two metrics for space optimization:

- The [SPACE OPTIMIZATION RATIO](#) is calculated as:

$$\text{SOR} = \frac{T}{P1 - P2}$$

Where:

SOR is [SPACE OPTIMIZATION RATIO](#)

T is total [ASU CAPACITY](#)

P1 is [PHYSICAL FREE SPACE](#) after [LOGICAL VOLUMES](#) creation

P2 is [PHYSICAL FREE SPACE](#) after Repeatability [TEST PHASE](#)

- The [SPACE EFFECTIVENESS RATIO](#) measures the ratio of the total amount SPC-1 data that the [TSC](#) can hold to the total physical capacity of the [TSC](#) . This ratio is calculated as:

$$\text{SER} = \frac{P1 * \text{SOR}}{S}$$

Where:

SER is [SPACE EFFECTIVENESS RATIO](#)

P1 is [PHYSICAL FREE SPACE](#) after [LOGICAL VOLUMES](#) creation

SOR is [SPACE OPTIMIZATION RATIO](#)

S is total [PHYSICAL STORAGE CAPACITY](#)

2.8 Data Protection and Data Access

2.8.1 A compliant [TSC](#) shall protect against loss of data due to single component failure.

2.8.2 Data protection is required for the benchmark's data repository. Data protection is categorized as one of the following data protection levels:

- [PROTECTED 1](#)
- [PROTECTED 2](#).

2.8.3 The [TEST SPONSOR](#) shall select one of the a data protection levels defined in 2.8.2, and configure the [TSC](#) to provide the selected level of data protection.

2.9 Physical Capacity Utilization

[PHYSICAL CAPACITY UTILIZATION](#) shall not be less than 35%.

Clause 3 Workload and I/O Operation Profile

3.1 Overview

SPC-1 defines several distinct workload components, layered from highest to lowest level as follows:

- [WORKLOAD](#): a collection of [ASU STREAMS](#)
- [ASU STREAM](#): a collection of [I/O STREAMS](#).
- [I/O STREAM](#): a single, well-defined, sequence of [I/O REQUESTS](#).
- [I/O REQUEST](#) or [I/O COMMAND](#): a single atomic unit of work to an [APPLICATION STORAGE UNIT](#).

The components and their relationship are illustrated in Figure 3-1.

Figure 3-1 Workload Components

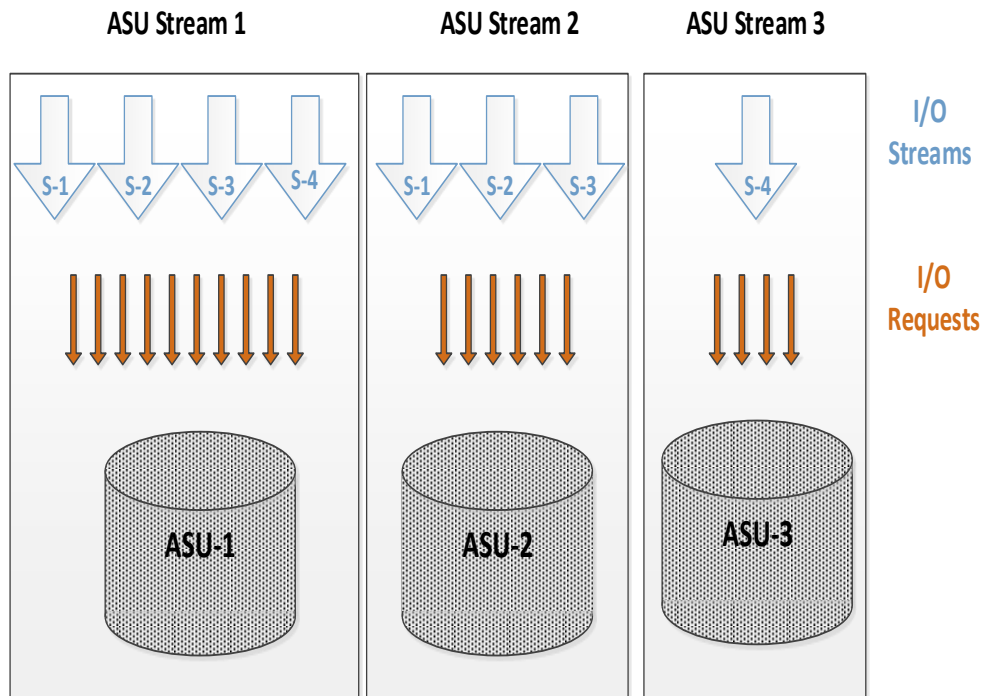

3.2 I/O Stream

3.2.1 The I/O STREAM is initiated at a specific point during the [WORKLOAD](#) execution, and has a specific lifespan.

3.2.2 The sequence of individual commands within the [I/O STREAM](#) is fully defined by the parameter settings defined for the [WORKLOAD](#) .

3.2.3 One definition is required for each [I/O STREAM](#) contained in the [WORKLOAD](#) , and is sufficient to characterize every I/O associated with that [I/O STREAM](#) .

3.3 I/O Command or I/O Request

An [I/O REQUEST](#) (or [I/O COMMAND](#)) is the lowest level in the SPC-1 workload hierarchy. It completely defines a single command that transfers data to or from an [APPLICATION STORAGE UNIT](#). It is an entity that contains sufficient information to enable the SPC-1 [WORKLOAD GENERATOR](#) to issue an I/O operation to the [APPLICATION STORAGE UNIT](#) in conformance with the SPC-1 [WORKLOAD](#) .

As an example, an [I/O REQUEST](#) might contain the following items:

- [ASU](#) identifier.
- The starting address of the data transfer.
- The byte count of the data transfer.
- The type of data transfer (read or write).
- A pointer to a buffer for transmission (writes) or reception (reads) of data.

3.4 Definitions

3.4.1 Rationale

Although many parameters associated with an I/O workload are self-explanatory, there are several that are subject to interpretation, particularly when the intent of SPC-1 is to support multiple operating systems and hardware platforms. For this reason, some preliminary definitions are needed to avoid ambiguity and/or confusion. It should be noted that the scope of these definitions is limited to SPC-1.

3.4.2 Logical Block

3.4.2.1 For SPC-1, a [LOGICAL BLOCK](#) is assumed to be 512 bytes in size.

3.4.2.2 The [I/O STREAM](#) definitions are such that hardware that only supports a 4,096-byte [LOGICAL BLOCK](#) can execute the workload successfully.

3.4.2.3 For an [ASU](#) with a block size of b and a capacity of n [LOGICAL BLOCKS](#), the capacity in bytes is equal to the product of b and n .

3.4.3 Logical Block Address (LBA)

The logical block address (LBA), which is sometime known as the logical block number (LBN), specifies the absolute address of a [LOGICAL BLOCK](#) on an [ASU](#). For an [ASU](#) with a capacity of n [LOGICAL BLOCKS](#) , it is a discrete value that ranges from a value of 0 (zero) for the first [LOGICAL BLOCK](#) on the [ASU](#) to a high of $n-1$ for the last [LOGICAL BLOCK](#) on the [ASU](#).

3.4.4 Measurement Units

3.4.4.1 “Decimal” (powers of ten) Measurement Units

In the storage industry, the terms “kilo”, “mega”, “giga”, “tera”, peta, and “exa” are commonly used prefixes for computing performance and capacity. For the purposes of the SPC-1 [WORKLOAD](#), all of these terms are defined in powers of 10. Specifically:

- A kilobyte (KB) is equal to 1,000 (10^3) bytes.
- A megabyte (MB) is equal to 1,000,000 (10^6) bytes.
- A gigabyte (GB) is equal to 1,000,000,000 (10^9) bytes.
- A terabyte (TB) is equal to 1,000,000,000,000 (10^{12}) bytes.
- A petabyte (PB) is equal to 1,000,000,000,000,000 (10^{15}) bytes.
- An exabyte (EB) is equal to 1,000,000,000,000,000,000 (10^{18}) bytes.

3.4.4.2 “Binary” (powers of two) Measurement Units

The sizes reported by many operating system components use “power of two” measurements units rather than “power of ten” units. The following standardized definitions and terms are also valid and may be used in this specification.

- A kibibyte (KiB) is equal to 1,024 (2^{10}) bytes.
- A mebibyte (MiB) is equal to 1,048,576 (2^{20}) bytes.
- A gibibyte (GiB) is equal to 1,073,741,824 (2^{30}) bytes.
- A tebibyte (TiB) is equal to 1,099,511,627,776 (2^{40}) bytes.
- A pebibyte (PiB) is equal to 1,125,899,906,842,624 (2^{50}) bytes.
- An exbibyte (EiB) is equal to 1,152,921,504,606,846,967 (2^{60}) bytes.

3.5 SPC-1 Parameter Types

3.5.1 Integer

An integer parameter is capable of storing discrete, signed values. The range is operating system and/or compiler dependent, but must be a minimum of 32 bits, including the sign bit (-2,147,483,648 to 2,147,483,647).

3.5.2 Long Integer

A long integer parameter is capable of storing discrete, signed values. The range is operating system and/or compiler dependent, but must be a minimum of 64 bits, including the sign bit (-9,223,372,036,854,775,808 to 9,223,372,036,854,775,807).

3.5.3 Real

A real parameter is capable of storing positive and negative continuous values. The range is operating system and/or compiler dependent, but must have a minimum range of from -10^{-32} to 10^{32} with a minimum resolution of 16 significant digits.

3.5.4 ASCII string

An ASCII string parameter consists of a variable length sequence of ASCII characters (8 bits per character), with a zero byte terminating the string.

3.5.5 Distribution

The distribution is a special data type that has been implemented specifically for the SPC parameter list. This data type contains sufficient information to characterize a distribution that may be used for certain parameters. This data type consists of several components.

3.5.5.1 Distribution type

The type of distribution is indicated by an integer variable. The legal types of distributions are:

0. Constant – A single number. The value of this number is contained in the first element of the distribution parameter list.
1. Uniform – A number that is uniformly distributed between (and including) two values. The lower of these values is contained in the first element of the distribution parameter list, and the upper value is contained in the second element.
2. Exponential – A number that is exponentially distributed with a mean value contained in the first element of the distribution parameter list.
3. Table – A table distribution is an n-dimensional array containing the discrete table values. There is no limit on the number of dimensions or entries in the array. The pointer component (section) of the distribution data type points to the start of the array. The contents of the array are undefined, and must be specified for each case.
4. Incremental: An ascending series of values. This distribution has four associated parameters, incremental (start, startvar, stride, length).

The first parameter “start”, which is required, defines the first value of a monotonically increasing sequence. “start” is a real number [0,1] representing the mean of the location within the [ASU](#) address range that the sequence begins, given as a fraction of the total address range, and modified by the “startvar” parameter. The sequence will increase to the highest possible value, and then begin again at a new first value, repeating.

The second parameter “startvar”, which is optional, is a real number [0,1] representing the fraction of the total [ASU](#) extent through which the “start” value can be varied. If “startvar” is zero, the “start” value is always used when the first [ASU](#) address is required in a sequence. If “startvar” is nonzero, a new first value is computed each time the lowest [ASU](#) address is required, and is computed as a uniformly distributed random number within \pm startvar/2 of the mean, “start”. If “start+startvar/2” is > 1 , the value of 1 will be used for the upper limit of the first value in a sequence. If “start - startvar/2” is ≤ 0 , the value of 0 will be used for the lower limit of the first value of a sequence. If “startvar” is not present, its value is assumed to be zero.

The third parameter, “stride”, which is optional, defines the gap between values in the series. “stride” is an integer representing the number of blocks between each value in the series. Since I/O transfer size is variable, even within a stream, “stride” must be related to the I/O size. A “stride” of zero is used to generate a sequence of values in which the next value = old value + transfer size. If “stride” is not supplied, a value of zero is assumed. A “stride > 0 implies the new value = old value + transfer size + stride. A stride < 0 is always interpreted as a sequence of I/Os in which the address is always the same.

The fourth parameter, “length” which is optional, is used to define the upper extent of the generated sequence. “length” is a real number (0,1] representing the fraction of the total address space over which the sequence is generated, relative to the first value of the sequence. “length” is added to each new computed first value to determine the upper extent of the series. If “length” is not present, the sequence will be generated from its start value, up to 1, and then will repeat beginning at the new start value.

For example, incremental (0.35, 0.7, 8, 0.3) will generate a sequence with start address at 35% of the total address space, $\pm 35\%$. The sequence will have a gap of (8 blocks + transfer size) between each I/O start address. The highest address generated will be 30% of the total address space higher than the first value, or at 70% of the total address space if the first value is at 40%. The sequence will continue until the stream is terminated through other means.

5. Random access pattern R1 – A random walk with “hierarchical reuse” behavior (see Appendix E), using a leaf size of 65536 bytes and parameters $k=6$, $v=.44$. Upon the first read to a given leaf, the first 8192-byte block is read from that leaf. Subsequent reads to the leaf read the second block, the third block, and so on, wrapping back to the first block after reading the last. (Note: if multiple, logically distinct random walks are occurring concurrently within the same [ASU](#), the first and subsequent reads to a given leaf are implemented as just described, regardless of whether they are associated with the same or with logically distinct random walks). (see Clause 3.6.3.4)
6. Random access pattern W1 – Also a random walk with “hierarchical reuse” behavior, using a leaf size of 65536 bytes and parameters $k=6$, $v=.44$. The leaf L_0 initially selected in this manner, however, is then used to obtain the final leaf selection $L = 8 * \text{Floor}(L_0/8)$. Within the selected leaf, the 8192-byte block to be written is determined as follows. With 50 percent probability, the 8192-byte block is chosen using a random uniform distribution across all blocks of this size contained in the leaf. With the remaining 50 percent probability, the most recently read block is chosen. Once the full address of the write operation is obtained, as just described, then with an 85 percent probability, a single write is performed to the selected address. With the remaining 15 percent probability, *two* writes are performed to this address (that is, an exception occurs to the random walk scheme, in that no step is taken prior to the second write of the pair). (see Clause 3.6.3.4)

As new distributions become necessary, they will be added to this list in a monotonically increasing sequence.

3.5.5.2 Result type

The result type indicates whether the resulting value from the distribution is integer or real. There are three possible values for this field:

1. Integer – The output of the distribution is an integer.
2. Long - The output of the distribution is a long integer.
3. Real – The output of the distribution is a real number.

3.5.5.3 Distribution parameter list

The distribution parameters consist of a list of ten real numbers. The values contained in these fields may be used as part of the distribution function. The number of values that are used is function dependent, and may range from none to all ten.

3.5.5.4 Extended pointer

The extended pointer is used when it is necessary to include more than ten discrete parameters or when a singly dimensioned list is not adequate. The primary use of this pointer is when a table distribution is required. The data structure that is pointed to by this element is not defined by this document.

3.6 SPC-1 Workload Parameters

3.6.1 Overview

A set of parameters is required for each IO STREAM that is present in the SPC-1 [WORKLOAD](#). These parameters are passed to the SPC-1 [WORKLOAD GENERATOR](#). The set of parameters will enable the SPC-1 [WORKLOAD GENERATOR](#) to create and submit a stream of individual [I/O REQUESTS](#) to the [APPLICATION STORAGE UNIT](#).

Conceptually, the SPC-1 [WORKLOAD GENERATOR](#) will examine the parameters, and by using the values contained in these parameters, generate a sequence of [I/O REQUESTS](#), with each individual command being issued at the appropriate time. All SPC workload parameters are present, but may not be applicable.

3.6.2 Transfer Alignment

3.6.2.1 Description

The transfer alignment parameter determines whether the starting I/O address is aligned to any specific quantity. It is intended primarily for use with random accesses within a small range. This is due to the common practice of applications to only access data on certain address boundaries, such as database block size, page size, etc. In essence, this is a modulus operator that will, after a starting address has been determined, force that address to modulo n , where n is the transfer alignment parameter, in blocks.

3.6.2.2 Parameter type

The transfer alignment parameter is an integer variable.

3.6.2.3 Acceptable values

The transfer alignment parameter may take on any positive value greater than or equal to zero. The upper limit is set by media size and/or integer length. If the value of this parameter is zero, then transfer alignment is disabled. If this parameter contains a non-zero value (n), then all transfer requests will be performed modulo n .

3.6.3 Stimulus Group

3.6.3.1 Description

Generally, [I/O STREAMS](#) work in isolation from one another. Some of the access patterns defined for the SPC-1 [WORKLOAD](#) (e.g., R1 or W1) require [I/O STREAMS](#) to interact to produce a required stimulus. The stimulus group parameter defines the number of instances of a given [I/O STREAM](#) that will work collectively to produce the required stimulus.

3.6.3.2 Parameter type

The stimulus group parameter is an integer variable.

3.6.3.3 Acceptable values

The stimulus group parameter may take on any positive value greater than or equal to 1. If the value of this parameter is 1, each instance of the defined [I/O STREAMS](#) operates in isolation. If this parameter contains a value greater than 1, such as n , then each n instances of the defined [I/O STREAM](#) will share a common state or context.

For SPC-1, where [I/O STREAM](#) definitions require collaboration between [I/O STREAMS](#) (i.e., data re-reference), each group of 100 [SSUS](#) will work together.

3.6.3.4 Data Re-reference

Data re-referencing occurs when an I/O references data that has been referenced previously. This allows those I/O STREAMS that would benefit from a random-access cache to realize those benefits by having the I/O STREAMS perform the appropriate accesses.

In the SPC-1 benchmark, data re-reference is specified by applying an appropriate distribution to the selection of reference addresses. More specifically, certain [I/O STREAMS](#) of the SPC-1 benchmark, as specified in Clause 3.7, select the next transfer address by performing a random walk. The sequence of addresses visited in the random walk includes both those where reads are performed, and those where writes are performed. The next step of the random walk is computed, based upon the most recent visit location, by applying distribution R1 when it is intended to perform a read, and distribution W1 when it is intended to perform a write.

3.6.4 Intensity Multiplier

3.6.4.1 Description

The [INTENSITY MULTIPLIER](#) parameter indicates the ratio of the traffic intensity of this [I/O STREAM](#) relative to the total traffic intensity of all [I/O STREAMS](#).

3.6.4.2 Parameter type

The [INTENSITY MULTIPLIER](#) parameter is a real (floating-point) variable.

3.6.4.3 Acceptable values

The [INTENSITY MULTIPLIER](#) parameter may take on all positive values, including zero.

3.6.5 **Memory Alignment**

3.6.5.1 Description

The memory alignment parameter allows the data sent and received from an I/O operation to be placed in host computer memory on certain byte boundaries.

3.6.5.2 Parameter type

The memory alignment parameter is an integer variable specifying the byte alignment.

3.6.5.3 Acceptable values

The memory alignment parameter may take on any positive value greater than or equal to zero, although the most common cases will specify a power of 2. There are two cases:

- A value of zero indicates that memory alignment is disabled.
- A value of n indicates that all data transfers to and from memory will begin at a memory address that is evenly divisible by n bytes. As an example, in order to force quadword (64 bit) alignment, this parameter must be set to 8.

3.6.6 **Model Type**

3.6.6.1 Description

The model type parameter indicates whether the [I/O STREAM](#) follows an open or closed model.

3.6.6.2 Parameter type

The model type parameter is an integer variable.

3.6.6.3 Acceptable values

The model type parameter may take on one of the following values representing the workload type:

- Open
- Closed

3.6.7 **Population**

3.6.7.1 Description

The population parameter specifies the number of active instances of this I/O STREAM definition included within an [ASU STREAM](#).

3.6.7.2 Parameter type

The population parameter is an integer variable.

3.6.7.3

Acceptable values

Each [I/O STREAM](#) of the SPC-1 [WORKLOAD](#) has a population of 1.

3.6.8

Read Fraction

3.6.8.1

Description

The read fraction parameter specifies the fraction of [I/O REQUESTS](#) that are reads.

3.6.8.2

Parameter type

The read fraction parameter is a distribution of real (floating-point) variables.

3.6.8.3

Acceptable values

The read fraction parameter may take on any positive real (floating point) value greater than or equal to zero and less than or equal to one.

3.6.9

Stream Identifier

3.6.9.1

Description

The stream identifier parameter, which is assigned by the SPC, is a value that uniquely identifies an [I/O STREAM](#) within a specific workload. The purpose of this parameter is to allow analysis programs to extract performance data for a specific [I/O STREAM](#) from a workload. Note that this value needs only to be unique within a [WORKLOAD](#); it is not required to be unique across all [WORKLOADS](#).

3.6.9.2

Parameter type

This parameter is a variable length ASCII string.

3.6.9.3

Acceptable values

No restriction is placed on this parameter.

3.6.10

Transfer Address

3.6.10.1

Description

The transfer address parameter determines the target address of the next I/O that will be issued to the [ASU](#).

3.6.10.2

Parameter type

The transfer address parameter is a distribution variable.

3.6.10.3

Acceptable values

The transfer address value must be greater than or equal to zero, and the sum of the transfer address and the transfer size must be less than or equal the capacity of the [ASU](#).

3.6.11 Transfer Size

3.6.11.1 Description

The transfer size parameter specifies the number of [LOGICAL BLOCKs](#) to transfer.

3.6.11.2 Parameter type

The transfer size parameter is a long integer variable, except in the SMIX case defined in 3.6.11.3.

3.6.11.3 Acceptable values

Most [I/O STREAMS](#) use a transfer size specified as a positive integer constant. Other [I/O STREAMS](#) are defined with a value of SMIX, and use the distribution defined in Table 3-1 to randomly select a transfer size for each IO operation.

Table 3-1 SMIX Transfer Size Distribution

Transfer Size (blocks)	Probability
8	40%
16	24%
32	20%
64	8%
128	8%

3.6.12 Workload Identifier

3.6.12.1 Description

The workload identifier, which is common to all I/O streams in the workload, is a unique value assigned by the SPC to identify a specific workload. The purpose of this parameter is to allow an analysis program to extract performance information for a specific workload from a test that includes more than one workload.

3.6.12.2 Parameter type

This parameter is a variable length ASCII string.

3.6.12.3 Acceptable values

No restriction is placed on this parameter.

3.7 Detailed Workload Description

3.7.1 Overview

SPC-1 is designed to demonstrate the performance of a storage system or storage components while performing the typical functions of a business application. SPC-1 represents a segment of applications characterized by predominately random I/O

operations as typified by a mail server application but not limited to that specific application type.

The storage for the SPC-1 WORKLOAD consists of three [APPLICATION STORAGE UNIT](#)s:

- ASU-1: Data Store
- ASU-2: User Store
- ASU-3: Log/Sequential Write

Each [ASU](#) is the target of an [ASU STREAMS](#) that in turn is comprised of one or more distinct I/O STREAMS. The I/O STREAMS for each [ASU](#) are defined below by a set of parameters and parameter values.

Definitions and descriptions of each parameter type used to define the SPC-1 parameters may be found in Clause 3.6. Each SPC-1 parameter is defined and described in Clause 3.7.

3.7.2 ASU- 1: Data Store

3.7.2.1 Description

The Data Store (ASU-1) holds raw incoming data for the application system. As the application system processes the data it may temporarily remain in the data store, be transferred to the user store, or be deleted.

3.7.2.2 Stream Definitions

The Data Store has four parallel [I/O STREAMS](#) associated with it. There is a read and write stream that is uniformly distributed over the entire address space, as well as some highly localized I/O to specific areas of the [ASU](#). Additionally, there is a sequential read stream present. The I/O intensity for this ASU STREAM represents 59.6% of the total SPC-1 [I/O REQUEST](#) traffic.

Table 3-2 ASU 1 Parameter Types and Values

Parameter Type	I/O Stream 1	I/O Stream 2	I/O Stream 3	I/O Stream 4
ASU	1	1	1	1
Transfer alignment (512 byte blocks)	16	16	16	16
Stimulus group	1	100	1	100
Intensity multiplier	0.035	0.281	0.070	0.210
Memory alignment	16	16	16	16
Model type	Open	Open	Open	Open
Population	1	1	1	1
Read fraction	0.5	0.5	1.0	0.5
Stream identifier	"ASU 1-1"	ASU 1-2"	"ASU 1-3"	"ASU 1-4"
Transfer address	Uniform: 0.0 – 1.0	R1/W1: 0.15 – 0.2	Incremental (0.4, 0.4, 0, 0.1)	R1/W1: 0.7 – 0.75
Transfer size (512 byte blocks)	16	16	SMIX	16
Workload identifier	"SPC-1.30"	"SPC-1.30"	"SPC-1.30"	"SPC-1.30"

3.7.2.3 I/O Content

All write operations generated for this [ASU STREAM](#) will write from a buffer that has been uniquely generated content that matches one of the content types defined for SPC-1 (see 2.6). In aggregate, write operations generated for this [ASU STREAM](#) shall match the content mix defined in Table 2-1.

3.7.2.4 Capacity

ASU-1 will hold 45.0% (+-0.5%) of the [ASU CAPACITY](#).

3.7.3 ASU-2: User Store

3.7.3.1 Description

The User Store (ASU-2) holds information processed by the application system and is stored in a self-consistent, secure, and organized state. The information is principally obtained from the data store, but may also consist of information created by the application or its users in the course of processing.

3.7.3.2 Stream Definitions

There are three parallel [I/O STREAMS](#) associated with ASU-2. Similar to the ASU-1, the User Store also has read write streams that are randomly distributed across the entire address space of the [ASU](#). There are also localized [I/O STREAMS](#), although there are fewer of these than are present on the Data Store. The I/O intensity for this [ASU STREAM](#) represents 12.3% of the total SPC-1 [I/O REQUEST](#) traffic.

Table 3-3 ASU 2 Parameter Types and Values

Parameter Type	I/O Stream 1	I/O Stream 2	I/O Stream 3
ASU	2	2	2
Transfer alignment (512 byte blocks)	16	16	16
Stimulus group	1	100	1
Intensity multiplier	0.018	0.070	0.035
Memory alignment	16	16	16
Model type	Open	Open	Open
Population	1	1	1
Read fraction	0.3	0.3	1.0
Stream identifier	"ASU 2-1"	"ASU 2-2"	"ASU 2-3"
Transfer address	Uniform: 0.0 – 1.0	R1/W1: 0.47 – 0.52	Incremental (0.4, 0.4, 0, 0.1)
Transfer size (512 byte blocks)	16	16	SMIX
Workload identifier	"SPC-1.30"	"SPC-1.30"	"SPC1.30"

3.7.3.3 I/O Content

All write operations generated for this this [ASU STREAM](#) will write from a buffer that has been uniquely generated content that matches one of the content types defined for SPC-

1 (see 2.6). In aggregate, write operations generated for this ASU STREAM shall match the content mix defined in Table 2-1.

3.7.3.4 Capacity

ASU-2 will hold 45.0% (+-0.5%) of the [ASU CAPACITY](#).

3.7.4 ASU-3: Log/Sequential Write

3.7.4.1 Description

The Log (ASU-3) contains files written by the application system for the purpose of protecting the integrity of data and information the application system maintains in the Data and User stores.

3.7.4.2 Stream Definitions

This stream represents logging and other sequential write activity. The I/O intensity for this [ASU STREAM](#) accounts for 28.1% of the total SPC-1 [I/O REQUEST](#) traffic.

Table 3-4 ASU 3 Parameter Types and Values

Parameter Type	I/O Stream 1
ASU	3
Transfer alignment (512 byte blocks)	16
Stimulus group	1
Intensity multiplier	0.281
Memory alignment	16
Model type	Open
Population	1
Read fraction	0.0
Stream identifier	"ASU 3-1"
Transfer address	Incremental (0.35, 0.7, 0, 0.3)
Transfer size (512 byte blocks)	SMIX
Workload identifier	"SPC-1.30"

3.7.4.3 I/O Content

All write operations generated for this ASU STREAM will write from a buffer that has been uniquely generated content that matches one of the content types defined for SPC-1 (see 2.6). In aggregate, write operations generated for this ASU STREAM shall match the content mix defined in Table 2-1.

3.7.4.4 Capacity

ASU-3 will hold 10.0% (+-0.5%) of the [ASU CAPACITY](#).

Clause 4 Benchmark Configuration & Tested Storage Configuration

4.1 Component Availability and Support

All hardware and software used in the [BENCHMARK CONFIGURATION](#) shall conform to the availability requirement in version 1.0 of the *SPC Pricing Guide*.

4.2 Benchmark Configuration Components

4.2.1 Host System

4.2.1.1 An SPC-1 [HOST SYSTEM](#) is responsible for organizing and managing the underlying [LOGICAL VOLUME](#)s used to implement the [ASU](#)s.

4.2.1.2 The [HOST SYSTEM](#)(s), shall not cache or buffer any data associated with implementing the [ASU](#)s on the [BC](#) nor be used to cache or buffer any [ASU](#) data.

Figure 4-1 Sample Benchmark Configurations: Direct Attach Storage

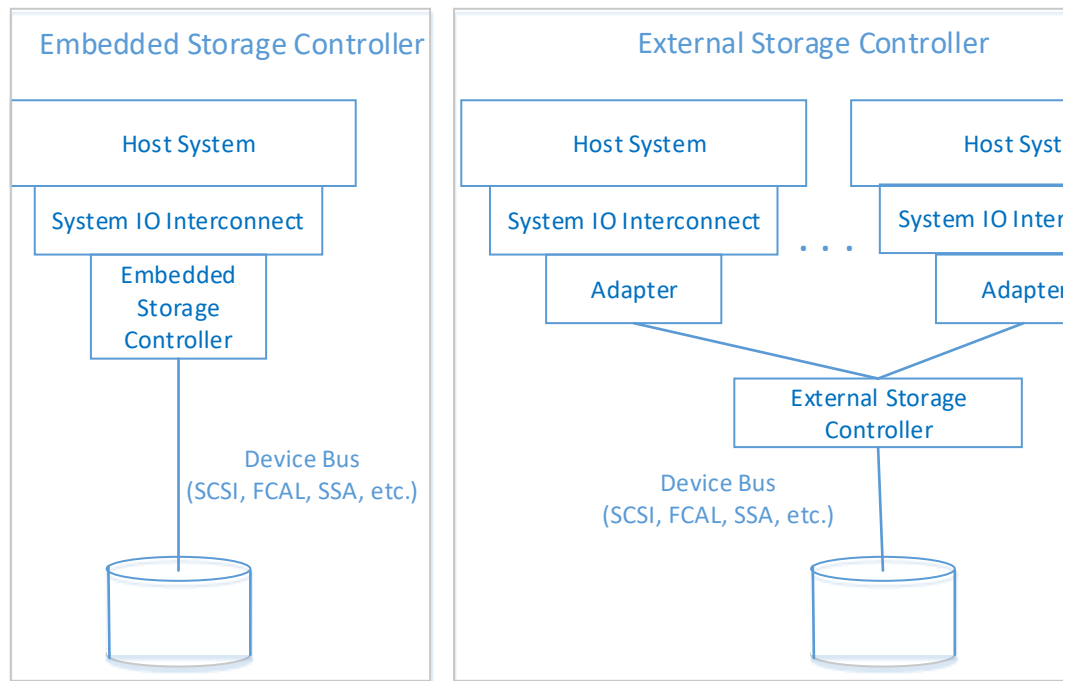

4.3 Benchmark Configuration Examples

[TEST SPONSOR](#)s may utilize a wide range of [BENCHMARK CONFIGURATIONS](#). The diagrams in Figure 4-1 and Figure 4-2 are examples of acceptable [BENCHMARK CONFIGURATIONS](#), but should not be considered as the only valid [BENCHMARK CONFIGURATIONS](#).

A [TEST SPONSOR](#) may utilize a configuration that is different from the provided examples. In such a case, the [TEST SPONSOR](#) is encouraged to contact the SPC prior to engaging in

Figure 4-2 External Storage Configurations

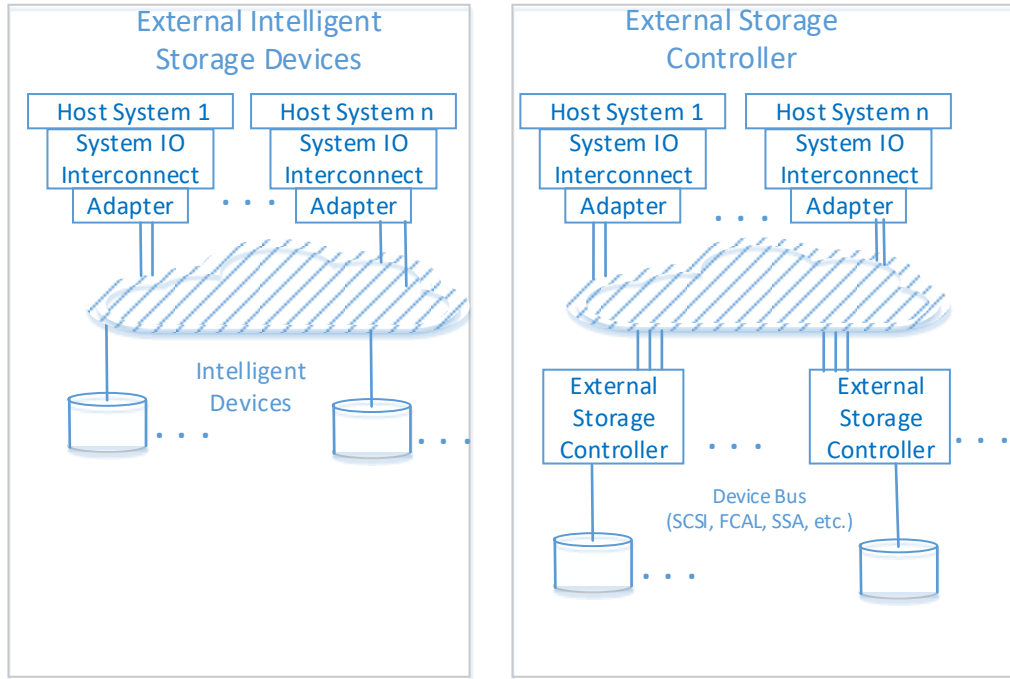

an audit to ensure the proposed configuration will meet the SPC benchmark requirements.

4.4 Tested Storage Configuration Components

4.4.1 Host System Inclusion

[HOST SYSTEM](#) inclusion in the [PRICED STORAGE CONFIGURATION](#) is defined in the *SPC Pricing Guide*.

4.4.2 Multiple Storage Subsystem Configurations

A [TEST SPONSOR](#) may choose to configure multiple, physically distinct storage subsystems in a [BENCHMARK CONFIGURATION](#). In such a case, the [TSC](#) must provide a logically cohesive storage solution. In particular, its architecture must include a recognizable layer or component that unifies the response to [I/O REQUESTS](#) such that any portion of the storage can be accessed by any given request regardless of the physical origin of the request.

Comment: *it is the intent of this clause to forbid the use of multiple functionally-independent storage products in the same [TSC](#), if they are not tied together by an architectural layer as just described.*

4.4.3 Tested Storage Configuration Examples

Clauses 4.4.4-4.4.6 describe and illustrate several typical [TESTED STORAGE CONFIGURATIONS](#), including the boundary between the [HOST SYSTEM](#) and [TSC \(TSC BOUNDARY\)](#). Those examples should not be considered the only valid [TESTED STORAGE CONFIGURATIONS](#).

A [TEST SPONSOR](#) may utilize a configuration that is different from the examples provided. In such a case, the [TEST SPONSOR](#) is encouraged to contact the SPC prior to engaging in an [AUDIT](#) to ensure the proposed configuration will meet the SPC benchmark requirements.

Figure 4-3 Embedded or External Controller – External Storage Devices

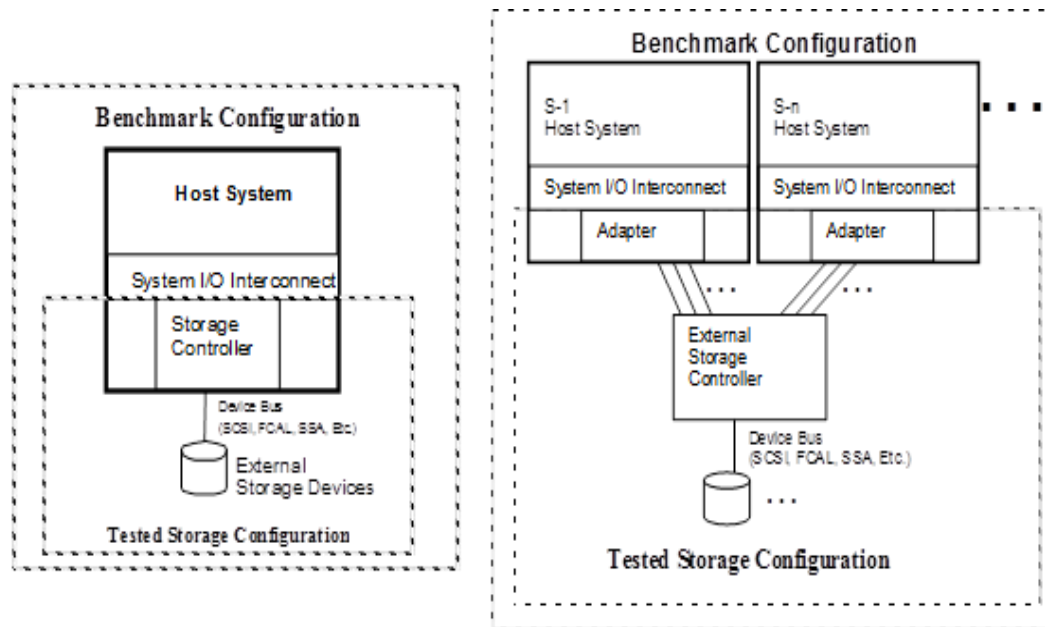

4.4.4 Embedded or External Storage Controller – External Storage Devices

Figure 4-3 illustrates two [BENCHMARK CONFIGURATIONS](#). The first [BC](#) includes a [TESTED STORAGE CONFIGURATION](#) comprised of an embedded storage controller and external [STORAGE DEVICES](#). The second [BC](#) includes a [TSC](#) comprised of an external storage controller and external [STORAGE DEVICES](#).

The components that comprise the [TSC](#) typically include:

- A storage controller that plugs into a system I/O interconnect on the [HOST SYSTEM](#)
- Batteries used to maintain power to cache/memory in the storage controller in the event of unexpected power failure.
- Cabling between the storage controller and the [STORAGE DEVICES](#) used to implement the [ASUs](#).
- All cabinetry used to house components of the [TSC](#) (excluding the cabinetry, cooling, power, and monitoring systems required to house the storage controller embedded in the [HOST SYSTEM](#) cabinet).

- Environmental monitoring systems and related cabling used to monitor the health of components of the [TSC](#).
- Fans used to cool components of the [TSC](#).
- Power supplies and related cabling used to power components of the [TSC](#).
- Power distribution systems and related cabling in cabinetry used to route power to the individual component power supplies in the [TSC](#).
- All management software necessary to present the [ASUs](#) to the SPC-1 [WORKLOAD GENERATOR](#).
- [STORAGE DEVICES](#) to provide the various levels of storage described in Clause 2.

Figure 4-4 Embedded Storage Controller – Embedded Storage Devices

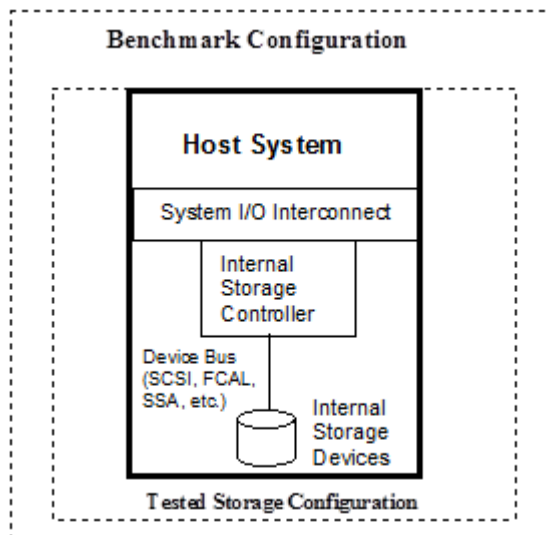

4.4.5 **Embedded Storage Controller – Embedded Storage Devices**

A [TSC](#) that utilizes [HOST SYSTEM](#) components is illustrated in Figure 4-4.

The components that comprise the [TSC](#) typically include:

- A storage controller that either plugs into a system I/O interconnect on the [HOST SYSTEM](#) or is an integral [HOST SYSTEM](#) component.
- Batteries used to maintain power to cache/memory in the storage controller in the event of unexpected power failure.
- [STORAGE DEVICES](#) to provide the various levels of storage described in Clause 2. The [STORAGE DEVICES](#) may either be connected externally to the [HOST SYSTEM](#) or connected internally as an integral [HOST SYSTEM](#) component.
- Cabling between the storage controller and the [STORAGE DEVICES](#) used to implement the [ASUs](#).
- All cabinetry used to house components of the [TSC](#).
- Environmental monitoring systems and related cabling used to monitor the health of components of the [TSC](#).
- Fans used to cool components of the [TSC](#).
- Power supplies and related cabling used to power components of the [TSC](#).

- Power distribution systems and related cabling in cabinetry used to route power to the individual component power supplies in the [TSC](#).
- All management software necessary to present the [ASUs](#) to the SPC-1 [WORKLOAD GENERATOR](#).

Figure 4-5 Network Storage –External Storage Controller and Storage Devices

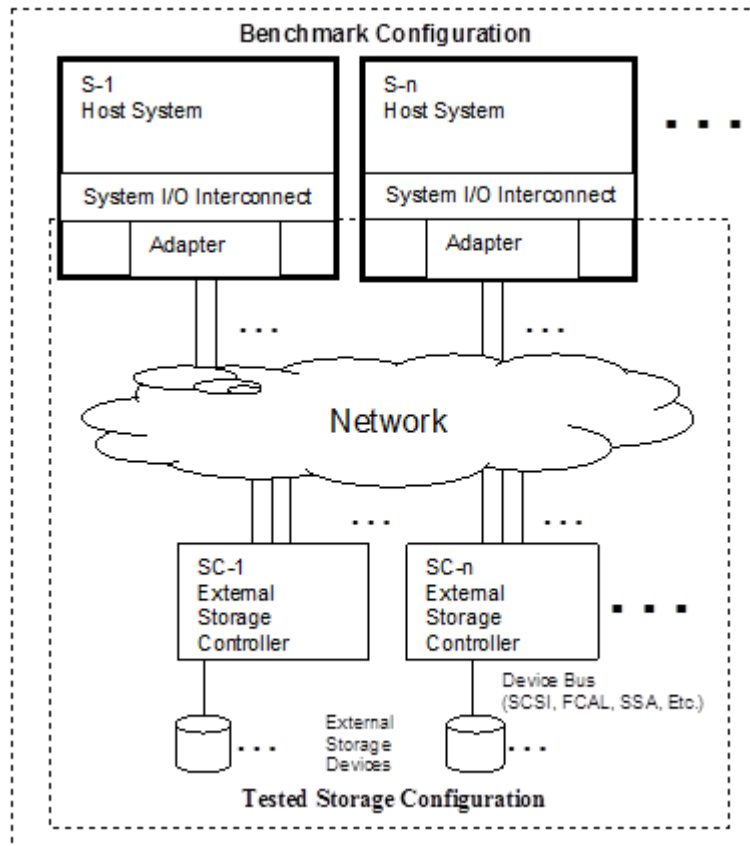

4.4.6 Network Storage – External Storage Controller and External Storage Devices

A network storage [TSC](#) utilizing external storage controllers and external [STORAGE DEVICE](#)s as illustrated in Figure 4-5.

The [TSC](#) typically includes the following components:

- One or more host bus adapters that connect the storage network into system I/O interconnect(s) on [HOST SYSTEM](#)(s).
- All network infrastructure including hubs, switches, bridges, routers, cables, connectors, as well as supporting cabinetry, cooling, power systems, and monitoring equipment/systems used to connect storage controllers the [HOST SYSTEM](#)(s).
- All software used to manage and maintain the network infrastructure.
- External storage controllers or domain controllers including:
 - Batteries used to maintain power to write cache in the storage controller in the event of unexpected power failure.

- Cabinetry used to house the storage controller.
- Monitoring systems and related cabling used to monitor the health of the storage controller.
- Equipment used to cool the storage controller.
- Power supplies and related cabling used to power the storage controller.
- Power distribution systems and related cabling used to route power to the storage controllers.
- All management software necessary to allow the storage controller(s) to present [ASUs](#) to the SPC-1 [WORKLOAD GENERATOR](#).
- [STORAGE DEVICES](#) to provide the various levels of storage described in Clause 2.
- Cabling between the storage controller and the [STORAGE DEVICES](#).
- Cabinetry used to house the [STORAGE DEVICES](#).
- Monitoring systems and related cabling used to monitor the health of the [STORAGE DEVICES](#).
- Equipment used to cool [STORAGE DEVICES](#).
- Power supplies and related cabling used to power the [STORAGE DEVICES](#).
- Power distribution systems and related cabling in [STORAGE DEVICE](#) cabinetry used to route power to the individual [STORAGE DEVICE](#) power supplies.
- All management software necessary to present and manage the [ASUs](#) to the SPC-1 [WORKLOAD GENERATOR](#).

4.5 Tested Storage Product

The [TESTED STORAGE PRODUCT \(TSP\)](#) is a distinct, customer orderable product, which is the focal point of an SPC [RESULT](#). Each SPC [RESULT](#) will be labeled with the formal name of the [TSP](#).

Clause 5 SPC Test Methodology

5.1 Defined Term Clarifications

5.1.1 In SPC-1, [STEADY STATE](#) is based on throughput and response time. As a general guideline, [STEADY STATE](#) is achieved when throughput and response time are stable and sustainable. Some behaviors, while not stable, still satisfy the [STEADY STATE](#) criteria, for example:

- Small and cyclical oscillation
- Brief excursion
- Significant but periodic events

Other behaviors, while following a stable dynamic, do not satisfy the [STEADY STATE](#) criteria, for example:

- Gradual and constant increase or decrease, amounting to a significant delta over the duration of a [MEASUREMENT INTERVAL](#)
- Sudden and permanent change in behavior

Figure 5-1 Test Phase

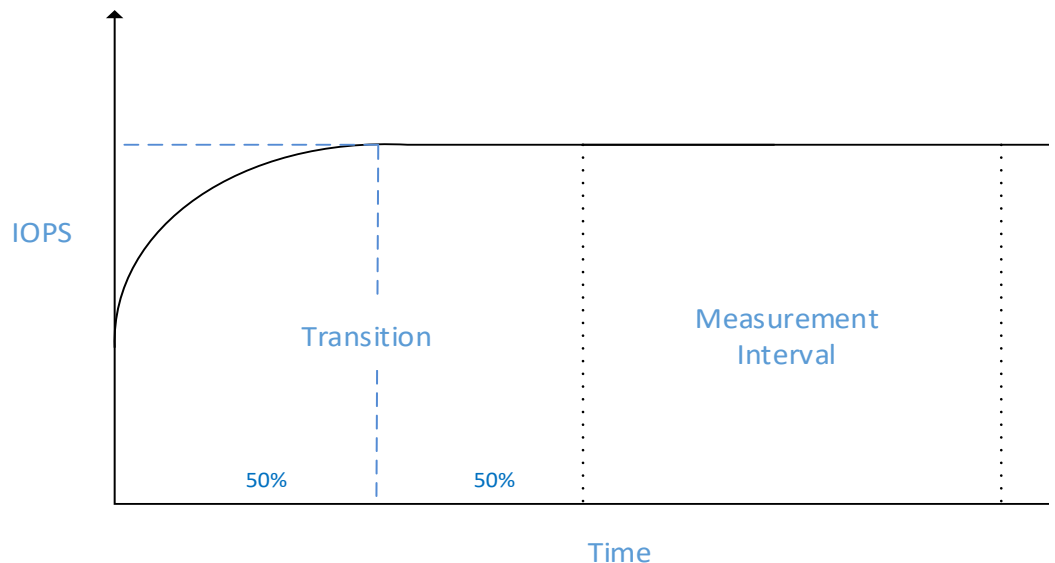

5.1.2 Test Phase

5.1.2.1 Each [TEST](#) is comprised of one or more [TEST PHASES](#). All [TEST PHASES](#) have a common structure (illustrated in Figure 5-1) comprised of three distinct sub-phases, which occur in the following sequence:

- [TRANSITION](#), during which the IO load presented by the SPC-1 [WORKLOAD GENERATOR](#) to the [TSC](#) is adjusted;
- [MEASUREMENT INTERVAL](#), during which the [TSC](#) shall be in [STEADY STATE](#);
- [RUNOUT](#), during which the IO load presented by the SPC-1 [WORKLOAD GENERATOR](#) to the

[TSC](#) remains constant long enough for any IO issued during the [MEASUREMENT INTERVAL](#) to complete.

Comment: *The IO load presented to the [TSC](#) during a [TEST PHASE](#) may be zero and a [TRANSITION](#) may occur either from or to an I/O load of zero. The load levels shown during the transition portion of the figure are for illustration only and reflect a typical case.*

5.1.2.2 Data about the [TSC](#)'s response to the stimulus of the SPC-1 [WORKLOAD GENERATOR](#) must be collected during all three sub-phases of each [TEST PHASE](#).

5.2 Requirements and Constraints

5.2.1 SPC Approved Workload Generator

5.2.1.1 All SPC-1 measurements shall be produced using a current, supported version of the SPC-1 toolkit.

5.2.1.2 The documentation included with the SPC-1 toolkit shall be considered an extension of this benchmark specification. It will describe the appropriate use of the tools within the SPC-1 toolkit.

5.2.1.3 The procedures, requirements, and constraints described in the SPC-1 toolkit documentation shall be adhered to in order to produce a compliant SPC-1 measurement.

5.2.1.4 All [TEST PHASE](#) results or data used to compute results shall be obtained from the SPC-1 [WORKLOAD GENERATOR](#)'s [RESULTS FILES](#).

5.2.2 SPC-1 Toolkit Precedence

In cases where the SPC-1 toolkit and this benchmark specification are in disagreement, the SPC-1 toolkit prevails. Therefore, any such disagreement may not serve as the basis for a compliance challenge. All aspects of the current version of the SPC-1 toolkit, as provided by the SPC, are deemed to be in compliance with this benchmark specification.

5.2.3 ASU Pre-Fill

5.2.3.1 Each of the [ASUs](#) defined for a [WORKLOAD](#) is required to be completely filled with specified content (see Clause 2.6) prior to execution of audited [TESTS](#).

5.2.3.2 If any of the [LOGICAL VOLUMES](#) that support the [ASUs](#) is space-optimized (see 2.7), then the following shall be disclosed:

- the [PHYSICAL FREE SPACE](#) of the [TSC](#), measured after the [LOGICAL VOLUMES](#) have been created but before the start of the [ASU](#) pre-fill, and
- the [PHYSICAL FREE SPACE](#) available in the [TSC](#), measured after the [ASU](#) pre-fill completes.

5.2.3.3 At the completion of the [ASU](#) pre-fill, the [TEST SPONSOR](#) must verify that the generated content matches the required content mix, using the SPC-1 [WORKLOAD GENERATOR](#) (see

6.3.4). If the verification fails, the [ASU](#) pre-fill must be re-run prior to the execution of the [TEST PHASES](#).

5.2.4 **Steady State**

The [TSC](#) shall be in [STEADY STATE](#) for the duration of each [MEASUREMENT INTERVAL](#).

5.2.5 **Benchmark Configuration Consistency**

5.2.5.1 The physical and logical configuration of the [BC](#) shall not be changed across [TESTS](#) or [TEST PHASES](#).

5.2.5.2 Configuration and tuning parameters of the [BC](#) shall not be changed across [TESTS](#) or [TEST PHASES](#).

5.2.6 **Failed I/O Requests**

All I/O REQUESTs initiated during any [TEST PHASE](#) in the SPC benchmark must complete during that [TEST PHASE](#). A [FAILED I/O REQUEST](#) shall result in an invalid [TEST PHASE](#).

This requirement applies to all sub-phases (i.e., [TRANSITION](#), [MEASUREMENT INTERVAL](#) and [RUNOUT](#)) within each [TEST PHASE](#).

5.2.7 **No Permitted Warm Up**

5.2.7.1 Other than booting/starting the [HOST SYSTEMS](#), bringing [ASUs](#) on-line for use by the SPC-1 [WORKLOAD GENERATOR](#), and starting the SPC-1 [WORKLOAD GENERATOR](#), no substantive work shall be performed on the [BC](#) prior to or in between SPC-1 TESTS or [TEST PHASES](#).

Comment: *It is the specific intent of this clause that the [TEST SPONSORS](#) not be allowed to optimize configuration or tuning parameters between [TESTS](#) or [TEST PHASES](#).*

5.2.8 **Adaptive Data Migration**

5.2.8.1 ADAPTIVE DATA MIGRATION causes [ASU](#) data to be migrated to alternate storage locations for subsequent access during [TESTS](#).

5.2.8.2 Alternate storage locations, when used as destinations for migrated data, must use one or more type of supported [STORAGE DEVICE](#).

5.2.8.3 Access to migrated data, during the [TESTS](#), must be transparent to the SPC-1 [WORKLOAD GENERATOR](#). When the SPC-1 [WORKLOAD GENERATOR](#) issues a reference to an [ASU](#) location, it is the responsibility of the [TSC](#) to transparently resolve the reference to the location of the migrated data.

5.2.8.4 If the [ASUs](#) exclude the storage which contains the alternate storage locations, that storage must provide data protection (see 2.8). The type of data protection provided by

that storage need not be identical to the data protection specified provided by the storage that comprises the [ASUs](#).

5.2.9 I/O Profile Preservation

5.2.9.1 Each execution of a [MEASUREMENT INTERVAL](#) during a [TEST PHASE](#) must produce [MEASURED I/O REQUESTS](#) that reflect the workload profiles that are defined in Clause 3.7.

5.2.9.2 For each I/O STREAM executed during a [TEST PHASE](#), the [MEASURED INTENSITY MULTIPLIER](#) must satisfy at least one of following conditions:

- The stream's [MEASURED INTENSITY MULTIPLIER](#) may differ from the intensity multiplier parameter defined for that I/O STREAM by no more than 5% of the value provided in Clause 3.7;
- The rate of [MEASURED I/O REQUESTS](#) for that I/O STREAM shall differ from the product of intensity multiplier parameter and [MEASURED I/O REQUESTS](#) by no more than 1 I/O per second.

5.2.9.3 For each [I/O STREAM](#) executed during a [TEST PHASE](#), the coefficient of variation for the [MEASURED INTENSITY MULTIPLIER](#) may be no more than 0.2, when calculated from the [MEASURED INTENSITY MULTIPLIER](#) reported at one minute intervals throughout the [MEASUREMENT INTERVAL](#) of the [TEST PHASE](#).

Coefficient of variation is defined to be:

$$V = \frac{\text{Stdev}(C)}{\text{Mean}(C)}$$

where:

V is the coefficient of variation

Stdev(C) is the standard deviation of the [MEASURED INTENSITY MULTIPLIER](#)

Mean(C) is the average of the [MEASURED INTENSITY MULTIPLIER](#)

5.2.9.4 A benchmark execution that produces a [MEASURED INTENSITY MULTIPLIER](#) that does not satisfy the requirements defined in 5.2.9 is not compliant with this specification.

5.2.10 IO Generation

The SPC-1 [WORKLOAD](#) is generated by one or more instances of the SPC-1 [WORKLOAD GENERATOR](#) running on one or more [HOST SYSTEMS](#) that are part of the [BENCHMARK CONFIGURATION](#) (see Clause 4). For more information on the execution and configuration of the SPC-1 [WORKLOAD GENERATOR](#), refer to the Users' Guide distributed with the toolkit for this benchmark specification.

The relationships between [I/O STREAMS](#) and [ASUs](#) are illustrated in Figure 5-2.

Figure 5-2 IO Requests from Multiple Hosts

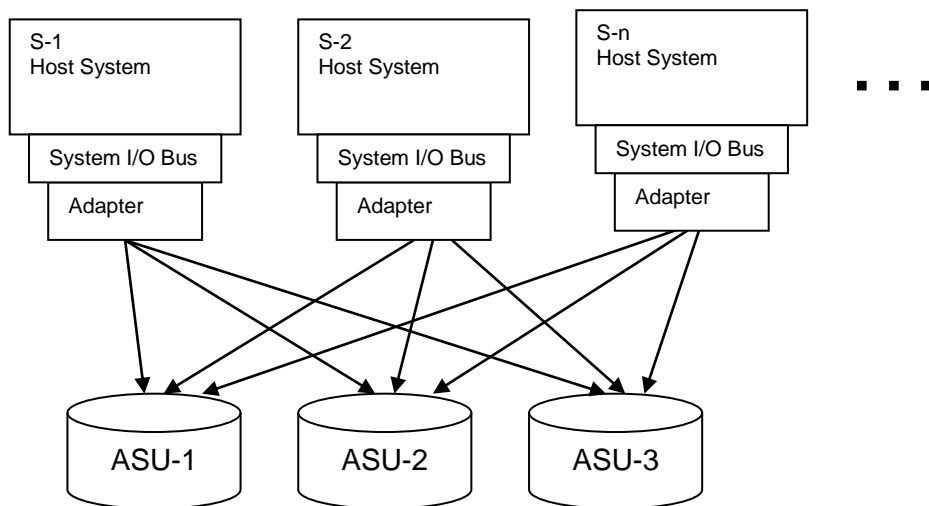

5.2.11 **Multi-Host Considerations**

5.2.11.1 The [TEST SPONSOR](#) may choose to configure multiple [HOST SYSTEMS](#) in a [BENCHMARK CONFIGURATION](#). In this case, the aggregate stimulus presented to each [ASU](#) from all [HOST SYSTEMS](#) shall preserve the workload parameters as defined in Clause 3.

5.2.11.2 Each instance of the [WORKLOAD GENERATOR](#), regardless of the [HOST SYSTEM](#) on which it executes, must access all of the [LOGICAL VOLUMES](#) that comprise the [ASUs](#), and must preserve the workload parameters as defined in Clause 3. See Figure 5-2 as an illustration of this requirement.

Comment: *It is the intent of this clause that multiple [WORKLOAD GENERATORS](#) spread across multiple [HOST SYSTEMS](#) effectively behave as a single [WORKLOAD GENERATOR](#) relative to the workload offered to the [TSC](#).*

- 5.2.11.3 The mapping from an [ASU](#)'s logical address to a [STORAGE DEVICE](#)'s physical address must be identical for all instances of the [WORKLOAD GENERATOR](#), regardless of the [HOST SYSTEM](#) on which it executes..

Figure 5-3 Measurement Boundary

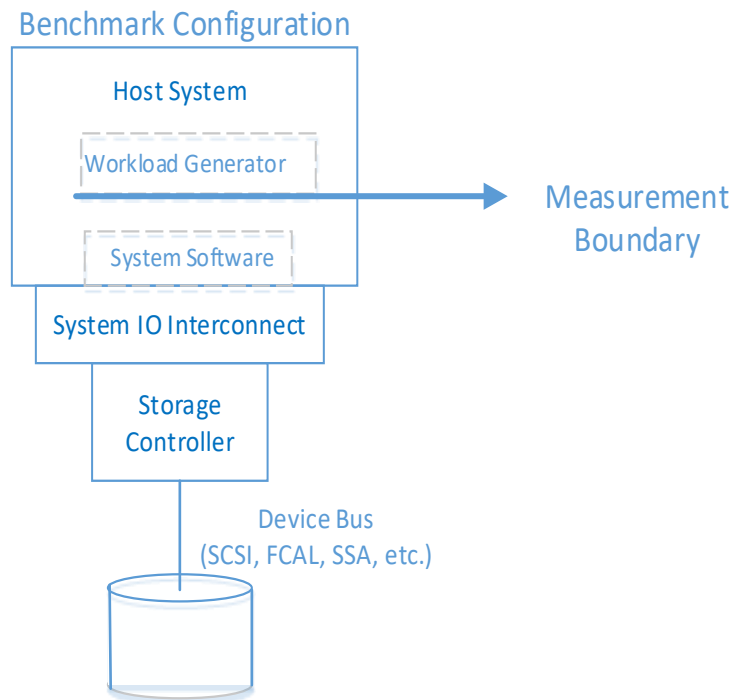

5.2.12 Measurement Boundary

The [MEASUREMENT BOUNDARY](#), (illustrated in Figure 5-3) occurs within the SPC-1 [WORKLOAD GENERATOR](#) where [I/O REQUEST START TIMES](#) and [COMPLETION TIMES](#) are recorded.

5.2.13 Un-Buffered ASU Access

No file system functionality, such as caching or pre-fetching, provided by the [HOST SYSTEM](#)(s) may be used when accessing an [ASU](#). As an example, the UNIX implementations of the SPC-1 [WORKLOAD GENERATOR](#) issues [I/O REQUESTS](#) via the raw, un-buffered I/O interface. Figure 5-4 illustrates that example.

All other operating system implementations of the SPC-1 [WORKLOAD GENERATOR](#) utilizes the operating system's mechanisms for performing I/O that is as close as possible to the raw, un-buffered I/O interface provided by UNIX.

5.2.14 No Operator Intervention

No user or operator intervention is allowed from the start of pre-fill to the completion of the persist_1 [TEST PHASE](#).

Figure 5-4 Measurement Boundary

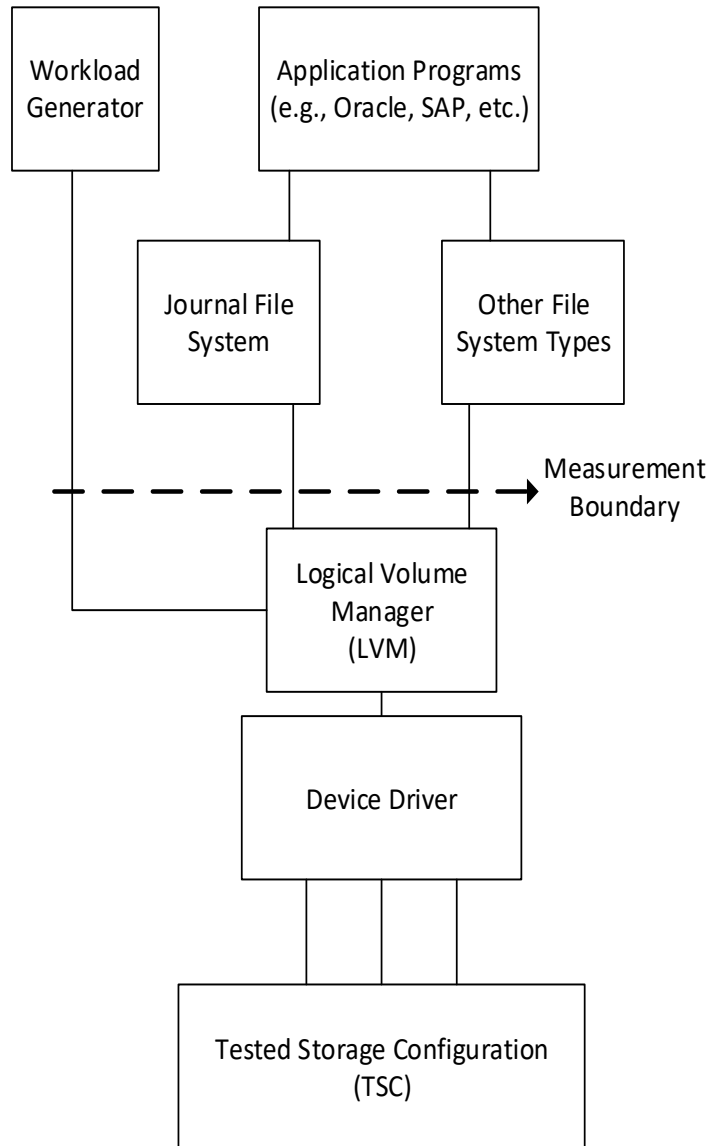

Clause 6 SPC-1 Measurement Requirements (Execution Rules)

6.1 Overview

An SPC-1 measurement includes the following [TESTS](#):

- The primary metrics [TEST](#) (Clause 6.3).
- The persistence [TEST](#) (Clause 7).

6.2 General Guidelines

6.2.1 SPC-1 conforms to the general SPC test methodology defined in Clause 5 except where explicitly over-ridden by requirements in Clause 6 or Clause 7.

6.2.2 The required [TESTS](#) must be executed as part of an uninterrupted benchmark execution sequence. That uninterrupted sequence will consist of:

- [ASU](#) Pre-Fill (See 5.2.3),
- PRIMARY METRICS [TEST](#) (See 6.3), and
- PERSISTENCE [TEST](#) (See Clause 7).

6.2.3 The required sequence must be uninterrupted from the start of the [ASU](#) pre-fill to the completion of PERSISTENCE [TEST](#), except as explicitly required by the execution rules. Uninterrupted means the [BENCHMARK CONFIGURATION](#) shall not be power cycled, restarted, disturbed, altered, or adjusted during the above measurement sequence. If the required sequence is interrupted other than for the [HOST SYSTEM/TSC](#) power cycle required during the PERSISTENCE [TEST](#), the measurement is invalid.

6.2.4 The [TEST SPONSOR](#) may employ a reasonable number of attempts to complete the required, benchmark execution sequence.

6.2.5 An exception may be made by the [AUDITOR](#) to the above requirement for an uninterrupted benchmark execution sequence. If such an exception is made, it must have no impact on the reported metrics, and be documented in the “Anomalies or Irregularities” section of the SPC-1 [FULL DISCLOSURE REPORT](#) as well as the “Audit Notes” portion of the Audit Certification Report.

6.3 Primary Metrics Test

6.3.1 Test Phase Summary

The PRIMARY METRICS [TEST](#) is comprised of the following [TEST PHASES](#), which shall be executed in an uninterrupted sequence as defined in Table 6-1.

Table 6-1 Primary Metrics Test Phases

Test Phase Group	Test Phase	Load Percentage	Required Durations		
			Transition (minimum)	Measurement Interval	RunOut
	SUSTAIN	100	3 minutes	8 hours (minimum)	1 minute
Response Time Ramp	RAMPD_100	100	3 minutes	10 minutes	1 minute
	RAMPD_95	95	3 minutes	10 minutes	1 minute
	RAMPD_90	90	3 minutes	10 minutes	1 minute
	RAMPD_80	80	3 minutes	10 minutes	1 minute
	RAMPD_50	50	3 minutes	10 minutes	1 minute
	RAMPD_10	10	3 minutes	10 minutes	1 minute
	RAMPU_50	50	3 minutes	10 minutes	1 minute
	RAMPU_80	80	3 minutes	10 minutes	1 minute
	RAMPU_90	90	3 minutes	10 minutes	1 minute
	RAMPU_95	95	3 minutes	10 minutes	1 minute
	RAMPU_100	100	3 minutes	10 minutes	1 minute
	RAMP_0	0	3 minutes	10 minutes	1 minute
Repeatability	REPEAT_1_10	10	3 minutes	10 minutes	1 minute
	REPEAT_1_100	100	3 minutes	10 minutes	1 minute
	REPEAT_2_10	10	3 minutes	10 minutes	1 minute
	REPEAT_2_100	100	3 minutes	10 minutes	1 minute

6.3.2 General Requirements

- 6.3.2.1 The [TRANSITION](#) durations listed in Table 6-1 are minimums, and may be increased at the [TEST SPONSOR](#)'s discretion.
- 6.3.2.2 The [TRANSITION](#) duration for each [TEST PHASE](#) in the PRIMARY METRICS [TEST](#) shall be identical with the exception of SUSTAIN, which is allowed to have a different [TRANSITION](#) duration.

Comment: *It is the intent of this clause to insure that the [BC](#) and [TSC](#) have demonstrated [STEADY STATE](#) in preparation for the reported SPC-1™ IOPS result.*

- 6.3.2.3 The [TEST PHASE](#)s will be executed with a single invocation of the SPC-1 [WORKLOAD GENERATOR](#), providing an uninterrupted sequence of [TEST PHASE](#)s, with each [TEST PHASE](#) immediately following its predecessor.
- 6.3.2.4 The [AVERAGE RESPONSE TIME](#) will be computed and reported for each [TEST PHASE](#) and cannot exceed 30 milliseconds. If the [AVERAGE RESPONSE TIME](#) exceeds that 30-millisecond constraint for any [TEST PHASE](#), the [MEASUREMENT](#) is invalid.
- 6.3.2.5 The [MEASURED INTENSITY MULTIPLIER](#) for each [I/O STREAM](#) in a [TEST PHASE](#) must satisfy the I/O mix requirements defined in 5.2.9.
- 6.3.2.6 The [TEST SPONSOR](#) shall do nothing to impact the [I/O REQUEST THROUGHPUT](#) between the end of one [TEST PHASE](#) and the beginning of the next.

Comment: *The intent of this clause is to ensure the load presented to the [TSC](#) during the transition between the two [TEST PHASE](#)s remains under the control of the SPC-1 [WORKLOAD GENERATOR](#), without any intervention from the [TEST SPONSOR](#).*

- 6.3.2.7 The [BC](#) or [TSC](#) may not be restarted between the [TEST PHASE](#)s.

6.3.3 Sustain Test Phase

- 6.3.3.1 The SUSTAIN [TEST PHASE](#) demonstrates the maximum sustainable [I/O REQUEST THROUGHPUT](#) within a continuous [MEASUREMENT INTERVAL](#) of at least eight (8) hours.

Comment: *It is the intent of this test that customers, consultants, or competitors be able to easily demonstrate that an SPC-1™ IOPS result can be consistently maintained over long periods of time as would be expected in system environments with demanding long term I/O request throughput requirements.*

- 6.3.3.2 The computed [I/O REQUEST THROUGHPUT](#) of this [TEST PHASE](#) must be within 5% the reported SPC-1 IOPS™ [RESULT](#). Thus, the SUSTAIN [TEST PHASE](#) can constrain the reported SPC-1™ IOPS [RESULT](#). The SUSTAIN [TEST PHASE](#) must be run at the same IO load level as the RAMPD_100 [TEST PHASE](#).

6.3.4 Content Verification

- 6.3.4.1 The execution of the PRIMARY METRICS [TEST](#) shall include a verification of content both before and after the performance tests. The [WORKLOAD GENERATOR](#) must gather samples for content verification immediately prior to the first performance test and immediately following the last performance test. The initial and final sample-gathering steps are referred to as VERIFY_1 and VERIFY_2, respectively. To establish run validity, both

samples must meet the statistical criteria applied by the currently available version of the toolkit.

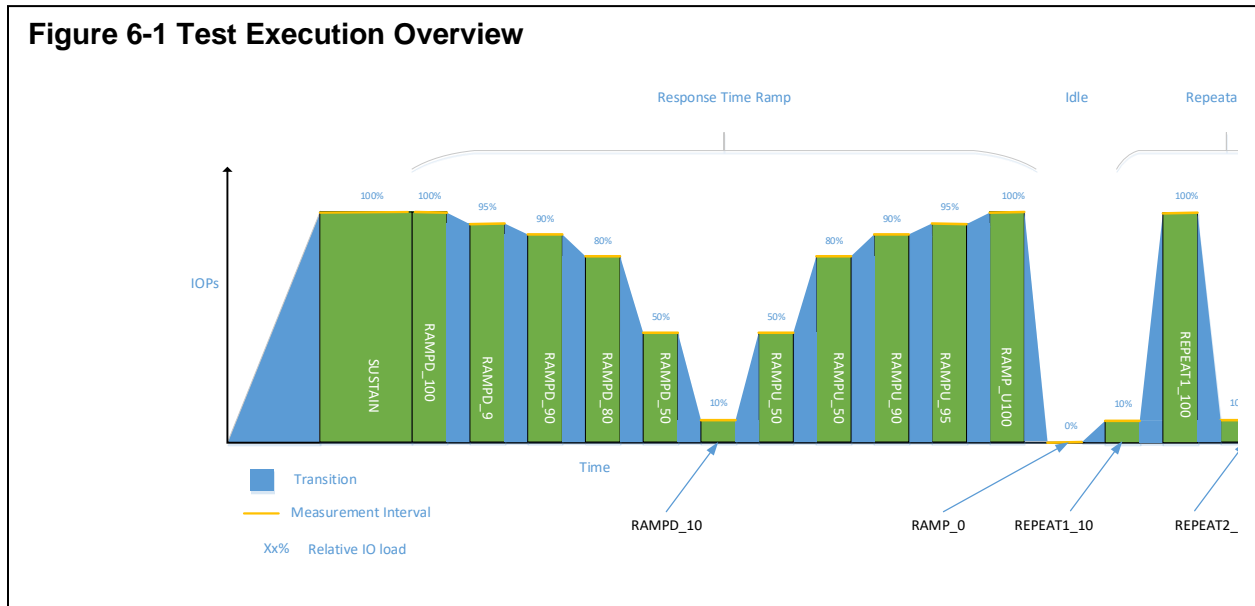

6.3.5 Response Time Ramp Test Phase Group

6.3.5.1 The [TEST PHASES](#) from RAMPD_100 through RAMPU_100 (inclusive) constitute the RESPONSE TIME RAMP component of the PRIMARY METRICS [TEST](#). By reporting [AVERAGE RESPONSE TIME](#) and [I/O REQUEST THROUGHPUT](#) at differing IO load levels, they demonstrate:

- The relationship between [AVERAGE RESPONSE TIME](#) and [I/O REQUEST THROUGHPUT](#) for the [TSC](#) (i.e., complete a response time/throughput curve).
- The (optimal) [AVERAGE RESPONSE TIME](#) of a lightly loaded [TSC](#).

6.3.5.2 The IO load level required for a given [TEST PHASE](#) shall be the integer value resulting from truncating the product of the IO load level used to report the SPC-1™ IOPS test result and the load percentage for the [TEST PHASE](#) from Table 6-1 Primary Metrics Test Phases.

6.3.5.3 The duration for each [MEASUREMENT INTERVAL](#) shall be equal to 10 minutes.

6.3.5.4 See Figure 6-1 Test Execution Overview for an illustration of the events and components of the Response Time Ramp [TEST PHASES](#) and their relationship to other [TEST PHASES](#) in this [TEST](#). This figure illustrates all [MEASUREMENT INTERVALS](#) associated with the PRIMARY METRICS [TEST](#). The figure is not to scale.

6.3.6 The final reported SPC-1 IOPS™ metric is deemed compliant, if the [I/O REQUEST THROUGHPUT](#) for the RAMPU_100 [TEST PHASE](#) is greater than the reported SPC-1 IOPS™ metric minus 5%. As such, the RAMPU_100 [TEST PHASES](#) will constrain the final reported SPC-1 IOPS™ metric.

Comment: *The intent is to apply a criterion similar to that used in the repeatability tests.*

6.3.7 Idle Test Phase

The idle [TEST PHASE](#) briefly quiesces the [TSC](#).

6.3.8 Repeatability Test Phase Group

- 6.3.8.1 The [TEST PHASE](#)s from REPEAT_1_10 through REPEAT_2_100 (inclusive) constitute the repeatability component of the PRIMARY METRICS [TEST](#). They demonstrate the repeatability and reproducibility of corresponding IO load points within the RESPONSE TIME RAMP test phase group.
- 6.3.8.2 The REPEAT_1_10 [TEST PHASE](#) must be identical to the REPEAT_2_10 [TEST PHASE](#) in terms of duration and IO load.
- 6.3.8.3 The REPEAT_1_100 [TEST PHASE](#) must be identical to the REPEAT_2_100 [TEST PHASE](#) in terms of duration and IO load.
- 6.3.8.4 If any of the four [TEST PHASE](#)s is not compliant, all four must be repeated.
- 6.3.8.5 The final reported SPC-1 IOPS™ metric is deemed reproducible and repeatable if the [I/O REQUEST THROUGHPUT](#) for the REPEAT_1_100 and REPEAT_2_100 [TEST PHASE](#)s are both greater than the reported SPC-1 IOPS™ metric minus 5%. As such, the REPEATABILITY [TEST PHASE](#)s will constrain the final reported SPC-1 IOPS™ metric.
- 6.3.8.6 The [AVERAGE RESPONSE TIME](#) from the RAMP_1_10 [TEST PHASE](#) is deemed reproducible and repeatable if the [AVERAGE RESPONSE TIME](#) for the REPEAT_1_10 and REPEAT_2_10 [TEST PHASE](#)s are each either less than the [AVERAGE RESPONSE TIME](#) from the RAMPD_10 [TEST PHASE](#) plus 5% or less than the [AVERAGE RESPONSE TIME](#) from the RAMPD_10 [TEST PHASE](#) plus one (1) millisecond (ms).
- 6.3.8.7 Each instance of the REPEATABILITY [TEST PHASE](#)s shall be run with a statistically distinct sequence of [I/O REQUESTS](#) to assure that prior cache contents do not affect the results of the current [TEST PHASE](#). The REPEATABILITY [TEST PHASE](#)s shall be run uninterrupted.
- 6.3.8.8 If any of the [LOGICAL VOLUMES](#) that support the [ASUs](#) are space-optimized (see 2.7), then the [PHYSICAL FREE SPACE](#) of the [TSC](#), measured after completion of the REPEAT_2_100 [TEST PHASE](#) shall be disclosed.

Clause 7 Data Persistence Requirements and Test

7.1 Introduction

[LOGICAL VOLUME](#)s and related [APPLICATION STORAGE UNIT](#)s must demonstrate the ability to preserve data across extended periods of power loss without corruption or loss. To provide this “persistence” capability, the [TESTED STORAGE CONFIGURATION](#) must use [LOGICAL VOLUME](#)s and related [ASU](#)s that:

- Are capable of maintaining all committed data across power cycles and outages.
- Ensure the transfer of data between [LOGICAL VOLUME](#)s and [HOST SYSTEM](#)s without corruption or loss.

7.2 Persistence Requirements

7.2.1 The [TSC](#) must be able to preserve all committed data in the event of any interruption of power. No test can conclusively prove that the [TSC](#) is capable of maintaining committed data through every unanticipated power loss. To satisfy the persistence requirements of SPC-1, the [TEST SPONSOR](#) must provide a written description of the mechanisms the [TSC](#) uses to persist committed data in the event of power loss (see 10.8.1.5), and the [TSC](#) must pass the persistence test as required by this clause.

7.2.2 In this specification, the phrase “committed data” refers to any data written by the application and positively acknowledged as written by the [TSC](#).

Comment: *Data contained in write operations that were in-flight at the time of a power loss are not committed data.*

7.3 Persistence Test Validation

Validation that the PERSISTENCE [TEST](#) completed successfully is provided by the [AUDITOR](#), attesting that the test has been satisfactorily completed on the [BC](#) per the test requirements below.

7.4 Test Phase Summary

7.4.1 Overview

During the PERSISTENCE TEST, the SPC-1 [WORKLOAD GENERATOR](#) writes a specific pattern at randomly selected locations throughout the [ASU CAPACITY](#). Following an orderly shutdown, the SPC-1 [WORKLOAD GENERATOR](#) verifies the bit patterns at those locations.

The PERSISTENCE [TEST](#) is comprised of the [TEST PHASE](#)s defined in Table 7-1 .

Table 7-1 Persistence Test Phases

Test Phase Group	Test Phase	Load Percentage	Required Durations		
			Transition (minimum)	Measurement Interval	RunOut
	Persist1	25	3 minutes	10 minutes	1 minute
	Persist2	25	0	0	0

The IO load level required for a given [TEST PHASE](#) shall be at least the integer value resulting from truncating the product of the I/O load level used to generate the reported SPC-1 IOPS™ rate and the load percentage for the [TEST PHASE](#) from Table 7-1 .

The required duration values for PERSIST2 are chosen to allow the [TEST PHASE](#) to run until it has verified all writes done during the PERSIST1 [TEST PHASE](#).

7.4.2 If either of the [TEST PHASE](#)s defined in Table 7-1 fails, the PERSISTENCE [TEST](#) must be re-run in its entirety. The [TEST SPONSOR](#) is allowed a reasonable number of attempts to complete the required [TEST PHASE](#) sequence.

7.4.3 **General Requirements**

7.4.3.1 The PERSISTENCE [TEST](#) conforms to the general SPC test methodology (see Clause 5) except where explicitly over-ridden in this clause.

7.4.3.2 The [TRANSITION](#) durations listed in Table 7-1 are minimums, and may be increased at the [TEST SPONSOR](#)'s discretion.

7.4.3.3 The [TRANSITION](#) duration listed in Table 7-1 for the PERSIST1 [TEST PHASE](#) is a minimum and may be increased at the [TEST SPONSOR](#)'s discretion. The [TRANSITION](#) duration listed in Table 7-1 for the PERSIST2 [TEST PHASE](#) shall not be changed.

7.4.3.4 The [TRANSITION](#) duration for each [TEST PHASE](#) in the PERSISTENCE [TEST](#) shall be identical.

7.4.3.5 The [TEST PHASE](#)s will be executed with two separate invocations of the SPC-1 [WORKLOAD GENERATOR](#), one for the PERSIST1 [TEST PHASE](#) and another for the PERSIST2 [TEST PHASE](#).

7.4.3.6 Immediately following the completion of the PERSIST1 [TEST PHASE](#), and prior executing the PERSIST2 [TEST PHASE](#), the [TEST SPONSOR](#) shall:

- Shutdown and power off the [TESTED STORAGE CONFIGURATION \(TSC\)](#). Any [TSC](#) caches employing battery backup must be flushed/emptied.
- If the [TSC](#) includes the [HOST SYSTEM](#)(s), shutdown and power off the [HOST SYSTEM](#)(s). Any [TSC](#) caches on the [HOST SYSTEM](#)(s) employing battery backup must be flushed/emptied. If the [TSC](#) does not include the [HOST SYSTEM](#)(s), there is no requirement for the [HOST SYSTEM](#) configuration to be shutdown and power cycled.
- Restart the [TSC](#) and, if the [HOST SYSTEM](#)(s) were shutdown, restart the [HOST SYSTEM](#)(s).

7.4.3.7 If the results of PERSIST2 [TEST PHASE](#) verify the bit patterns are correct and at the proper location, the PERSISTENCE [TEST](#) completes successfully. If the PERSIST2 [TEST PHASE](#) reports any verification error, the PERSISTENCE [TEST](#) fails.

Clause 8 Reported Data

8.1 SPC-1 Reported Data

SPC-1 REPORTED DATA consists of the following two groups of information:

- SPC-1 [PRIMARY METRICS](#) (defined in 8.2)
- SPC-1 [SECONDARY METRICS](#) (defined in 8.3) and
- SPC-1 [ASSOCIATED DATA](#) (defined in 8.4).

8.2 SPC-1 Primary Metrics

8.2.1 Overview

The SPC-1 [PRIMARY METRICS](#) consist of SPC-1 IOPS™ and SPC-1 PRICE-PERFORMANCE™, as defined in the following clauses.

8.2.2 SPC-1 IOPS™

8.2.2.1 SPC-1 IOPS™ is intended to rigorously document the maximum attainable [/O REQUEST THROUGHPUT](#) of the [TSC](#). It is defined as the [/O REQUEST THROUGHPUT](#) reported for the RAMPD_100 [TEST PHASE](#) as described in 6.3.

8.2.2.2 All public references to this metric must be labeled as “SPC-1 IOPS™” and expressed rounded down to the nearest integer.

8.2.3 SPC-1 Price-Performance™

8.2.3.1 SPC-1 PRICE-PERFORMANCE is defined as a ratio of the [TOTAL SYSTEM PRICE](#) (as defined in the *SPC Pricing Guide*) to the SPC-1 IOPS™. It is calculated as:

$$\text{SPC-1 Price-Performance}^{\text{TM}} = T/(I/1000)$$

Where:

T is [TOTAL SYSTEM PRICE](#)

I is SPC-1 IOPS™.

8.2.3.2 SPC-1 Price-Performance™ is the [PRICE-PERFORMANCE](#) metric for SPC-1.

8.2.3.3 SPC-1 Price-Performance™ and [TOTAL SYSTEM PRICE](#) are [PRICED DISCLOSURE ITEMS](#) for SPC-1. See *SPC Pricing Guide* for details on requirements for their presentation, resolution and reporting.

8.2.3.4 All public references to this metric must be labeled as “SPC-1 Price-Performance” and presented as \$xxx.xx/SPC-1 KIOPS™.

8.3 SPC-1 Secondary Metrics

8.3.1 Overview

The SPC-1 [SECONDARY METRICS](#) consist of SPC-1 IOPS™ RESPONSE TIME, SPC-1 Average Response Time, [ASU CAPACITY](#), SPC-1 ASU PRICE, and SPC-1 [SPACE EFFECTIVENESS RATIO](#), as defined in the following clauses, or in 10.9.

8.3.2 SPC-1 IOPS™ Response Time

8.3.2.1 SPC-1 IOPS™ RESPONSE TIME is the [AVERAGE RESPONSE TIME](#) reported for the RAMPD_100 [TEST PHASE](#) as defined in 6.3.

8.3.2.2 All public references to this metric must be labeled as “SPC-1 IOPS™ Response Time” and expressed in millisecond (ms) with at least 3 digits of precision.

8.3.3 SPC-1 Overall Response Time

8.3.3.1 The SPC-1 Overall Response Time is calculated from the [AVERAGE RESPONSE TIME](#) for the following [TEST PHASE](#)s: RAMPD_100, RAMPD_95, RAMPD_90 DOWN, RAMPD_80, RAMPD_50 and RAMPD_10.

8.3.3.2 SPC-1 Overall Response Time is calculated as follows, based on the Throughput and Response Time components listed in Table 8-1.

Table 8-1 Overall Response Time Components

Test Phase	Throughput	Response Time
RAMPD_100 (IOPS)	R100T	R100RT
RAMPD_95	R95T	R95RT
RAMPD_90	R90T	R90RT
RAMPD_80	R80T	R80RT
RAMPD_50	R50T	R50RT
RAMPD_10	R10T	R10RT

$$N = 0.5*(R100RT+R95RT)*(R100T-R95T) + 0.5*(R95RT+R90RT)*(R95T-R90T) + \\ 0.5*(R90RT+R80RT)*(R90T-R80T) + 0.5*(R80RT+R50RT)*(R80T-R50T) + \\ 0.5*(R50RT+R10RT)*(R50T-R10T)$$

$$\text{SPC-1 Overall Response Time} = N / (R100T - R10T)$$

8.3.3.3 All public references to this metric must be labeled as “SPC-1™ Overall Response Time” and expressed in millisecond (ms) with at least 3 digits of precision.

8.3.4 SPC-1 ASU Capacity

8.3.4.1 All public references to [ASU CAPACITY](#) must be labeled as “SPC-1 ASU Capacity” and expressed in GB, rounded down to the nearest integer.

8.3.5 SPC-1 ASU Price

8.3.5.1 SPC-1 [ASU PRICE](#) is [PRICED DISCLOSURE ITEM](#) for SPC-1. See Clause 5 of the *SPC Pricing Guide* for details on its proper resolution and formatting.

8.3.5.2 All public references to this metric must be labeled as “SPC-1 ASU Price”.

8.3.6 Total System Price

8.3.6.1 [TOTAL SYSTEM PRICE](#) is the total three-year pricing as defined in Clause 9.3.

8.3.6.2 [TOTAL SYSTEM PRICE](#) is a [PRICED DISCLOSURE ITEM](#) for SPC-1. See Clause 5 of the *SPC Pricing Guide* for details on its proper resolution and formatting.

8.3.6.3 All public references to this metric must be labeled as “SPC-1 Total System Price” and expressed as “\$xx,xxx.xx”.

8.4 SPC-1 Associated Data

8.4.1 Overview

The SPC-1 [ASSOCIATED DATA](#) consist of [PHYSICAL STORAGE CAPACITY](#), data protection level, [TESTED STORAGE PRODUCT](#) (TSP) category, and SPC-1 [SUBMISSION IDENTIFIER](#).

8.4.2 Data Protection Level

8.4.2.1 Data protection level is defined in Clause 2.8.

8.4.2.2 All Public references to the data protection level of a SPC-1 RESULT must state either “Protected 1” or “Protected 2”, as appropriate.

8.4.3 Physical Storage Capacity

8.4.3.1 [PHYSICAL STORAGE CAPACITY](#) is defined in Clause 2.2.7.

8.4.3.2 All public references to this metric must be labeled as “Physical Storage Capacity” and expressed in GB, rounded down to the nearest integer.

8.4.4 SPC-1 Submission Identifier

The SPC-1 [SUBMISSION IDENTIFIER](#) is a unique identifier, assigned by the SPC, for each new SPC-1 RESULT.

8.5 SPC-1 Results – Public Use Requirements

8.5.1 General Guidance

Section 11.2.1 of the *SPC Policies and Guidelines* defines the requirements for public use of SPC-1 [RESULTS](#). The following clauses present public use requirements in the context of SPC-1 [RESULTS](#). Section 11.2.1 of the *SPC Policies and Guidelines* should be reviewed in its entirety to ensure compliance with the complete set of requirements.

8.5.2 Referencing a Single SPC-1 Result

8.5.2.1 A public reference to an SPC-1 RESULT is required include one of the following:

- A complete URL (hyperlink) to the SPC-1 [RESULT'S](#) entry on the “SPC-1 Results” page of the SPC website.
- The complete set of SPC-1 [REPORTED DATA](#) as defined in Clause 8.1. This set of information shall use the same font style, font size, and text clarity for every item in the set. The set of information may appear as a text paragraph or table of information.
- In either case, the public reference must include the “current as of” date.

8.5.2.2 Any of the SPC-1 [REPORTED DATA](#) may be used in a public reference without stating the complete set of SPC-1 [REPORTED DATA](#) as long as the following requirements are met:

- The URL defined in Clause 8.5.2.1 is included in the public reference.
- The public reference includes the “current as of” date.

8.5.3 Referencing Two or More SPC-1 Results

If a public reference of two or more SPC-1 RESULTS does not include any comparison of SPC-1 [REPORTED DATA](#), the requirements in the *SPC Pricing Guide* and 8.5.2 are applicable.

8.5.4 Comparing Two or More SPC-1 Results

SPC-1 [REPORTED DATA](#) may be used in a public reference to compare two or more SPC-1 [RESULTS](#) under the following conditions:

- In addition to the SPC-1 [REPORTED DATA](#) used in the comparison, each referenced SPC-1 [result](#) must include either the complete set of SPC-1 [REPORTED DATA](#) or the URL defined in Clause 8.5.2.1.
- If the complete set of SPC-1 [REPORTED DATA](#) is included for one of the referenced SPC-1 [RESULTS](#), the complete set of SPC-1 [REPORTED DATA](#) must be included for all of the referenced results.
- The public reference must include the “current as of” date.
- If the public reference consists of printed or displayed materials, the required items for each SPC-1 [RESULT](#) must use the same font style, font size, and text clarity.
- The pricing currency and target country must both be identical when a comparison includes SPC-1 [PRICE-PERFORMANCE](#) and/or SPC-1 [TOTAL SYSTEM PRICE](#).

Clause 9 Pricing

9.1 Overview

This benchmark conforms to version 1.0 of the *SPC Pricing Guide*.

9.2 Priced Components

The priced components for SPC-1 include:

- The hardware and software components present in the [TSC](#).
- Any additional operational components required by the [TSC](#).
- Maintenance on all of the above components, according to version 1.0 of the *SPC Pricing Guide*.

9.3 Maintenance Duration

The maintenance period for SPC-1 shall be three (3) years.

9.4 Pricing Related Data

The [PRICED DISCLOSURE ITEMS](#) for SPC-1 include:

- [ASU PRICE](#)
- [TOTAL SYSTEM PRICE](#)

9.5 Pricing Disclosure

This benchmark requires all disclosures defined in version 1.0 of the *SPC Pricing Guide*, with the following exceptions:

- None for this benchmark revision.

Clause 10 Full Disclosure Report

10.1 Overview

The [FULL DISCLOSURE REPORT \(FDR\)](#) is a report detailing an SPC-1 benchmark [RESULT](#), along with the procedures, configuration, and equipment used to produce the [RESULT](#).

The [FDR](#) includes the following components:

- The [FULL DISCLOSURE REPORT \(“FDR”\)](#) (see 10.3.1)
- The [EXECUTIVE SUMMARY](#) (see 10.3.2)
- The [SUPPORTING FILES](#) (see 10.3.3)

Additional items or modifications to the items listed above may be included and/or required at the discretion of the [AUDITOR](#).

All components of the [FDR](#) must be electronically submitted by a [TEST SPONSOR](#) to the SPC Administrator after a successful completion of the required SPC-1 [AUDIT](#) and prior to any public use of the benchmark [RESULT](#).

An [FDR](#) is required for each SPC-1 [RESULT](#) and is intended to allow the replication of the [RESULT](#) given access to appropriate documentation and products.

10.2 Full Disclosure Report Requirements

10.2.1 Document Language

The [FDR](#) and the [EXECUTIVE SUMMARY](#) must be written in the English language.

10.2.2 Document Format

The [FDR](#) must be formatted as a stand-alone Adobe PDF document.

The [EXECUTIVE SUMMARY](#) must be formatted as a stand-alone Adobe PDF document, in addition to its inclusion in the [FDR](#).

10.2.3 Full Disclosure Report Availability

The [FDR](#) must be readily available to the public at a reasonable charge, similar to charges for similar documents by that [TEST SPONSOR](#).

10.3 Document Contents

10.3.1 Full Disclosure Report Document

The [FDR](#) must contain, in sequence:

- Front Matter, including in sequence:
 - Title Page (10.4.1)
 - Release and Trademarks Page (10.4.2)
 - Table of Contents (10.4.3)
 - Audit Certification (10.4.4)
 - Letter of Good Faith (10.4.5)
- Executive Summary (10.5)

- Pricing Details (10.6)
- Publication Details, including in sequence:
 - Test Sponsor and Contact Information (10.7.1)
 - Revision Information and Key Dates (10.7.2)
 - Exceptions and Waivers (10.7.3)
 - Derivative Result Information (10.7.4)
- Configuration Information, including in sequence:
 - Tested Storage Product Description (10.8.1)
 - Host System and Tested Storage Configuration Components (10.8.2)
 - Configuration Diagrams (10.8.3)
 - Benchmark Configuration Creation Process (10.8.4)
- Space Optimization Information
 - Space Optimization Techniques (10.8.5.1)
 - Physical Space Utilization (10.8.5.2)
 - Space Optimization Reporting (10.8.5.3)
- Benchmark Execution Results, including in sequence:
 - Benchmark Execution Overview (10.9.1)
 - ASU Pre-Fill (10.9.2)
 - SUSTAIN Test Phase (10.9.3)
 - RAMPD_100 Test Phase (10.9.4)
 - Response Time Ramp Test (10.9.5)
 - Repeatability Test Phase Group (10.9.6)
 - Data Persistence Test (10.9.7)
- Benchmark Extension Results (10.10)
- Appendices
 - The list of [SUPPORTING FILES](#)
 - The third-party quotations, if any.

10.3.2 **Executive Summary**

The [EXECUTIVE SUMMARY](#) must contain and be limited to the content defined in 10.5.

10.3.3 **Supporting Files**

For this benchmark, the [SUPPORTING FILES](#) shall contain scripts, configuration files or other tools used in or produced during the measurement that was the basis of a given result. The precise contents of the [SUPPORTING FILES](#) will be determined by the [AUDITOR](#) for a given [RESULT](#), but they will typically include:

- all configuration scripts and settings used to tune or adjust the [HOST SYSTEM\(S\)](#),
- all configuration scripts and settings used to tune or adjust the storage hierarchy,
- system output related to [BC](#) and [TSC](#) inventories,
- all configuration scripts and settings used to drive the [WORKLOAD GENERATOR](#),
- all summaries, spreadsheets and graphs produced during the post-processing of a measurement to produce the [RESULT](#).

10.4 **Front Matter**

10.4.1 **Title Page**

The Title Page of the [FDR](#) must contain the following information:

- Title: “SPC-1 Benchmark Full Disclosure Report”
- The applicable SPC-1 Benchmark Specification version
- The [TEST SPONSOR](#)’s name and, optionally, a company logo
- The formal [TESTED STORAGE PRODUCT](#) name.
- The SPC-1 [SUBMISSION IDENTIFIER](#) assigned to the SPC-1 [RESULT](#) disclosed in the [FDR](#).
- The “Submitted for Review” notation and date, which designates the submission as a new SPC-1 [RESULT](#) and indicates the start of the 60-day Peer Review, as defined in the *SPC Policies and Guidelines*.

10.4.2 **Release and Trademarks Page**

This page of the [FDR](#) must contain:

- A release from the [TEST SPONSOR](#) allowing conditional public disclosure and reproduction of the [FDR](#).
- A list of the trademarks claimed by the SPC and by the [TEST SPONSOR](#).
- A reference to this Benchmark Specification document and to the glossary of terms used in the [FDR](#).

10.4.3 **Table of Contents**

The Table of Contents must identify the location of each 1st and 2nd level heading in the [FDR](#) .

10.4.4 **Audit Certification**

This section of the [FDR](#) must contain a copy of the certification letter issued by the [AUDITOR](#) to the [TEST SPONSOR](#) for this execution of the SPC-1 [BENCHMARK](#).

If the [FDR](#) is a revision to an existing [FDR](#) and contains changes to the original [PRICED STORAGE CONFIGURATION](#), the revised [FDR](#) must contain an amended certification letter that includes the [AUDITOR](#)’s review and approval of those changes.

10.4.5 **Letter of Good Faith**

This section of the [FDR](#) must contain a copy of the Letter of Good Faith issued by the [TEST SPONSOR](#) to the [AUDITOR](#) for this execution of the SPC-1 [BENCHMARK](#). The Letter of Good Faith is required to be identical in format and content to the template in Appendix A with the appropriate changes specific to the benchmark submission ([TEST SPONSOR](#) name, [TSC](#) name, date, etc.). Any other changes in content and format must be approved by the [AUDITOR](#).

10.5 **Executive Summary**

10.5.1 **Overview**

This section of the [FDR](#) must faithfully mimic the format and content of the template [EXECUTIVE SUMMARY](#) included in Appendix D, with the appropriate changes specific to the benchmark submission.

Detailed Content

While GoldStar results impose some additional formatting requirements on the [EXECUTIVE SUMMARY](#) (see 10.5.3), all [EXECUTIVE SUMMARY](#) (s) shall contain:

- A header section including:
 - The SPC's logo
 - Title: "SPC Benchmark 1™ Executive Summary"
 - The [TEST SPONSOR](#)'s logo or name
- The formal [TESTED STORAGE PRODUCT](#) name
- A metrics section including:
 - SPC-1 IOPS (8.2.2)
 - SPC-1 Price-Performance (8.2.3)
 - SPC-1 IOPS Response Time (8.3.2)
 - SPC-1 total system price (8.3.6)
 - SPC-1 overall response time (8.3.3)
 - SPC-1 overall discount (as defined in the *SPC Pricing Guide, version 1.0*)
- An availability section including:
 - The currency used in the pricing and the TARGET COUNTRY
 - The [AVAILABILITY DATE](#)
- A summary of the benchmark extensions included in the result
- A storage capacities section, including:
 - SPC-1 data protection level (see 2.8),
 - SPC-1 [PHYSICAL STORAGE CAPACITY](#) (2.2)
 - SPC-1 [ASU CAPACITY](#)
 - SPC-1 [ASU PRICE](#)
- The response time and throughput graph, as produced by the data reduction tool. The graph must a plot of the IOPS and the AVERAGE RESPONSE TIME for the following [TEST PHASES](#): RAMPD_100, RAMPD_95, RAMPD_90 DOWN, RAMPD_80, RAMPD_50 and RAMPD_10. The graph must also show a line representing the SPC-1 Average Response Time.
- The throughput graph from the SUSTAIN [TEST PHASE](#), as produced by a supported version of the SPC-1 data reduction tool.
- The throughput graph from the RAMPD_100 [TEST PHASE](#), as produced by a supported version of the SPC-1 data reduction tool.
- A [PRICE STORAGE CONFIGURATION](#) section, including:
 - A summary of the major components of the [PSC](#)
 - The total RU consumed by the configuration
- A revision section, including:
 - The applicable SPC-1 Benchmark Specification version
 - The SPC-1 [SUBMISSION IDENTIFIER](#) assigned to the RESULT.
 - The applicable SPC-1 [WORKLOAD GENERATOR](#) version
 - The "Submitted for Review" date.
 - The URL for the [RESULT](#) on the SPC web site

10.5.3 GoldStar Requirements

10.5.3.1 GoldStar results shall replace the SPC logo with the GoldStar logo variant.

10.5.3.2 Goldstar results shall include a “Gold Star Result” call out above the extension summary

10.6 Pricing Details

This section of the [FDR](#) must contain the following information, in sequence:

- The Pricing Spreadsheet (see SPC Pricing Guide, version 1.0)
- Discount and Warrantee Details (see SPC Pricing, version 1.0)
- a description of any differences between the [TSC](#) and the [PRICED STORAGE CONFIGURATION](#).

10.7 Publication Details

10.7.1 Test Sponsor and Contact Information

This section of the [FDR](#) must contain a table of contact information for the [TEST SPONSOR](#) and the [AUDITOR](#). The appearance, content and format of the table containing this information are illustrated by example in Table 10-1.

Table 10-1 Contact Information

Role	Name	Details
Test Sponsor Primary Contact (1)	Company's Name Individual's Name	Company's Web Address, Individual's Email Address
SPC Auditor (2)	Company's Name Individual's Name	Company's Web Address, Individual's Email Address

Footnotes to Table 10-1:

1. *The primary entity and first contact responsible for the submitted FDR. Entity will be the first point of contact in administrating results through the SPC Review Process.*
2. *Contact information for the AUDITOR who certified the new SPC-1 RESULT.*

10.7.2 Revision Information and Key Dates

This section of the [FDR](#) must contain a table of key dates and revision numbers associated with the published result. The content, appearance, and format of this table are illustrated by example in Table 10-2.

Table 10-2 Revision Information and Key Dates

Date	FDR Revision	Details
{submission date}	{FDR Edition}	{brief description}

10.7.3 Exceptions and Waivers

This section of the [FDR](#) must contain a description of any exceptions or waivers associated with the result.

10.7.4 Derivative Result Information

If the new SPC-1 [RESULT](#) is based on an existing SPC-1 [RESULT](#) (i.e., a SOURCE SPC-1 [RESULT](#)), the [FDR](#) must contain a table with the following information regarding the SOURCE SPC-1 [RESULT](#):

- The [SUBMISSION IDENTIFIER](#)
- The submission date
- The [TEST SPONSOR'S](#) primary contact information
- The [AUDITOR'S](#) contact information

The content and format of the table are illustrated by example in Table 10-3.

Table 10-3 Source SPC-1 Result Information

Source SPC-1 Result Information	
Source Test Sponsor Primary Contact (1)	Company, Company Web Address, Individual Name – Email Address Phone
Source SPC-1 Submission Identifier (2)	Annrrrr
Submission Date of Source SPC-1 Result (3)	mmmm dd, yyyy
Status of The Source SPC-1 Result (4)	{Submitted for Review/Accepted}
Auditor for The Source SPC-1 Result (5)	Company, Company Web Address, Individual Name – Email Address Phone

Footnotes to Table 10-3:

1. The [TEST SPONSOR](#) contact responsible for the SOURCE SPC-1 [RESULT](#).
2. The SPC-1 [SUBMISSION IDENTIFIER](#) of the SOURCE SPC-1 [RESULT](#).
3. The date the SOURCE SPC-1 [RESULT](#) was submitted to the SPC.
4. The current Peer Review status of the SOURCE SPC-1 [RESULT](#).
5. The [AUDITOR](#) for the SOURCE SPC-1 [RESULT](#).

The [FDR](#) must contain the [BC/TSC](#) diagram (Clause 10.8.3.1), the storage network diagram (Clause 10.8.3.2), and the [HOST SYSTEM/TSC](#) component table (Clause 10.7.4), from the SOURCE SPC-1 [RESULT](#). This information must appear in an appendix.

10.8 Configuration Information

10.8.1 Tested Storage Product Description

- 10.8.1.1 This section of the [FDR](#) must contain a brief description of the [TESTED STORAGE PRODUCT](#) (“[TSP](#)”). The description should include information that is consistent with the [TSP](#) categorization defined in Clause 4.5.
- 10.8.1.2 Features used in the benchmark by the [tsp](#) may be included in the description. For example, if the [tsp](#) is a software product that provides virtualization functionality used in the benchmark but does not include storage devices, the description should contain that information.
- 10.8.1.3 Features available in the [TSP](#), but not used in the benchmark cannot be included in the description.
- 10.8.1.4 The description may include a website link to official product information available from the test sponsor.
- 10.8.1.5 Features of the [TSC](#) and its architecture that ensure that it can survive the instantaneous loss of power to the entire [TSC](#) at any time without the loss of any committed data must be described (see 7.2).

10.8.2 Host System and Tested Storage Configuration Components

Table 10-4 Host System

Host System
Host System name/model (1)
CPU information (2)
Main Memory configuration (3)
Operating system name and version (4)
TSC Software (5)

Footnotes to Table 10-4:

1. The product name and model of each [HOST SYSTEM](#) used in the benchmark.
2. The number, product/model name, and description of the CPUs in each [HOST SYSTEM](#). The description will include clock speed.
3. The amount of main memory in each [HOST SYSTEM](#).
4. The operating system, version, and any specific patches/updates installed on each [HOST SYSTEM](#).
5. Any software, other than the operating system, installed on the [HOST SYSTEM](#) that provided [TSC](#) functionality such as a volume manager.

The [FDR](#) must contain a table that lists the major components of each [HOST SYSTEM](#) and of the [TESTED STORAGE CONFIGURATION](#). The content, appearance, and format of this

table are illustrated by example in Table 10-4 and Table 10-5.

Table 10-5 Tested Storage Configuration

Tested Storage Configuration
Host Bus Adapter (HBA) information (1)
TSC product name (2)
Storage/Domain Controller information (3)
Front-end interconnection information (4)
Back-end interconnection information (5)
STORAGE DEVICE information (6)
All other major TSC components (7) (e.g. switches, enclosures, etc.)

Footnotes to Table 10-5:

1. *The number, product / model name and description of all Host Bus Adapters installed on each [HOST SYSTEM](#).*
2. *The [TESTED STORAGE CONFIGURATION](#)'s product name and model.*
3. *The model / name and description of each storage / domain controller in the [TSC](#). The description will include:*
 - *The amount of memory and cache.*
 - *The type and total number of front-end physical connections.*
 - *The type and total number of back-end physical connections.*
 - *The type of physical connection between the [HOST SYSTEM](#) and storage / domain controller*
 - *The number of [STORAGE DEVICES](#) accessible by the storage / domain controller.*
4. *The number of physical front-end connections used in the benchmark.*
5. *The number of physical back-end physical connections used in the benchmark and the number of [STORAGE DEVICES](#) accessible by each connection.*
6. *The number of [STORAGE DEVICES](#) in the [TSC](#) and a description of each type of [STORAGE DEVICE](#). The description will include:*
 - *The type of device (disk drive, solid state device, etc.).*
 - *The formatted capacity of each [STORAGE DEVICE](#) type.*
 - *The rotation speed, if appropriate, of each [STORAGE DEVICE](#) type.*
 - *The amount of cache in each [STORAGE DEVICE](#) type.*
7. *All other major [TSC](#) components such as switches, enclosures, etc.*

10.8.2.1 Component Changes in Revised Full Disclosure Report

In cases where the [FULL DISCLOSURE REPORT](#) is revised to change one or more components of the [PRICED STORAGE CONFIGURATION](#), the revised [FDR](#) must contain a list of all [PRICED STORAGE CONFIGURATION](#) component changes that are included in this revision (see Clause 9.4). The list must contain the line item information of each original component, the line item information of the revised component, and a brief description of the change.

In the initial submission of the [FDR](#) the list of revised components will read “n/a” and the description will read “Initial Submission”.

10.8.3 Configuration Diagrams

10.8.3.1 BC and TSC Diagrams

The [FDR](#) must contain a one page diagram of the [BC](#) and [TSC](#) illustrating the following information:

- All [HOST SYSTEMS](#) and Management Appliances in the [BC](#). Each [HOST SYSTEM](#) shall designate (in sequence):
 - The model or name of the product.
 - The number of CPUs or processors.
 - The amount of main memory in the system.
 - The name and revision(s) of the operating system.
 - The type of System I/O Interconnect.
 - The type of physical connections between Adapters (connected to the System I/O Interconnect) and any Storage Controllers or [STORAGE DEVICES](#).
- All Storage Controllers or Domain Controllers in the [TSC](#). Each Controller shall designate (in sequence):
 - The model or name.
 - The amount of memory and cache.
 - The number of Front-end physical interconnects (unless there are none).
 - The type of Front-end interconnects (unless there are none).
 - The number of Back-end physical interconnects.
 - The type of Back-end physical interconnects.
 - The type of physical connections between Adapters (connected to the System I/O Interconnect) and any Storage Controllers or [STORAGE DEVICES](#).
- The number of [STORAGE DEVICE](#) as well as their capacities.
- An illustration and description of the networks used to implement the [BC](#). If a single diagram is not sufficient to illustrate both the [BENCHMARK CONFIGURATION](#) and network configuration in sufficient detail, the [BENCHMARK CONFIGURATION](#) diagram will include a high-level network illustration as shown in Figure 10-2

The content, appearance, and format of this diagram are illustrated by example in Figure 10-1.

Figure 10-1 BC/TSC Configuration Diagram

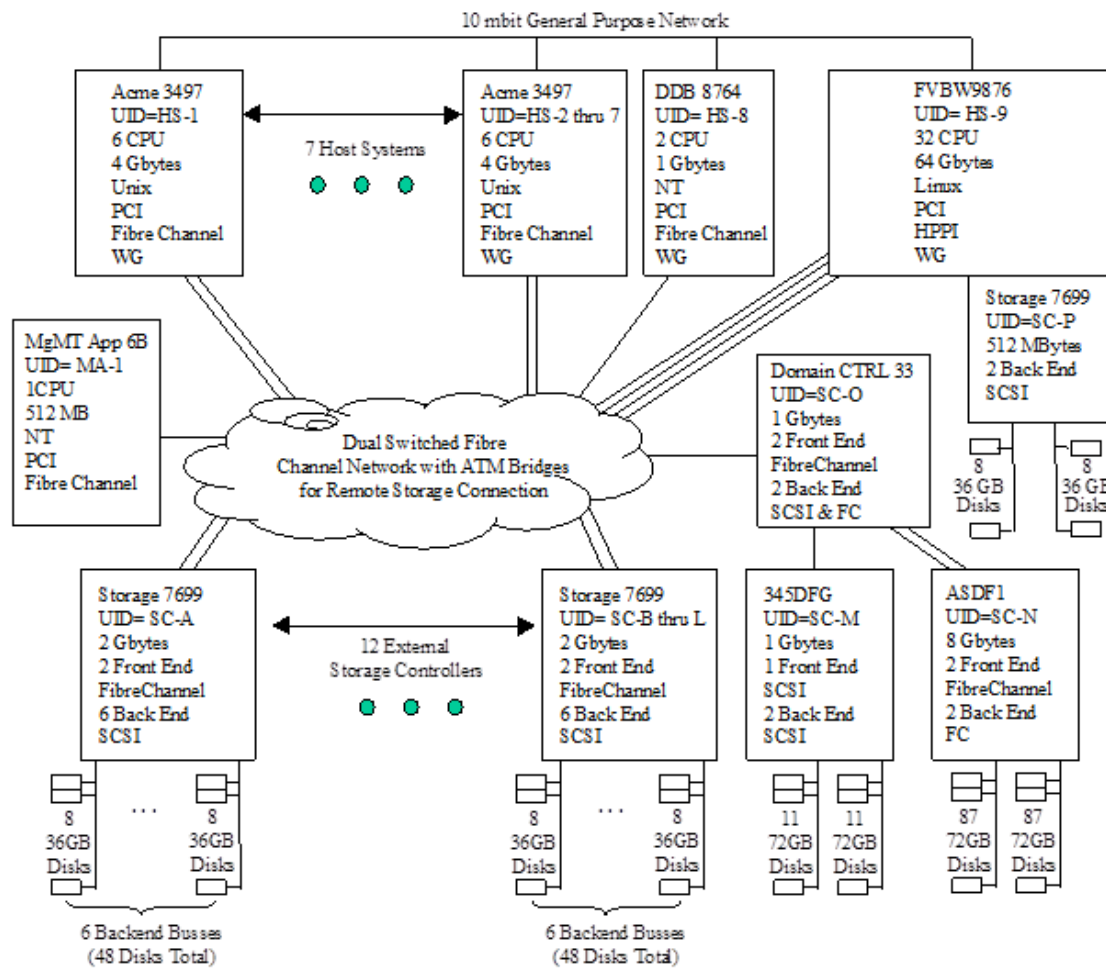

Comment: Detailed diagrams for system configurations and architectures can widely vary, and general guidelines may not be suitable for all implementations. The intent is to describe the system components and connections in sufficient detail to allow independent reconstruction of the [BC](#) environment.

10.8.3.2 Storage Network Configuration

If a storage network was included as a part of the [TESTED STORAGE CONFIGURATION](#) and the [BENCHMARK CONFIGURATION](#) diagram described in Clause 10.8.3.1 sufficiently illustrates the network configuration, the [FDR](#) must contain a brief description of the illustrated network.

If the network configuration cannot be adequately represented in the diagram described in Clause 10.8.3.1, the [FDR](#) must contain a one-page topology diagram, illustrating the following information:

- Storage Controllers and Domain Controllers (see Clause 10.8.3.1)
- [HOST SYSTEM](#)(s) (see Clause 10.8.3.1)
- Routers and Bridges
- Hubs and Switches
- HBAs to [HOST SYSTEM](#)s and Front End Port to Storage Controllers.

Additionally, the diagram must:

- Illustrate the physical connection between components.
- Describe the type of each physical connection.
- Describe the network protocol used over each physical connection.
- List the maximum theoretical transfer rate of each class of interconnect used in the configuration.
- Correlate with the [BC](#) Configuration Diagram in Clause 10.8.3.1.

The content, appearance, and format of this diagram are illustrated by example in Figure 10.2.

Figure 10-2 Storage Network Configuration Diagram

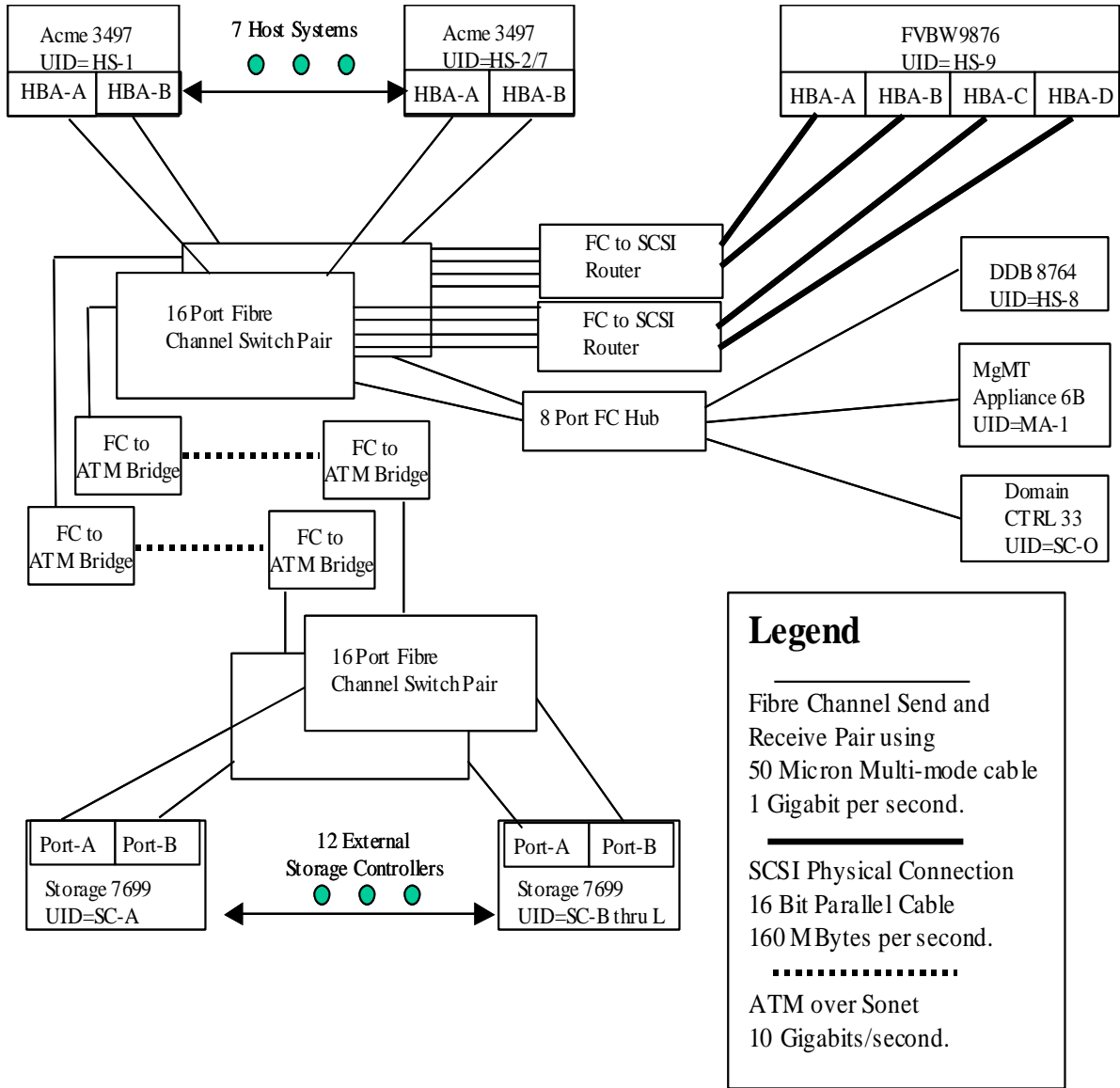

10.8.4 **Benchmark Configuration Creation Process**

10.8.4.1 Overview

The [FDR](#) must contain all the information necessary to recreate the complete [BENCHMARK CONFIGURATION](#).

10.8.4.2 Customer Tuning Parameters and Options

All [BENCHMARK CONFIGURATION](#) components with customer tunable parameters and options that have been altered from their default values must be listed in the [FDR](#). This

information must also be included in the [SUPPORTING FILES](#). The entry for each of those components must include both the name of the component and the altered value of the parameter or option. If the parameter name is not self-explanatory to a knowledgeable practitioner, a brief description of the parameter's use must also be included in the [FDR](#).

Examples of customer tunable parameters and options include:

- Options for each component used in a network used to connect Storage to [HOST SYSTEMS](#).
- HBA Options.
- Array Controller options.
- Operating system, run time environment, and application configuration parameters.
- Compilation and linkage options and run-time optimizations used to create/install any applications or the OS used on the [BC](#).

10.8.4.3 Tested Storage Configuration Creation

The [FDR](#) must contain sufficient information to recreate the logical representation of the [TSC](#). This information must also be included in the [SUPPORTING FILES](#). In addition to customer tunable parameters and options, that information must include at a minimum, the following:

- A diagram and/or description of the following:
 - All physical components that comprise the [TSC](#). Those components are also illustrated in the [BC](#) configuration diagram in Clause 10.8.3.1 and/or the storage network configuration diagram in Clause 10.8.3.2.
 - The logical representation of the [TSC](#) presented to the SPC-1 [WORKLOAD GENERATOR](#).
- Listings of scripts used to create the logical representation of the [TSC](#).
- If scripts were not used, a description of the process used with sufficient detail to recreate the logical representation of the [TSC](#).

10.8.4.4 Test Storage Configuration Inventory

An inventory of the components in the [TSC](#) as seen by the [BENCHMARK CONFIGURATION](#) must be included in the [FDR](#) or the [SUPPORTING FILES](#).

10.8.4.5 Workload Generator Storage Configuration

The [FDR](#) must contain all SPC-1 [WORKLOAD GENERATOR](#) storage configuration commands and parameters. (See *SPC Workload Generator Users' Guide* for details). This information must also be included in the [SUPPORTING FILES](#).

10.8.4.6 Logical Volume Addressable Capacity and ASU Mapping

The [FDR](#) must contain a table illustrating the capacity of each [ASU](#) and the mapping of [ASU](#) to [LOGICAL VOLUME](#) presented as follows:

- Capacities must be stated in gigabytes (GB) as a truncated integer or a truncated value with three significant digits, using the method that produces the more precise value.
- [LOGICAL VOLUMES](#) must be sequenced in the table from top to bottom per their position in the contiguous address space of each [ASU](#).

- The addressable capacity of each [LOGICAL VOLUME](#) must be stated.
- If space optimization was employed within an [ASU](#) (see 2.7), it shall be disclosed, and the [TEST SPONSOR](#) shall include a description of the techniques employed (see 10.8.5.1).

The content, appearance, and format of this table are illustrated by example in Table 10-6.

Table 10-6 Logical Volume Addressable Capacity and ASU Mapping

	LV per ASU	LV Capacity	Used per LV	Total per ASU	% ASU Capacity	Optimized
ASU-1	N	N,NNN.N	N,NNN.N	N,NNN.N	NN.N%	Y/N
ASU-2	N	N,NNN.N	N,NNN.N	N,NNN.N	NN.N%	Y/N
ASU-3	N	N,NNN.N	N,NNN.N	N,NNN.N	NN.N%	Y/N
SPC-1 ASU Capacity				NN.NNN.N		

10.8.4.7 Physical Storage Capacity and Utilization

The [FDR](#) must contain a table providing a list of the [STORAGE DEVICES](#) and their physical capacity, the [PHYSICAL STORAGE CAPACITY](#) of the [TESTED STORAGE CONFIGURATION](#) and the [PHYSICAL CAPACITY UTILIZATION](#).

The content, appearance, and format of this table are illustrated by example in Table 10-5

Table 10-7 Physical Capacity and Storage Device Summary

Devices	Count	Physical Capacity	Total Capacity
Storage device description	NN	NNN.N	NN.NNN.N
Storage device description	NN	NNN.N	NN.NNN.N
Storage device description	NN	NNN.N	NN.NNN.N
Total Physical Capacity			NNN.NNN.N
Physical Capacity Utilization			NN.NN%

10.8.4.8 Data Protection

The [FDR](#) must contain a description of the type of data protection (see Clause 2.8) used on each [LOGICAL VOLUME](#).

10.8.5 **Space Optimization Information**

10.8.5.1 Space Optimization Techniques

If any of the [ASUs](#) employ space optimization, the test sponsor shall include a description of the technique utilized. The description of the space optimization techniques is intended to provide a knowledgeable reader with a general understanding the precise

Table 10-8 Space Utilization Results

Physical Free Space Measurement	Free Space
After Logical Volume Creation	xxx,xxx.xx GB
After ASU Pre-Fill	xxx,xxx.xx GB
After Repeatability Test Phase	xxx,xxx.xx GB

techniques used (e.g., compression, deduplication)

10.8.5.2 Physical Space Utilization

If any of the [LOGICAL VOLUMES](#) reported in Logical Volume Addressable Capacity and ASU Mapping of clause 10.8.4.6 are space-optimized, then the [PHYSICAL FREE SPACE](#) available in the [TSC](#) shall be disclosed, as required by 5.2.3.2 and 6.3.8.4 . All three space utilization measurements should be reported in a single table, as illustrated in Table 10-7.

10.8.5.3 Space Optimization Reporting

If any of the [LOGICAL VOLUMES](#) reported in Table 10-8 of clause 10.6.2.5 are space-optimized, then the [SPACE OPTIMIZATION RATIO](#) and the [SPACE EFFECTIVENESS RATIO](#), as defined in clause 2.7.4, must reported in a table such as Table 10-8. The actual values of these ratios shall be truncated (rounded toward zero) to two decimal places for reporting purposes.

Table 10-9 Space Optimization Ratios

Space Optimization Ratio	
SPC-1 Space Optimization Ratio	n.nn
SPC-1 Space Effectiveness Ratio	n.nn

10.9 Benchmark Execution Results

10.9.1 Benchmark Execution Overview

The [FDR](#) must contain the following general information about the execution of the benchmark:

- The name of the file included in the SUPPORTING FILES and that contains the SPC-1 [WORKLOAD GENERATOR](#) input parameters for the PRIMARY METRICS [TEST PHASES](#), as produced by a supported version of the SPC-1 data reduction tool.
- The Measurement Intervals by [TEST PHASE](#) Graph of the average IOPS and the average Response Times measured over the MEASUREMENT INTERVALS of each [TEST PHASE](#)
- The Response Time vs. Throughput Graph of the average response time versus the IOPS for RAMPD_100 TO RAMPD_10.

10.9.2 ASU Pre-Fill

For the [ASU](#) pre-fill (see 5.2.3) the [FDR](#) must contain:

- The name of the file included in the SUPPORTING FILES and that contains the data resulting from the execution of the [ASU](#) pre-fill as produced by a supported version of the SPC-1 data reduction tool.
- The timing of the execution of the [ASU](#) pre-fill, including the start time, the end time, and the duration.
- The requested IOP level.
- The observed IOP level, calculated as the [ASU CAPACITY](#) populated during the [ASU](#) pre-fill divided by the duration of the [ASU](#) pre-fill, and reported as MB/second.

10.9.3 SUSTAIN Test Phase

For the SUSTAIN [TEST PHASE](#) the [FDR](#) must contain:

- The name of the file included in the SUPPORTING FILES and that contains the data resulting from the execution of the SUSTAIN [TEST PHASE](#), as produced by a supported version of the SPC-1 data reduction tool.
- The timing of the execution of the [TEST PHASE](#), including the [TRANSITION](#) period and the [MEASUREMENT INTERVAL](#).
- The Throughput Graph, as produced by a supported version of the SPC-1 data reduction tool.
- The Response Time Graph, as produced by a supported version of the SPC-1 data reduction tool.
- The Data Rate Graph, as produced by a supported version of the SPC-1 data reduction tool.
- The Response Time Frequency Graph, as produced by a supported version of the SPC-1 data reduction tool.
- The measured intensity multiplier for each [I/O STREAM](#), its coefficient of variation and the percentage of difference from the intensity multiplier defined for that [I/O STREAM](#).

10.9.4 RAMPD_100 Test Phase

For the RAMPD_100 [TEST PHASE](#) the [FDR](#) must contain:

- The name of the file included in the [SUPPORTING FILES](#) and that contains the data resulting from the execution of the RAMPD_100 [TEST PHASE](#), as produced by a supported version of the SPC-1 data reduction tool.
- The timing of the execution of the [TEST PHASE](#), including the [TRANSITION](#) period and the [MEASUREMENT INTERVAL](#).
- The Throughput Graph, as produced by a supported version of the SPC-1 data reduction tool.
- The Response Time Graph, as produced by a supported version of the SPC-1 data reduction tool
- The Data Rate Graph, as produced by a supported version of the SPC-1 data reduction tool.
- The Response Time Frequency Graph, as produced by a supported version of the SPC-1 data reduction tool
- The measured intensity multiplier for each [I/O STREAM](#), its coefficient of variation and the percentage of difference from the intensity multiplier defined for that [I/O STREAM](#).
- A summary of the [I/O REQUESTS](#) during the [MEASUREMENT INTERVAL](#), including the total number of completed [I/O REQUESTS](#), the number of [I/O REQUESTS](#) with a [RESPONSE TIME](#) less than or equal to 30.00 milliseconds and the number of [I/O REQUESTS](#) with a [RESPONSE TIME](#) greater than 30.00 milliseconds.

10.9.5 Response Time Ramp Test

For each [TEST PHASE](#) in the RESPONSE TIME RAMP Test, the [FDR](#) must contain:

- The name of the file included in the SUPPORTING FILES and that contains the data resulting from the execution of the [TEST PHASE](#)s from the Response Time Ramp Test, as produced by a supported version of the SPC-1 data reduction tool.
- The Average Throughput Graph from the [TEST PHASE](#)s of the Response Time Ramp Test, as produced by a supported version of the SPC-1 data reduction tool.

- The Average Response Time Graph from the [TEST PHASES](#) of the Response Time Ramp Test, as produced by a supported version of the SPC-1 data reduction tool.
- The Response Time Graph for the RAMPD_10 [TEST PHASE](#), as produced by a supported version of the SPC-1 data reduction tool.

10.9.6 Repeatability Test Phase Group

For each [TEST PHASE](#) in the Repeatability Test Phase Group the [FDR](#) must contain:

- The name of the file included in the [SUPPORTING FILES](#) and that contains the data resulting from the execution of the Repeatability [TEST PHASES](#), as produced by a

Table 10-10 Repeatability Test Results

Test Phase	100% IOPS	10% IOPS
RAMPD	n,nnn.nn	n.nn
REPEAT_1	n,nnn.nn	n.nn
REPEAT_2	n,nnn.nn	n.nn

- supported version of the SPC-1 data reduction tool.
- A table comparing the results of the RAMPD_100 and RAMPD_10 with the Repeatability Test results. The content, appearance, and format of the table are illustrated by example in Table 10-6 Repeatability Test Results.
- A Throughput Graph and a Response Time Graph for the REPEAT_1_100 [TEST PHASE](#), as produced by a supported version of the SPC-1 data reduction tool.
- A Throughput Graph and a Response Time Graph for the REPEAT_2_100 [TEST PHASE](#), as produced by a supported version of the SPC-1 data reduction tool.
- The measured intensity multiplier for each [I/O STREAM](#), its coefficient of variation and the percentage of difference from the intensity multiplier defined for that [I/O STREAM](#), reported for both Repeatability [TEST PHASES](#).

10.9.7 Data Persistence Test

For the PERSISTENCE TEST the [FDR](#) must contain:

- The name of the file included in the [SUPPORTING FILES](#) and that contains the data resulting from the execution of the PERSISTENCE [TEST](#), as produced by a supported version of the SPC-1 data reduction tool.

A table presenting key results from the PERSISTENCE [TEST](#). The content, appearance, and format of this table are illustrated by example in Table 10-8.

Table 10-11 Data Persistence Test Results

Data Persistence Test Phase: PersistN (1)	
Total Number of Logical Blocks Written (2)	XXX,XXX
Total Number of Logical Blocks Verified (3)	YYY,YYY
Total Number of Logical Blocks that Failed Verification (4)	ZZ
Time Duration for Writing Test Logical Blocks (sec.) (5)	SSS
Size in Bytes of each Logical Block (6)	ZZ,ZZZ,ZZZ
Number of Failed I/O Requests in the process of the Test (7)	R
Shutdown and power cycled Host System(s)? (8)	Yes/No

Footnotes to

Table 10-11 :

1. *The Test Number within the set of PERSISTENCE TEST executed to validate the Data Persistence Requirement. The Test Number shall be an integer value representing the position in a sequence beginning with the number one (1).*
2. *The total number of LOGICAL BLOCKs written during the Persist1 TEST PHASE.*
3. *The total number of LOGICAL BLOCKs that passed verification in during the Persist2 TEST PHASE of this Test.*
4. *The total number of LOGICAL BLOCKS that failed verification in during the Persist1 TEST PHASE of this Test.*
5. *Wall clock time in minutes and seconds required to complete the Persist1 TEST PHASE of this TEST.*
6. *The number of bytes per LOGICAL BLOCK in the TSC.*
7. *The number of FAILED I/O REQUESTS.*
8. *“Yes” if the HOST SYSTEM(S) were shutdown and power cycled, or “No” otherwise.*

10.10 Benchmark Extension Results

For each benchmark extension executed as part of the MEASUREMENT, the FDR shall contain:

- The name of the extension;
- The revision of the extension;
- All disclosures required by the benchmark extension.

Clause 11 Measurement, Audit, and Results Submission

11.1 Introduction

The SPC result validation process is intended to provide consumers with SPC-1 [RESULT](#) that are complete, accurate and reproducible. The SPC Result Validation process consists of:

- SPC-1 Audit (Clause 11.3).
- Measurement Submission (Clause 11.10)
- SPC Peer Review (Clause 11.11).

While it is not possible to preclude the possibility of an erroneous SPC-1 [RESULT](#), the SPC-1 Result Validation and SPC PEER REVIEW processes are designed to minimize the possibility that an SPC-1 [RESULT](#) could lead a consumer of that benchmark data to an erroneous or misleading conclusion about the [TESTED STORAGE PRODUCT](#) (Clause 4.5).

11.2 Types of new SPC-1 Results

11.2.1 New, Original SPC-1 Result

The creation of a new, original SPC-1 [RESULT](#) requires:

- Successful completion of the SPC result validation process, and
- Submission of all required materials to the SPC (Clause 11.10),

11.2.2 New SPC-1 Result based on an existing SPC-1 Result

An existing SPC-1 [RESULT](#) may be the basis of a new SPC-1 [RESULT](#) for a [TESTED STORAGE PRODUCT](#) other than the original [TESTED STORAGE PRODUCT](#) .

The creation of a new, SPC-1 [RESULT](#) of this type requires:

- Successful completion of an SPC-1 result validation process
- Submission of all required materials to the SPC (Clause 11.10),
- Derivative result requirements (Clause 11.12).

11.3 SPC-1 Audit

11.3.1 Overview

The purpose of the SPC-1 [AUDIT](#) is to verify a benchmark result is eligible for submission.

There are two types of SPC-1 [AUDIT](#) , onsite (Clause 11.6.1) and remote (11.6.2). Both require:

- Execution of the SPC-1 [AUDIT](#) procedures (11.6.3).
- Submission of a complete set of SPC-1 [RESULTS FILES](#) resulting from the execution of the complete set of SPC-1 [TESTS](#),
- Submission of an [FDR](#), and other required audit materials.

An SPC-1 [AUDIT](#) does not provide final certification that an SPC-1 [RESULT](#) is compliant with the specification. Certification that an SPC-1 [RESULT](#) is compliant with the specification is a function of the SPC Peer Review (Clause 11.11).

11.4 SPC-1 Audited Measurements

The execution of the complete set of SPC-1 Tests to create a complete set of SPC-1 [RESULTS FILES](#) , which will form the basis of an SPC-1 RESULT, is performed by the [TEST SPONSOR](#) in the course of either an Onsite or Remote SPC-1 [AUDIT](#) .

11.5 Auditor

11.5.1 An SPC-1 [AUDITOR](#) is an individual who has been certified by the SPC to perform an SPC-1 [AUDIT](#) .

11.5.2 The [AUDITOR](#) will, in the course of the SPC-1 AUDIT, determine if the benchmark result is eligible for submission to the SPC.

11.5.3 The SPC will provide a list of [AUDITORS](#) to the [TEST SPONSOR](#). The [TEST SPONSOR](#) is free to choose any [AUDITOR](#) from that list.

11.6 General Audit Procedures

11.6.1 SPC-1 On-Site Audit

11.6.1.1 To satisfy the SPC-1 audit requirements an SPC-1 [BENCHMARK](#) execution may require the on-site presence of an [AUDITOR](#). This is referred to as a SPC-1 ON-SITE [AUDIT](#) . The [AUDITOR](#) will determine when a SPC-1 ON-SITE AUDIT is required.

11.6.1.2 During an ON-SITE [AUDIT](#) , the [AUDITOR](#) is physically present at the site where the [TEST SPONSOR](#) has assembled the [BENCHMARK CONFIGURATION](#).

11.6.1.3 The [TEST SPONSOR](#) is responsible for the costs of an SPC-1 ON-SITE [AUDIT](#) .

11.6.2 SPC-1 Remote Audit

11.6.2.1 An SPC-1 [BENCHMARK](#) execution may satisfy SPC-1 audit requirements, without the on-site presence of an [AUDITOR](#), subject to the approval of an [AUDITOR](#). This is referred to as a SPC-1 REMOTE [AUDIT](#) .

11.6.2.2 Remote access to the [BC](#) can be optionally supplied by the [TEST SPONSOR](#) to facilitate the SPC-1 REMOTE [AUDIT](#) process.

11.6.3 General Rules

11.6.3.1 An independent audit of the benchmark [RESULT](#) by an [AUDITOR](#) is required.

11.6.3.2 The [AUDITOR](#)'s attestation letter is to be made readily available to the public as part of the FULL DISCLOSURE REPORT. A detailed report from the [AUDITOR](#) is not required.

11.6.4 New SPC-1 Result based on an Existing SPC-1 Result

11.6.4.1 If the new SPC-1 RESULT is based on an existing SPC-1 [RESULT](#)(i.e., a source SPC-1 [RESULT](#)), the following audit requirements apply to the new SPC-1 [RESULT](#):

- The [AUDITOR](#) must verify that the hardware and software components used in the [PRICED STORAGE CONFIGURATION](#) of the new SPC-1 RESULT are the same as those used in the source SPC-1 [RESULT](#), except for differences related to branding or packaging;

- The [AUDITOR](#) must compare the [FDR](#) of the new SPC-1 RESULT with the [FDR](#) of the SOURCE SPC-1 RESULT and ensures that differences are related to [TEST SPONSOR](#) identification, submission date, branding or packaging;
- The [AUDITOR](#) must review the validity of the pricing used for the new SPC-1 [RESULT](#).

11.6.4.2 In the event that all conditions listed in Clause 11.6.4.1 are met, the [AUDITOR](#) is not required to follow the clause specific audit procedures from Clause 11.7.

11.7 Clause Specific Audit Procedures

11.7.1 Clause 0 Related Items

Obtain a Letter of Good Faith from the [TEST SPONSOR](#) signed by an appropriate senior executive. The Letter of Good Faith is required to appear on company letterhead. The document must be identical in format and content to the template in Appendix A with the appropriate changes specific to the benchmark submission ([TEST SPONSOR](#) name, [TSC](#) name, date, etc.). Any other changes in content and format must be approved by the SPC Compliance Review Committee (CRC) prior to the benchmark submission.

11.7.2 Clause 1 Workload Environment Related Items

None

11.7.3 Clause 2 Storage Related Items

11.7.3.1 Verification Items

1. Verify the [PHYSICAL STORAGE CAPACITY](#) and requirements stated in 2.2.
2. Verify [LOGICAL VOLUME ADDRESSABLE CAPACITY](#) and requirements stated in 2.3.
3. Verify the [ASU CAPACITY](#) of each [APPLICATION STORAGE UNIT](#) and requirements stated in Clause 2.4.
4. Confirm whether or not space optimization was applied to any [APPLICATION STORAGE UNIT](#). If it was used, confirm that the summary description required by clause 10.8.4.6 is appropriate.

11.7.4 Clause 3 Workload and I/O Operation Profile Related Items

None

11.7.5 Clause 4 Benchmark Configuration & Tested Storage Configuration Related Items

11.7.5.1 Verification Items

1. Obtain a copy of [BENCHMARK CONFIGURATION](#) diagram ([BC/TSC](#) Configuration Diagram). If a storage network is employed in the [BC/TSC](#), obtain a copy of (Storage Network Configuration Diagram). Confirm the components illustrated in the two figures.
2. Obtain a listing of all customer tunable parameters and options that have been altered from their default values. The listing must contain the name of each component with an altered parameter/option, the name of the parameter/option, and the altered value. .
3. Obtain information that is sufficient to recreate the logical representation of the [TSC](#) (Clause 10.8.4.3). That information must include, at a minimum, a diagram and/or description of the following:

- All physical components that comprise the [TSC](#).
 - The logical representation of the [TSC](#) presented to the SPC-1 [WORKLOAD GENERATOR](#).
4. Verify the required configuration information for each [HOST SYSTEM](#) (Clause 10.7.4).
 5. Verify the presence and version number of each SPC-1 [WORKLOAD GENERATOR](#) on each [HOST SYSTEM](#) in the [BC](#).
 6. Verify the [TESTED STORAGE CONFIGURATION](#) boundary within each [HOST SYSTEM](#) of the [BC](#) as documented in Clause 4.4 and as illustrated in Figure 4-1 through Figure 4-5.
 7. In a multi-host configuration, verify compliance with Clause 5.2.11.
 8. In a multi-host configuration, verify that the execution of multiple SPC-1 [WORKLOAD GENERATORS](#) on multiple [HOST SYSTEMS](#) are synchronized in time and therefore support the requirements of Clause 5.2.11.

Comment: *Verification of items #6, #7 and #8 may be done using the appropriate SPC-1 RESULTS FILES.*

11.7.6 **Clause 5 SPC Test Methodology Related Items**

None.

11.7.7 **Clause 6 SPC-1 Measurement Requirements (Execution Rules) Related Items**

11.7.7.1 Remote Audit Related Items

1. Obtain SPC-1 [RESULTS FILES](#) for each Test.
2. Authenticate the SPC-1 [RESULTS FILES](#) obtained in #1.
3. Inspect each Summary [RESULTS FILES](#) to determine compliance with all the constraints and requirements of Clause 4, Clause 5, and Clause 6.

11.7.7.2 On-Site Audit Related Items

1. Observe the execution of each Test and determine compliance with the requirements and constraints of Clause 6.
2. Obtain SPC-1 [RESULTS FILES](#) for each Test.
3. Authenticate the SPC-1 [RESULTS FILES](#) obtained in #2.
4. Inspect each SPC-1 [RESULTS FILES](#) to determine compliance with all the constraints and requirements of Clause 4, Clause 5, and Clause 6.

11.7.8 **Clause 7 Data Persistence Requirements and Test Related Items**

11.7.8.1 General Validation and System Power Cycle

If the [TEST SPONSOR](#) did not shutdown and power cycle the [HOST SYSTEM\(s\)](#), based on Clause 7.4.3, the [AUDITOR](#) may require additional information to ensure the submitted PERSISTENCE TEST results are compliant. If, after reviewing all available information, compliance of the submitted PERSISTENCE [TEST](#) results remains in question, the [TEST SPONSOR](#) will be required to re-run the PERSISTENCE [TEST](#) and include the [HOST SYSTEM\(s\)](#) shutdown and power cycle step.

11.7.8.2 Remote Audit Related Items

1. Obtain the successful PERSISTENCE [TEST RESULTS FILES](#).

2. Authenticate the successful PERSISTENCE [TEST RESULTS FILES](#) obtained in #1.
3. Inspect the PERSISTENCE [TEST RESULTS FILES](#) to determine compliance or non-compliance with all the constraints and requirements of Clause 4, Clause 5, and Clause 6.

11.7.8.3 On-Site Audit Related Items

1. Observe the successful PERSISTENCE [TEST](#) and determine its compliance with the requirements and constraints of Clause 7.
2. Obtain the PERSISTENCE [TEST RESULTS FILES](#) from each TEST.
3. Authenticate the successful PERSISTENCE [TEST RESULTS FILES](#) obtained in #1.
4. Inspect the PERSISTENCE [TEST RESULTS FILES](#) to determine compliance or non-compliance with all the constraints and requirements of Clause 4, Clause 5, and Clause 6.
5. Optional: Observe all runs (success or failure) of the PERSISTENCE [TEST](#).

11.7.9 Clause 8 Reported Data Related Items

If the [TESTED STORAGE CONFIGURATION](#) and [PRICED STORAGE CONFIGURATION](#) are not identical, verify that the differences between the two configurations are disclosed and that the [PRICED STORAGE CONFIGURATION](#) would be capable of providing at least the same level of reported performance as the [TSC](#).

11.7.10 Clause 9 Pricing Related Items

For both on-site [AUDITS](#) and remote [AUDITS](#) ensure the [FDR](#) submitted is complete and accurate based on the requirements in Clause 9 and the *SPC Pricing Guide*.

11.8 SPC-1 Audit Certification

11.8.1 If the [AUDITOR](#) determines the benchmark result is eligible for submission, the [AUDITOR](#) will produce an SPC Audit Certification letter attesting to the successful completion of the SPC-1 Audit and issue that letter to the [TEST SPONSOR](#).

11.8.2 The SPC-1 Audit Certification letter will document execution of the SPC-1 Audit procedures defined in Clause 11.6.3. The SPC-1 Audit Certification letter for a successful SPC-1 Audit will contain any anomalous or inconsistent element encountered during the audit. While those elements did not prevent successful completion of the audit, their presence warranted documentation.

If the benchmark result is eligible for submission to the SPC, the [TEST SPONSOR](#) may then submit the required materials to the SPC to establish a new SPC-1 RESULT (Clause 11.10) and begin the SPC PEER REVIEW (Clause 11.11).

11.8.3 If the [AUDITOR](#) determines the benchmark result is not eligible for submission, the [TEST SPONSOR](#) may request an SPC-1 AUDIT REPORT that documents the compliance issues encountered during the SPC-1 AUDIT. In addition, the SPC-1 AUDIT REPORT will include recommendations to address the eligibility issues.

11.8.4 If the [TEST SPONSOR](#) disagrees with the [AUDITOR](#)'s determination of eligibility, the [TEST SPONSOR](#) may submit an appeal to the SPC Compliance Review Committee.

11.9 FDR Verification

This verification would include:

- The required FULL DISCLOSURE REPORT ([FDR](#)) is **complete** (Clause 10.5).
- Information contained in the [FDR](#) is **authentic**. For example, verify that SPC-1 RESULTS FILES produced by the SPC-1 [WORKLOAD GENERATOR](#) are unaltered and represent the actual execution of the SPC-1 [WORKLOAD GENERATOR](#).
- Information contained in the [FDR](#) is **accurate** and meets all of the requirements of this specification.

11.10 SPC-1 Measurement Submission

A [TEST SPONSOR](#) has the option to prepare a complete SPC-1 measurement submission based on a successful SPC-1 Audit. That submission, when received by the SPC, creates a new SPC-1 RESULT.

11.10.1 SPC-1 Measurement Submission Materials

A complete SPC-1 measurement submission consists of the following items submitted to the SPC by the [TEST SPONSOR](#):

- A PDF version of the audited SPC-1 [FULL DISCLOSURE REPORT \(FDR\)](#) and [EXECUTIVE SUMMARY](#)
- Payment to the SPC of all SPC-1 [AUDIT](#) costs and SPC-1 [RESULT](#) filing fee.
- A release, if not previously submitted, allowing public disclosure of the SPC-1 [RESULT](#) and [FDR](#).

11.10.2 New SPC-1 Result

When the SPC-1 measurement submission is successfully completed:

- A unique SPC-1 SUBMISSION IDENTIFIER is created for the submitted SPC-1 measurement.
- The submitted SPC-1 measurement becomes a new SPC-1 RESULT that is in “Submitted For Review” status.
- A copy of both SPC-1 [FULL DISCLOSURE REPORT](#) and [EXECUTIVE SUMMARY](#) are placed on the SPC website in the “Benchmark Results” section.
- A notification email is sent to the SPC membership announcing the new SPC-1 [RESULT](#).
- The SPC Peer Review begins (*Clause 11.11*).

11.10.3 SPC-1 Submission Identifier

An SPC-1 [SUBMISSION IDENTIFIER](#) takes the following format: **Annnnn-N**. Where:

Annnnn is a unique code assigned by the SPC that identifies an original SPC-1 RESULT and SPC-1 AUDIT.

N is the identifier for a republished SPC-1 result and Audit. The identifier will be omitted in the case of the original SPC-1 [RESULT](#) and SPC-1 AUDIT (SPC-1 [SUBMISSION IDENTIFIER](#)= Annnnn). The first reuse of a SPC-1 [SUBMISSION IDENTIFIER](#) will set the value of N to 1

(SPC-1 [SUBMISSION IDENTIFIER](#)= Annnnn-1). Each subsequent reuse will increment the value of N by 1.

11.11 SPC Peer Review

The SPC peer review of a new SPC [RESULT](#) begins when the result is created (*Clause 11.10.2*) and encompasses all the information contained in the SPC-1 FULL DISCLOSURE REPORT submitted for the result.

SPC PEER REVIEW of revisions to an existing SPC-1 [RESULT](#) begins when the revised SPC-1 FULL DISCLOSURE REPORT ([FDR](#)) is submitted to the SPC. The peer review, in this case, is limited to the revised information in the newly submitted [FDR](#), which includes any component changes in the PRICED STORAGE CONFIGURATION.

The SPC peer review is the final step to certify the SPC-1 [RESULT](#)'s compliance with this specification. Upon successful completion of the SPC peer review, a new SPC-1 [RESULT](#) transitions from a "Submitted for Review" status to an "Accepted" status. Details of the SPC peer review are described in the SPC Policies and Procedures (*Section 9.1,c*).

11.12 Creating a new SPC-1 Result based on an existing SPC-1 Result

11.12.1 General Requirements

An existing SPC-1 [RESULT](#) may be the basis of a submission to create a new SPC-1 [RESULT](#) if the following requirements are met:

- The [TESTED STORAGE PRODUCT](#) for the new SPC-1 RESULT is not the same as the [TSP](#) in the existing SPC-1 [RESULT](#).
- Any hardware and/or software differences between the existing and new [PRICED STORAGE CONFIGURATIONS](#) do not impact the performance-related [PRIMARY METRICS](#) and [SECONDARY METRICS](#).
- All performance data disclosed in the new SPC-1 [FDR](#) is identical to that which is contained in the original [FDR](#).
- The existing SPC-1 [RESULT](#) is either in "Submitted for Review" or "Accepted" status.
- The requirements for results re-use defined in the *SPC Pricing Guide* are satisfied.

The intent of this clause is to allow a reseller of equipment from a given supplier to publish a result naming their particular brand or model number without requiring any additional performance testing.

11.12.2 Withdrawal of the existing SPC-1 Result

If an SPC-1 [RESULT](#) successfully completes peer review and is subsequently withdrawn with no compliance issue outstanding, SPC-1 [RESULTS](#) based on the withdrawn SPC-1 [RESULT](#) are not required to be withdrawn.

11.13 SPC-1 Result Revisions

11.13.1 Valid Revisions

Revisions to an existing SPC-1 RESULT can occur only under the following conditions:

- Fully documented pricing changes to the [PRICED STORAGE CONFIGURATION](#) (see *SPC Pricing Guide*).

- A change in the SPC-1 [AVAILABILITY DATE](#) (see *SPC Pricing Guide*).
- As directed by the SPC Policies.

In all cases, the resulting revised SPC-1 [FULL DISCLOSURE REPORT](#) is required to be reviewed and approved by an [AUDITOR](#) prior to submission to the SPC (*Clause 11.10*).

11.13.2 SPC Policies Directed Revisions

Revisions to an SPC-1 [RESULT](#) may result from provisions in the SPC Policies and Procedures such as in the case of a compliance issue identified during the SPC peer review.

11.13.3 Component Substitution in a revised SPC-1 Result

If a revision to an existing SPC-1 [RESULT](#) would result in a change to the [PRICED STORAGE CONFIGURATION](#) documented in the corresponding SPC-1 [FDR](#), the [TEST SPONSOR](#) must submit, for review by an [AUDITOR](#), a list of components that would be changed. The [AUDITOR](#) may require additional information and/or specific tests to be executed to ensure the revised [PRICED STORAGE CONFIGURATION](#) is capable of successfully completing the PERSISTENCE [TEST](#), as well as, providing at least the same level of reported performance as stated in the current [FDR](#).

Examples of component substitutions include:

- Replacement of a now obsolete component that was included in the existing [PRICED STORAGE CONFIGURATION](#) .
- Replacement of a component when a change in the component's availability would extend the SPC-1 [AVAILABILITY DATE](#) beyond the period allowed by the specification.

If the [PRICED STORAGE CONFIGURATION](#) component changes are approved by the [AUDITOR](#), an amended SPC-1 Audit Certification letter will be issued to the [TEST SPONSOR](#) for inclusion in a revised [FDR](#), which will contain a list of all changes (*Clause 10.8.2.1*). If the [AUDITOR](#) does not approve the component changes, the [TEST SPONSOR](#) may appeal that decision to the SPC Compliance Review Committee.

Appendix A Letter of Good Faith Template

The required Letter of Good Faith submitted by a [TEST SPONSOR](#) must be identical in format and content to the template listed below with the appropriate changes specific to the benchmark submission ([TEST SPONSOR](#) name, [TSC](#) name, date, etc.). Any other changes in content or format must be approved by the [AUDITOR](#) prior to the benchmark submission.

Date: Date the benchmark result is submitted to the [AUDITOR](#)

From: Test Sponsor Name and Contact Information

To: Auditor Name and Contact Information

Subject: SPC-1 Letter of Good Faith for the *Tested Storage Configuration name*

Test Sponsor Name is the SPC-1 Test Sponsor for the above listed product. To the best of our knowledge and belief, the required SPC-1 benchmark results and materials we have submitted for that product are complete, accurate, and in full compliance with ***Vn.n*** of the SPC-1 benchmark specification.

In addition, we have reported any items in the Benchmark Configuration and execution of the benchmark that affected the reported results even if the items are not explicitly required to be disclosed by the SPC-1 benchmark specification.

Signed:

Date:

Name and title of an appropriate
Test Sponsor senior executive

Date of Signature

Appendix B The Hierarchical Reuse Random Walk

This appendix describes the “hierarchical reuse” random walk, which is employed in the specifications of the two random access patterns R1 and W1. Readers desiring a more in-depth treatment of this subject are also referred to Chapter 2 of *The Fractal Structure of Data Reference: Applications to the Memory Hierarchy*, by Bruce McNutt (ISBN 0-7923-7945-4, available from Kluwer Academic Publishers).

The objective of the hierarchical reuse random walk is to produce a pattern of requests in which the probability of data reuse is inversely proportional to the time since the first use. This characteristic, which matches well with real-world data reference behavior, reflects a specific form of self-similarity in the distribution of re-use events.

The hierarchical reuse random walk is performed within the leaves of a symmetric binary tree. Each leaf (each storage location) is assigned a leaf number $0 \leq l \leq 2^{Hmax}$. The tree structure makes it possible to emulate the desired self-similar distribution of re-use events.

Starting from a given leaf l_i of the tree, the next leaf l_{i+1} is determined as follows. First, climb a number of nodes $0 \leq k \ll Hmax$ above leaf l_i . Then, with probability v climb one node higher; with another probability of v climb an additional node higher; and so on (but stop at the top of the tree). Finally, select a leaf at random from all of those belonging to the sub-tree under the current node.

No special data structure is needed to implement the random tree-climbing operation just described. Instead, it is only necessary to calculate the random height $0 \leq H \leq Hmax$ at which climbing terminates. The next leaf is then given by the formula:

$$l_{i+1} = 2^H [l_i / 2^H] + [2^H R]$$

where R is a uniformly distributed random number in the range $0 \leq R < 1$, and where the brackets ([]) indicate truncation to an integer.

Appendix C Glossary

The SPC Glossary is used in all SPC specifications, and is available as a stand-alone document. It is included here in its entirety for ease of reference.

The following content is from *SPC Glossary, version 1.1*, which was current as of 16 July 2020

C.1 A

ADDRESSABLE CAPACITY

the portion of the storage capacity of a [LOGICAL VOLUME](#) that is accessible to the [WORKLOAD GENERATOR](#).

APPLICATION STORAGE UNIT (ASU)

the logical representation of the persistent, non-volatile storage read and or written in the course of executing a [BENCHMARK](#).

An ASU represents is a logical interface between a [BENCHMARK CONFIGURATION](#)'s data and a workload generator.

APPLICATION STORAGE UNIT CAPACITY

the total [ADDRESSABLE CAPACITY](#) of all the portions of [LOGICAL VOLUMES](#) to which an [ASU](#) is mapped.

APPLICATION STORAGE UNIT STREAM

a collection of one or more [I/O STREAMS](#), that completely defines the I/O sent to a given [ASU](#).

ASSOCIATED DATA

data and measurements defined by a given [BENCHMARK](#) that are used to calculate, clarify or reinforce the metrics reported as part of a [RESULT](#).

ASU

see [APPLICATION STORAGE UNIT](#).

ASU CAPACITY

see [APPLICATION STORAGE UNIT CAPACITY](#).

ASU PRICE

the ratio of [TOTAL SYSTEM PRICE](#) to [ASU CAPACITY](#).

ASU STREAM

see [APPLICATION STORAGE UNIT STREAM](#).

AUDIT

the process that verifies that a [MEASUREMENT](#) is eligible for submission as a [RESULT](#).

AUDITOR

An individual who has been certified by the SPC to perform an [AUDIT](#).

AVAILABILITY DATE

a date by which a given product, component or configuration is released for general availability.

AVERAGE RESPONSE TIME

the sum of the [RESPONSE TIMES](#) for all [MEASURED I/O REQUESTS](#) within a given interval, divided by the total number of [MEASURED I/O REQUESTS](#).

C.2

B

BC see [BENCHMARK CONFIGURATION](#).

BENCHMARK a collection of [TESTS](#), [TEST PHASES](#), documentation requirements, and comparability constraints that fully define the process for taking a [MEASUREMENT](#) and creating a [RESULT](#).

BENCHMARK CONFIGURATION

all hardware and software components used in the creation of a [MEASUREMENT](#).

C.3

C

COMPLETED I/O REQUEST an [I/O REQUEST](#) with a [START TIME](#) and a [COMPLETION TIME](#).

COMPLETION TIME

the time recorded by the [WORKLOAD GENERATOR](#) when an [I/O REQUEST](#) is satisfied by the [TSC](#).

COMMITTED Of an IO operation, written to persistent, non-volatile storage, in such a manner that the data can be retrieved after recovery from a [TSC](#) failure.

CONCURRENT IO REQUESTS

the maximum number of independent, concurrent [IO REQUESTS](#) that may be initiated by an [IO STREAM](#).

CRASH-CONSISTENT

A data image (logical or physical) is considered crash consistent if there exists a point in time such that all write operations completed prior to that time are included in the image, and no write operation initiated after that time is included.

C.4

D

DATA RATE the data volume transferred in a given interval divided by the duration of the interval, in seconds.

C.5

E

EXTENSION optional addition(s) to an existing [BENCHMARK](#) that showcase a feature or set of features not captured by the [BENCHMARK'S](#) existing metrics.

EXTENSION CONFIGURATION

all hardware and software components used in the execution of an [EXTENSION](#).

EXPECTED I/O COUNT

for any given [I/O STREAM](#) and [TEST PHASE](#), the product of requested IO load in IOs per second, the duration of the [TEST PHASE](#) in seconds, and the [INTENSITY MULTIPLIER](#) parameter for that [I/O STREAM](#).

EXECUTIVE SUMMARY

a high-level report summarizing a [RESULT](#), and the configuration used to produce it.

C.6**F****FAILED I/O REQUEST**

any [I/O REQUEST](#) issued by the [WORKLOAD GENERATOR](#) that could not be completed or was signaled as failed by the OS running on the [HOST SYSTEM](#).

A FAILED I/O request has no [COMPLETION TIME](#).

FDR

see [FULL DISCLOSURE REPORT](#).

FULL DISCLOSURE REPORT

a report detailing a [RESULT](#), along with the procedures, configuration, and equipment used to produce it.

C.7**G**

No terms defined.

C.8**H****HOST SYSTEM**

a computer system where the [WORKLOAD GENERATOR](#) executes.

C.9**I****IN-FLIGHT I/O REQUEST**

an [I/O REQUEST](#) issued by the [WORKLOAD GENERATOR](#) that does not complete within a given [MEASUREMENT INTERVAL](#).

INTEGRATED EXECUTION

of a benchmark extension: completed during one of the test phases of a benchmark execution.

INTENSITY MULTIPLIER

the ratio of the IO load produced by a given [I/O STREAM](#) to the total IO load produced by all active [I/O STREAMS](#).

I/O COMMAND

see [I/O REQUEST](#).

I/O STREAM

a single, well-defined, sequence of [I/O REQUESTS](#).

- i. **i/o request** a single, atomic I/O operation.

I/O REQUEST THROUGHPUT

the total number of [MEASURED I/O REQUESTS](#) in a [TEST PHASE](#), divided by the duration of that [TEST PHASE](#)'s [MEASUREMENT INTERVAL](#), expressed in seconds.

C.10**J**

No terms defined.

C.11**K**

No terms defined.

C.12**L**

LOGICAL BLOCK the smallest directly addressable unit of storage on the [ASU](#).

LOGICAL VOLUME *an individually addressable logical unit of storage presented to the [WORKLOAD GENERATOR](#).*

C.13 **M**

MEASURED I/O REQUEST
an [I/O REQUEST](#) with a [COMPLETION TIME](#) occurring within the [MEASUREMENT INTERVAL](#).

MEASURED INTENSITY MULTIPLIER
the percentage of all [MEASURED I/O REQUESTS](#) that were issued by a given [I/O STREAM](#).

MEASUREMENT *the data gathered during the execution of a [BENCHMARK](#).*

MEASUREMENT BOUNDARY
of the point within a [BENCHMARK CONFIGURATION](#) at which measurements are taken.

MEASUREMENT INTERVAL
of a [TEST PHASE](#), the time from the end of the [TRANSITION](#) to the start of the [RUNOUT](#).

C.14 **N**

No terms defined.

C.15 **O**

ON-SITE AUDIT *an [AUDIT](#) for which the [AUDITOR](#) is physically present.*

C.16 **P**

PHYSICAL CAPACITY UTILIZATION
[ASU CAPACITY](#) divided by the [PHYSICAL STORAGE CAPACITY](#).

PHYSICAL FREE SPACE
the persistent storage capacity that could be used to hold application data and the metadata required to access, maintain and protect that data, but is not in use at the time of the measurement.

PHYSICAL STORAGE CAPACITY
the total storage capacity of all of the [STORAGE DEVICES](#) in the [TESTED STORAGE CONFIGURATION](#).

PRICED DISCLOSURE ITEM
a pricing-related data item that is included in the [FDR](#), and is subject to requirements defined in the SPC Pricing Guide.

PRICED STORAGE CONFIGURATION (“PSC”)
the customer-orderable version of the [TSC](#).

PRICE-PERFORMANCE
the ratio of the [TOTAL SYSTEM PRICE](#) to the primary performance metric for a [BENCHMARK](#)”).

PRICING SPREADSHEET

a detailed computation of the total cost of ownership for a [PRICED STORAGE CONFIGURATION](#).

PRIMARY METRIC a metric that provides a primary basis for comparison of [RESULTS](#).

PROTECTED 1 a data protection level in which the failure of any single [STORAGE DEVICE](#) in the [TSC](#) will not require user intervention to restore access to the [BENCHMARK'S](#)) data repository.

PROTECTED 2 a data protection level in which the failure of any single component in the [TSC](#) will not require user intervention to restore access to the [BENCHMARK'S](#) data repository.

PSC see [PRICED STORAGE CONFIGURATION](#).

C.17

Q

No terms defined

C.18

R

RAMP-DOWN A specified, contiguous period of time in which the [TSC](#) is required to complete [I/O REQUESTS](#) started but not completed during the preceding [RUNOUT](#) period.

RAMP-UP A specified, contiguous period of time required for the [BC](#) to produce [STEADY STATE](#) throughput after the [WORKLOAD GENERATOR](#) begins submitting [I/O REQUESTS](#) to the [TSC](#) for execution.

REFERENCE PRICE

the price at which component or subsystem could be ordered individually from the [TEST SPONSOR](#) or designated third-party supplier.

REMOTE AUDIT an [AUDIT](#) for which the [AUDITOR](#) is not physically present. See [ON-SITE AUDIT](#).

REPLICATION the automatic execution of all I/O operations executed against a primary storage system on a one or more, independent storage systems.

REPORTED DATA The set of data, as defined by a given [BENCHMARK](#), which fully characterizes a [MEASUREMENT](#).

RESPONSE TIME for an [I/O REQUEST](#), [COMPLETION TIME](#) minus [START TIME](#).

RESULT an audited [MEASUREMENT](#) which has been submitted to the SPC for publication

RESULTS FILES the output of the [WORKLOAD GENERATOR](#), created during a [MEASUREMENT](#).

RUNOUT of a [TEST PHASE](#), the time period immediately following the [MEASUREMENT INTERVAL](#) during which the IO load presented by the [WORKLOAD GENERATOR](#) to the [TSC](#) remains constant long enough for any IO issued during the [MEASUREMENT INTERVAL](#) to complete.

C.19

S

SECONDARY METRIC a metric that is not a primary basis for comparison of [RESULTS](#), but still provides important information.

SER	see SPACE EFFECTIVENESS RATIO .
SOR	see SPACE OPTIMIZATION RATIO .
SNAPSHOT	a logical, point-in-time, CRASH-CONSISTENT image of one or more LOGICAL VOLUMES .
SNAPSHOT SET	a crash-consistent collection of SNAPSHOTS , taken and managed as a unit.
SPACE EFFECTIVENESS RATIO (“SER”)	the ratio of the total amount of data that the TSC can hold to its PHYSICAL CAPACITY .
SPACE OPTIMIZATION RATIO (“SOR”)	the size of a data set as generated by the WORKLOAD GENERATOR divided by the amount of incremental space consumed by that data set.
SPC RESULT	see RESULT .
SSU	see STIMULUS SCALING UNIT .
START TIME	for an I/O REQUEST , the time recorded by the WORKLOAD GENERATOR when the request is submitted for execution on the TSC .
STEADY STATE	a state in which the behavior of the TSC is stable and sustainable while the load presented to the TSC by the WORKLOAD GENERATOR is constant.
STIMULUS SCALING UNIT	a logical abstraction that captures the key elements in the IO demands of an application’s user population.
STORAGE DEVICE	a discrete, physical hardware component, such as an HDD or an SSD, that provides permanent data storage. A STORAGE DEVICE must be capable of storing data indefinitely without external power. The requirement excludes components that provide volatile data storage, such as a read and/or write cache.
STREAM	A collection of STREAM SEGMENTS .
STREAM SEGMENT	A sequentially organized pattern of I/O requests, which transfers a contiguous range of data.
SYNCHRONOUS REPLICATION	REPLICATION IN WHICH THE INITIAL I/O OPERATION IS NOT MARKED AS COMPLETE UNTIL THE RELATED OPERATION HAS COMPLETED ON THE OTHER, INDEPENDENT STORAGE SYSTEM(S).
SUBMISSION IDENTIFIER	a unique identifier, assigned by the SPC, for each new RESULT .

SUPPORTING FILES

a collection of data, documentation, and illustrations used to demonstrate the validity of a [RESULT](#).

C.20 **T**

TARGET COUNTRY

the country in which the [PRICED STORAGE CONFIGURATION](#) is available for sale no later than the [AVAILABILITY DATE](#), and in which the required hardware maintenance and software support is provided either directly from the [TEST SPONSOR](#) or indirectly via a third-party supplier

TEST

a collection of one or more [TEST PHASES](#) sharing a common objective.

TEST PHASE

the smallest logical component of a [TEST](#), during which a data is collected to satisfy the requirements of a [BENCHMARK](#).

TEST SPONSOR

a distinctly identifiable entity that acts as the sponsor of an [RESULT](#).

TESTED STORAGE CONFIGURATION

all software and hardware necessary to implement and support the storage configuration defined for a [MEASUREMENT](#).

TESTED STORAGE PRODUCT

a distinct, customer orderable product, which is the focal point of a [RESULT](#).

TOTAL SYSTEM PRICE

the total cost of ownership for the [PRICED STORAGE CONFIGURATION](#).

TRANSITION

of a [TEST PHASE](#), a time period during which the IO load presented by the [WORKLOAD GENERATOR](#) to the [TSC](#) is changing, either increasing or decreasing.

TSC

see [TESTED STORAGE CONFIGURATION](#).

TSC BOUNDARY

the boundary between the [HOST SYSTEM](#) and [TSC](#).

TSC EXECUTIVE

the software component of the [TSC](#).

TSP

see [TESTED STORAGE PRODUCT](#).

C.21 **U**

No terms defined.

C.22 **V**

No terms defined.

C.23 **W**

WORKLOAD

a collection of [ASU STREAMS](#).

WORKLOAD GENERATOR

a user-space application, provided by the SPC, that produces benchmark-specific [IO STREAMS](#).

C.24 **X**

No terms defined.

C.25 **Y**

No terms defined.

C.26 **Z**

No terms defined

Appendix D Sample Executive Summary

Two sample executive summaries are included. One with a single extension in addition to the base result publication, and one from a GoldStar result, which includes 5 extensions.



SPC Benchmark 1™ Executive Summary

SampleCo SC-1

SPC-1 IOPS™	10,001,522	SPC-1 Price Performance	\$644.16/SPC-1 KIOPS™
SPC-1 IOPS Response Time	0.418 ms	SPC-1 Total System Price	\$6,442,522.88
SPC-1 Overall Response Time	0.249 ms	SPC-1 Overall Discount	73.92%

Currency / Target Country	USD / USA
Availability Date	March 23, 2019

Extensions

★ SPC-1 Data Reduction	1.42 SER
☆ SPC-1 Encryption	NA
☆ SPC-1 NDU	NA
☆ SPC-1 Synchronous Replication	NA
☆ SPC-1 Snapshot	NA

Storage Metrics

SPC-1 Data Protection Level	Protected 2
SPC-1 Physical Storage Capacity	230,400 GB
SPC-1 ASU Capacity	90,452 GB
SPC-1 ASU Price	\$71.23/GB

Priced Storage Configuration Summary

- 88 PFC EP LPe HBAs (mixed models)
- 1 DS8900 S4
- 12 Controllers (2 Controller Modules each)
- 18,432 GB Total Cache
- 192 Total Front-End Ports
- 576 Total Storage Devices (SSDs)
- 4 Brocade Switches (mixed models)
- ## Total RUs

RAMPD Average Response Time (ms) vs. IOPS

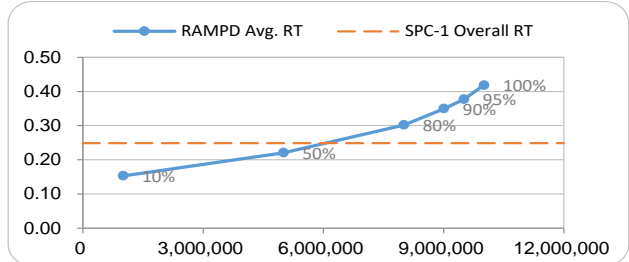

SUSTAIN Response Time (ms)

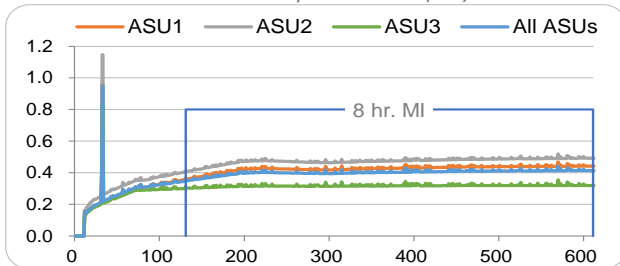

RAMPD_100 Response Time (ms)

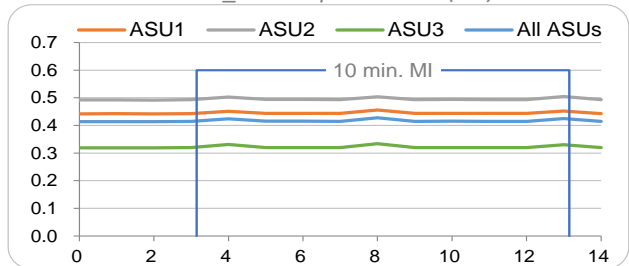

SPC Benchmark 1™ Specification Revision	3.8.0	Submission Identifier	A99999
SPC Benchmark 1™ Workload Generator Revision	3.0.2-1	Submitted for Review	March 23, 2019

For complete details, please visit: www.storageperformance.org/r/A99999

SPC-1, SPC-1 IOPS, SPC-1 KIOPS, SPC-1 Price Performance, SPC Benchmark 1, and the SPC Logo are trademarks of the Storage Performance Council.

SampleCo SC-1

SPC-1 IOPS™ **10,001,522**
 SPC-1 IOPS Response Time **0.418 ms**
 SPC-1 Overall Response Time 0.249 ms

SPC-1 Price Performance **\$644.16/SPC-1 KIOPS™**
 SPC-1 Total System Price **\$6,442,522.88**
 SPC-1 Overall Discount 73.92%

SPC-1 GoldStar Result

Currency / Target Country USD / USA
 Availability Date March 23, 2019

Extensions

- ★ SPC-1 Data Reduction 1.42 SER
- ★ SPC-1 Encryption Enabled
- ★ SPC-1 NDU Capable
- ★ SPC-1 Synchronous Replication Enabled
- ★ SPC-1 Snapshot Enabled

Storage Metrics

- SPC-1 Data Protection Level Protected 2
- SPC-1 Physical Storage Capacity 230,400 GB
- SPC-1 ASU Capacity 90,452 GB
- SPC-1 ASU Price \$71.23/GB

Priced Storage Configuration Summary

- 88 PFC EP LPe HBAs (mixed models)
- 1 DS8900 S4
- 12 Controllers (2 Controller Modules each)
- 18,432 GB Total Cache
- 192 Total Front-End Ports
- 576 Total Storage Devices (SSDs)
- 4 Brocade Switches (mixed models)
- ## Total RUs

RAMPD Average Response Time (ms) vs. IOPS

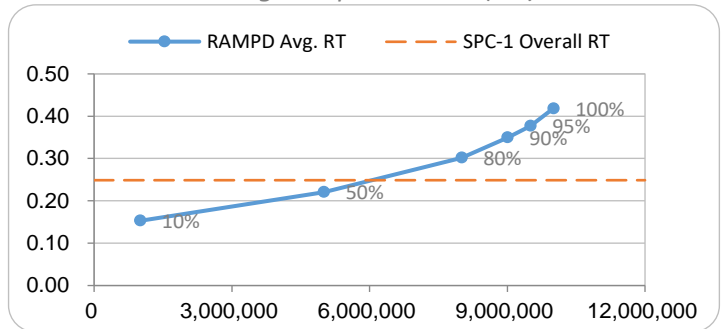

SUSTAIN Response Time (ms)

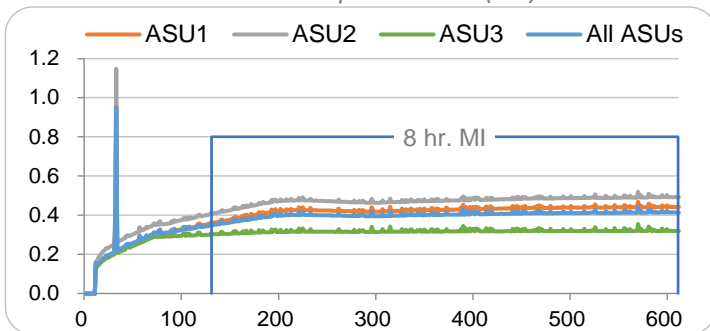

RAMPD_100 Response Time (ms)

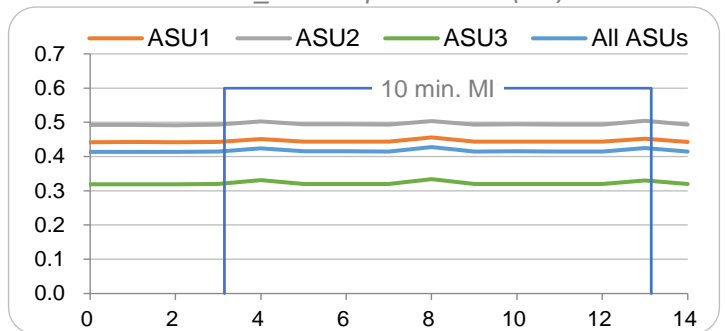

SPC Benchmark 1™ Specification Revision 3.8.0
 SPC Benchmark 1™ Workload Generator Revision 3.0.2-1

Submission Identifier A99999
 Submitted for Review March 23, 2019

For complete details, please visit: www.storageperformance.org/r/A99999

SPC-1, SPC-1 IOPS, SPC-1 KIOPS, SPC-1 Price Performance, SPC Benchmark 1, and the SPC Logo are trademarks of the Storage Performance Council.

Index

<hr/> A	
Adaptive Data Migration	42
Addressable Capacity	88
Application Storage Unit	12, 13, 15, 16, 18, 19, 21, 22, 24, 25, 29, 31, 32, 34, 36, 37, 38, 39, 41, 42, 43, 44, 45, 47, 51, 52, 71, 72, 74, 88, 90
Content	18
Pre-fill	18, 41, 42, 45, 47, 74
Space Optimization	19
Application Storage Unit Capacity	88
Application Storage Unit Stream	88
Associated Data	88
asu	See Application Storage Unit
ASU	41, 51, <i>See Application Storage Unit</i>
ASU Capacity	15, 19, 32, 33, 52, 55, 80, 88, 91, see Application Storage Unit Capacity
ASU Price	88
ASU stream	88
ASU Stream	21, 31, 32, 33, 94
Audit	10, 35, 36, 47, 78, 79, 80, 81, 82, 83, 85, 88, 91, 92
On-Site	79, 82
Remote	79
Audit Certification	47, 82
Audit Report	82
Auditor	42, 47, 52, 56, 61, 63, 64, 79, 81, 82, 85, 86, 88, 91, 92
Availability Date	85, 88, 94
<hr/> B	
Average Response Time	49, 50, 51, 55, 62, 88
BC	see Benchmark Configuration
Benchmark	88, 89, 91, 92, 94
Benchmark Configuration	34, 35, 36, 42, 43, 44, 47, 48, 49, 52, 67, 68, 69, 70, 71, 79, 80, 81, 88, 89
Benchmark Special	9
<hr/> C	
Completed I/O Request	89
Completion Time	45, 89, 90, 91, 92
<hr/> D	
Data Content	18
Data Protection	20, 56
Data Protection Level	20, 56
Data Rate	89
Data Repository	20
Data Re-reference	27
<hr/> E	
Executive Summary	83, 89
Expected I/O Count	89
Extension	89
<hr/> F	
Failed I/O Request	42, 77, 90
FDR	90, <i>See Full Disclosure Report</i>

Full Disclosure Report 47, 59, 61, 63, 70, 71, 76, 78, 79, 80, 83, 84, 85, 90

Measurement Interval 40, 41, 42, 43, 49, 50, 90, 91, 92

H

Host System 34, 35, 36, 37, 38, 42, 43, 44, 45, 47, 52, 53, 90, 94

I

I/O Command *See I/O Request, See I/O Request*

I/O Request 21, 22, 26, 29, 31, 32, 33, 42, 45, 51, 75, 89, 90, 91, 92, 93

I/O Request Throughput 49, 50, 51, 54, **90**

I/O Stream 21, 26, 27, 28, 29, 30, 31, 32, 43, 49, 75, 76, 88, 89, 90, 91

In-Flight I/O Request **90**

Intensity Multiplier 89, 90

IO Stream 94

L

Letter of Good Faith 9, 61, 80, 86

Log 14, 15, 16, 19, 34, 41, 44, 51, 52, 71, 72, 73, 74, 80

Logical Block 15, 22, 30, 77, **90**

Logical Volume 15, 34, 52, 88

Logical Volume Capacity 14, 80

Logical Volumes 16, 19, 41, 51, 71, 72, 73, 93

M

Measured I/O Request 43, 88, 90, **91**

Measured I/O Requests 91

Measured Intensity Multiplier 43, 49, **91**

Measurement 88, 89, **91**, 92, 94

Measurement Boundary 45

O

On-Site Audit **91**

P

Persistence Test 45

Physical Capacity 93

Physical Capacity Utilization 20, 72, **91**

Physical Free Space 16, 18, 19, 41, 51, 73, **91**

Physical Storage Capacity 14, 56, 80, 91

Priced Storage Configuration 61, 67, 82, 84, 85, **91**, 92, 94

Price-Performance **91**

Pricing 80

Pricing Spreadsheet **92**

Primary Metrics **92**

Primary Metrics 84

Primary Metrics Test 47, 48, 50

Protected 1 **92**

Protected 2 **89, 92**

PSC *see Priced Storage Configuration, see Priced Configuration*

R

Reference Price **92**

Remote Audit **92**

Reported Data 57, **92**

Response Time 88, **92**

Result 88, 89, 90, 92, 93, 94

Results Files	41, 92	SPC-1 IOPS	49, 50, 51, 52, 54
Runout	40, 42, 91, 92	SPC-1 Price-Performance	54, 57
<hr/>		SPC-1 Reported Data	54
S		SPC-1 Result	56, 57, 61, 62, 63, 64, 78, 79, 80, 82, 83, 84, 85
Secondary Metrics	55	SPC-1 Results Files	78, 79, 81, 83
SPC-1 Average Ramp Response Time	55	SPC-1 Secondary Metric	
SPC-1 IOPS™ Response Time	55	ASU Price	56
SER	see Space Effectiveness Ratio, see Space Optimization Ratio	SPC-1 Secondary Metrics	54
Snapshot	93	ASU Price	55
Space Effectiveness Ratio	55, 93	SPC-1 IOPS™ Response Time	55
Space Optimization		SPC-1 Submission Identifier	56, 61, 62, 83, 84
Space Optimization Ratio	19	SPC-1 Workload Generator	14, 15, 22, 26, 37, 38, 39, 40, 41, 42, 43, 45, 49, 52, 53, 71, 81, 83
Space Optimization		SSU	See Stimulus Scaling Unit, see Stimulus Scaling Unit
Space Effectiveness Ratio	19	Start Time	45, 89, 92, 93
Space Optimization Ratio	19	Steady State	40, 48, 93
Space Optimization	19	Stimulus Scaling Unit	12, 27, 93
Space Optimization Ratio	93	Storage Device	14, 36, 37, 38, 39, 42, 65, 66, 67, 91, 92, 93
Space Optmization		Submission Identifier	64, 93
Space Effectiveness Ratio	19	Support Files	94
SPC Auditor	79	<hr/>	
SPC Peer Review	78, 82, 84, 85	T	
SPC-1 Associated Data	54, 56	Target Country	57, 94
SPC-1 Audit	59	Test	40, 42, 47, 50, 89, 94
SPC-1 Benchmark	61, 79	Test Phase	40, 41, 42, 43, 47, 48, 49, 50, 51, 52, 53, 54, 55, 62, 89, 90, 91, 92, 94
SPC-1 Primary Metric		Test Sponsor	9, 10, 13, 20, 34, 35, 36, 41, 42, 44, 47, 48, 49, 52, 53, 59, 61, 62, 63, 64, 65, 70, 79, 80, 81, 82, 83, 85, 86, 92, 94
SPC-1 Price-Performance	54		
SPC-1 Primary Metrics	54		
SPC-1 Average Ramp Response Time	55, 62		

Tested Storage Configuration	19, 20, 34, 35, 36, 37, 38, 40, 41, 42, 44, 47, 48, 49, 50, 51, 52, 53, 54, 58, 59, 61, 64, 65, 66, 67, 71, 77, 80, 81, 82, 86, 89, 91, 92, 93, 94
Tested Storage Product	39, 56, 61, 62, 65, 78, 84, 94
Total System Price	54, 57, 88, 91, 94
Transition	40, 41, 42, 48, 53, 91, 94
TSC	16, 19, 41, 51, 73, 93, see Tested Storage Configuration
TSC Boundary	94
TSP	see Tested Storage Product

W

Workload	21, 22, 26, 27, 29, 31, 41, 43, 94
Workload Generator	88, 89, 90, 92, 93, 94
Workload Generator	88
Workload Generator	90
Workload Generator	91
Workload Generator	92
Workload Generator	93
Workload Generator	94